



941071-00

Electric Power Transfer (EPT)

EPT2, EPT10, & EPT10C

VON DUPRIN®

Installation Instructions

Tools for Install

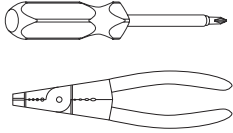

Read all Warnings Before Starting Installation!

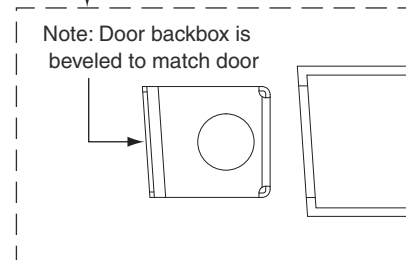
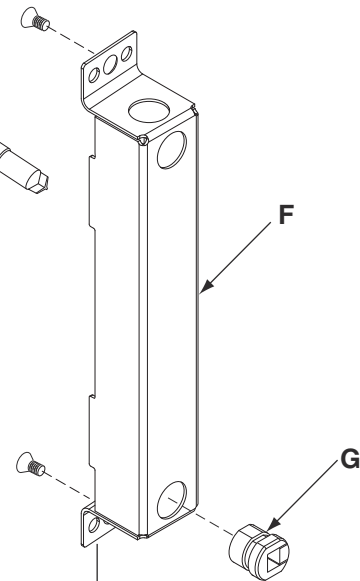
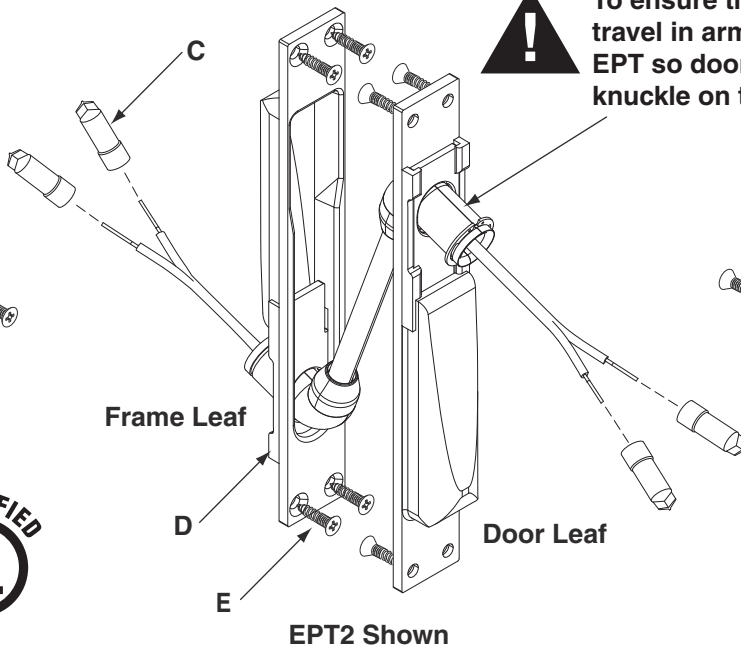
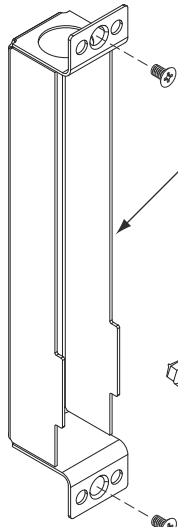
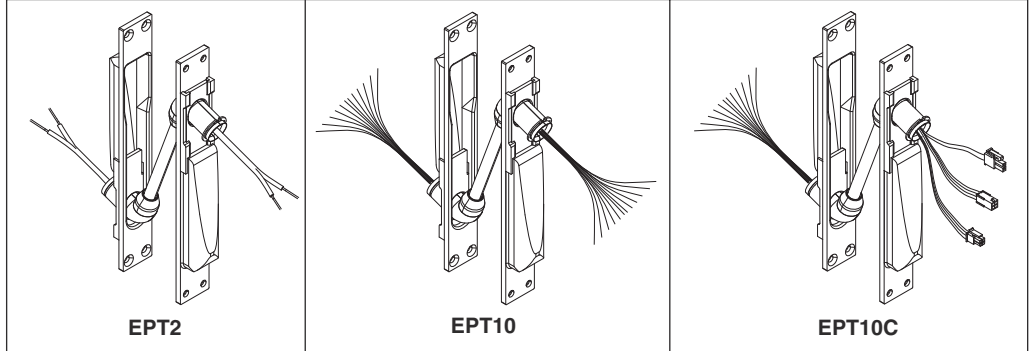

- A. Frame Backbox
- B. Metal - #10-24 x 3/8" Flat Phillips Head Machine Screw (4)
Wood - #10 x 3/4" Flat Phillips Head Wood Screw (4)
- C. EPT2 - Wire Connectors 12 Gauge Yellow (4)
EPT10 - Wire Connectors 18 Gauge Violet (20)
EPT10C - Wire Connectors 18 Gauge Violet (20)
- D. EPT Assembly
- E. Metal - #10-24 x 3/4" Flat Phillips Head Machine Screw (8)
Wood - #10 x 3/4" Flat Phillips Head Wood Screw (8)
- F. Door Backbox
- G. Strain Relief

General Information

An electric power transfer (EPT) provides a wiring path from the door to the frame.

These instructions assume that a factory-prepped door and frame are being used. If the door and frame have not been factory-prepped, see the included dimensioned template.

Before beginning the installation, review "Specifications" and "Warnings".

Specifications

Applications

EPT **can** be used for:

- Door Thickness - 1-3/4" minimum
Note: The following specifications apply to a 1-3/4" thick door.
- 0 - 180° opening with up to 5" butt hinges
- 0 - 180° opening with up to 3/4" offset pivots
- 0 - 130° opening with 5-1/2" butt hinges
- 0 - 110° opening with 6" butt hinges

EPT **cannot** be used for:

- 1-1/2" offset pivots
- larger than 6" butt hinges
- pocket pivots
- swing clear hinges
- center hung door (center pivot)
- balanced door

Electrical Ratings

EPT2

- Two 18AWG wires
- Max. Rating: 24VDC, 5A or 120VAC NEC Class 3

EPT10 & EPT10C

- Ten 24AWG wires
- Max Rating: 24VDC, 1A

Read all Warnings Before Starting Installation!

CAUTION

Do not exceed rated specifications (shown above).

CAUTION

EPT must be installed in accordance with these instructions by a qualified electrician.

CAUTION

Wiring must be in accordance with all local codes and regulations.

Installation

1 Use Template from Back Page to Verify Preparation

2 Mount Frame Backbox

- A. Remove knockout from top
- B. Install 1/2" conduit, if used
- C. Pull 5" of field wiring through knockout

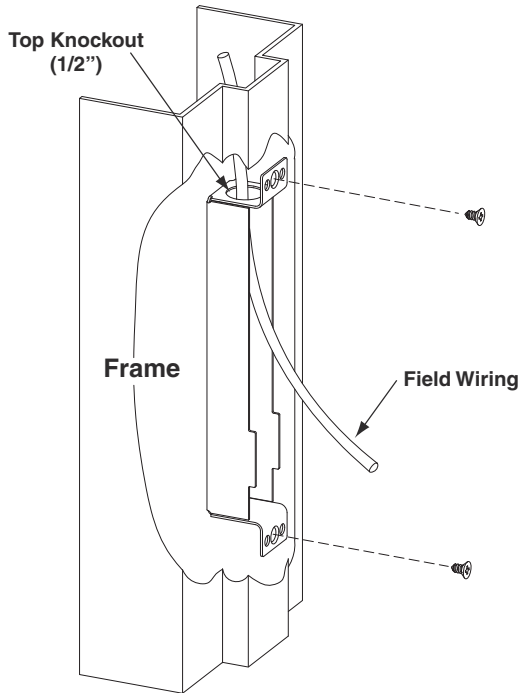

3 Mount Door Backbox

- A. Ensure backbox bevel matches door bevel
- B. Remove knockout:
 - from bottom for **metal** doors
 - from back for **wood** doors
- C. Pull 5" of field wiring through knockout
- D. Install strain relief

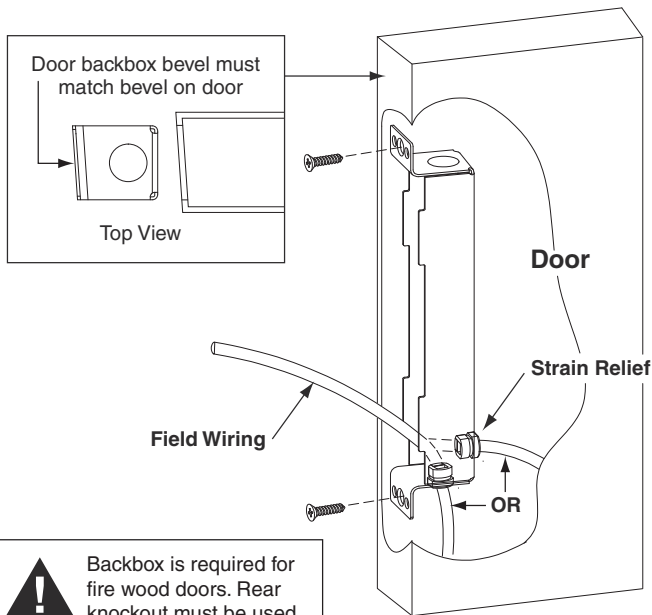

4 Connect Wires

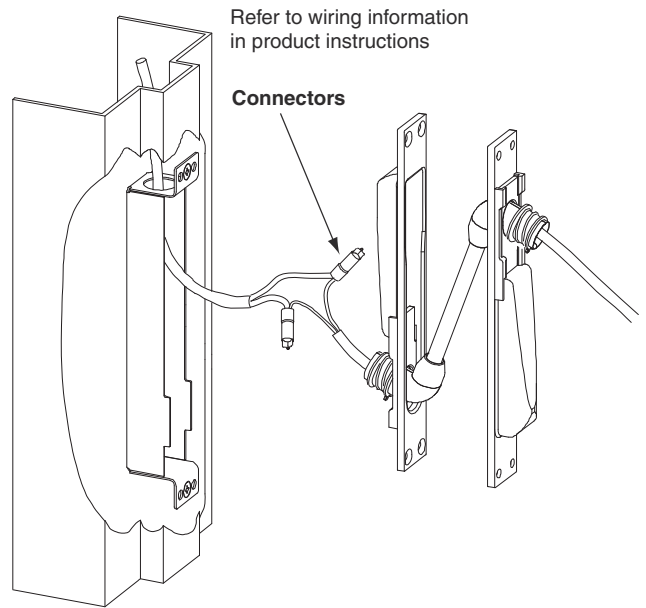

5 Mount EPT Assembly

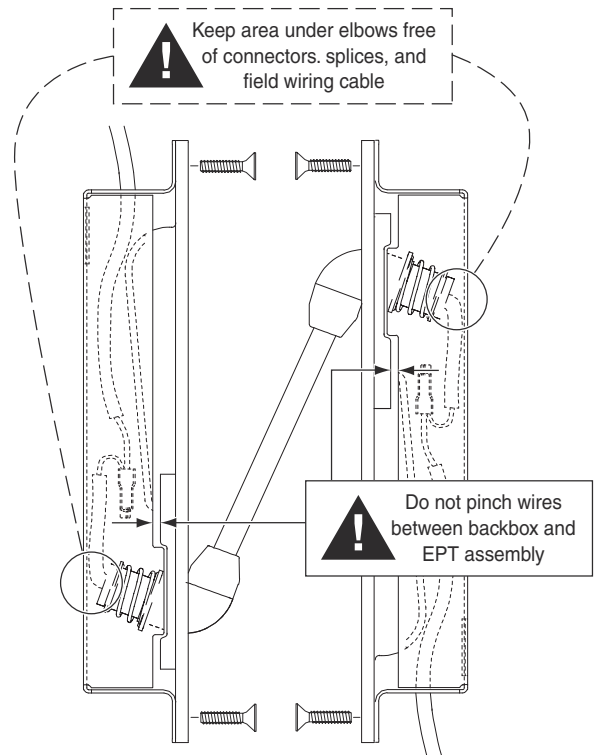

6 Verify that door opens and closes properly without binding and that electrical components function

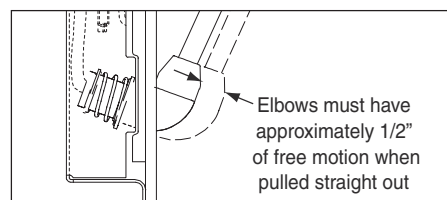

Template

Note: This drawing is not to scale

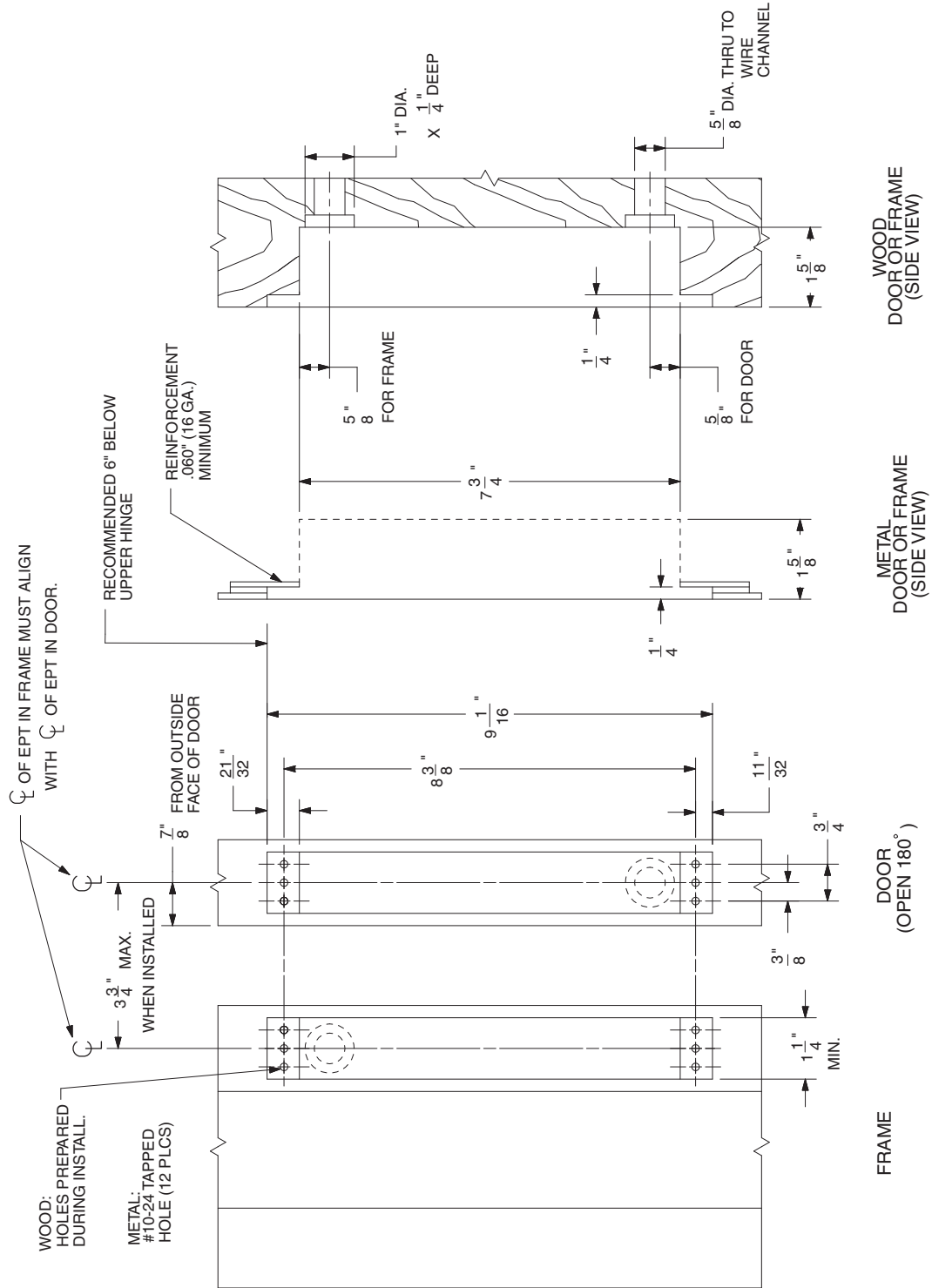

*ALL DIMENSIONS ARE TYPICAL