

# TST EWA4-B0505

Door controller

## Operating manual

**EN**

**IMPORTANT**

Read the instructions carefully before use!

Ensure that these instructions are readily available!



## 1 User information

**Change date** 25-11-05

This edition replaces all earlier versions.

The specifications in this document are subject to change without notice.

Copyright© FEIG ELECTRONIC GmbH

All rights reserved.

**"The transfer or reproduction of this document, as well as the assessment and dissemination of its content, are prohibited unless expressly permitted. Infringements are subject to compensation. All rights reserved in the event of patent, utility model or design registration."**

### 1.1 Contact details of the manufacturer

If you need spare parts or accessories or have technical questions, please contact our technical customer support.

FEIG ELECTRONIC GmbH

Industriestrasse 1A

D – 35781 Weilburg

Germany

Web: [www.feig.de](http://www.feig.de)

Mail: [info@feig.de](mailto:info@feig.de)

Tel: + 49 (0) 6471/ 3109-0

## 2 Content

<b>1</b>	<b>User information</b>	<b>2</b>
<b>1.1</b>	<b>Contact details of the manufacturer</b>	<b>2</b>
<b>2</b>	<b>Content</b>	<b>3</b>
<b>3</b>	<b>About these instructions</b>	<b>6</b>
<b>3.1</b>	<b>Keep the assembly instructions</b>	<b>6</b>
<b>3.2</b>	<b>Terms, symbols and abbreviations used</b>	<b>7</b>
3.2.1	Safety sign	7
3.2.2	Terms	8
3.2.3	Text labelling	8
3.2.4	Colour coding	9
<b>4</b>	<b>Safety</b>	<b>10</b>
<b>4.1</b>	<b>Intended use</b>	<b>10</b>
<b>4.2</b>	<b>Incorrect use</b>	<b>10</b>
<b>4.3</b>	<b>Safety instructions</b>	<b>11</b>
4.3.1	Safety instructions for installation	11
4.3.2	Safety instructions for the electrical connection	13
4.3.3	Safety instructions for commissioning	15
4.3.4	Notes for safe operation	16
<b>4.4</b>	<b>Safety functions in accordance with EN 12453:2022</b>	<b>17</b>
4.4.1	Connection example for testing: Description for a transmitter-receiver light barrier	17
4.4.2	Configuration	18
<b>4.5</b>	<b>Personnel qualification</b>	<b>19</b>
<b>4.6</b>	<b>Duty of care of the operating company</b>	<b>20</b>
<b>5</b>	<b>Scope of delivery</b>	<b>21</b>
<b>6</b>	<b>Product description</b>	<b>22</b>
<b>6.1</b>	<b>Accessories</b>	<b>22</b>

<b>6.2</b>	<b>Protection devices .....</b>	<b>23</b>
<b>6.3</b>	<b>Structure and function .....</b>	<b>24</b>
<b>6.4</b>	<b>Symbols on the device .....</b>	<b>24</b>
6.4.1	Warning stickers .....	24
6.4.2	Type plate .....	25
<hr/>		
<b>7</b>	<b>Installation</b>	<b>26</b>
<hr/>		
<b>7.1</b>	<b>Selecting the installation location .....</b>	<b>26</b>
<b>7.2</b>	<b>Installing the housing .....</b>	<b>27</b>
7.2.1	Drilling template for housing.....	28
<b>7.3</b>	<b>Opening the housing .....</b>	<b>29</b>
<b>7.4</b>	<b>Installing the motor cable .....</b>	<b>31</b>
<hr/>		
<b>8</b>	<b>Main connections</b>	<b>33</b>
<hr/>		
<b>8.1</b>	<b>Connection diameters for the terminals on printed circuit boards.....</b>	<b>33</b>
<b>8.2</b>	<b>Overview of main connections .....</b>	<b>34</b>
8.2.1	Connecting the motor cable (three-phase motor with three-phase mains connection).....	36
8.2.2	Connecting the brake .....	37
<hr/>		
<b>9</b>	<b>Accessories for electrical connections</b>	<b>39</b>
<hr/>		
<b>9.1</b>	<b>Accessories overview .....</b>	<b>39</b>
<b>9.2</b>	<b>Terminal description .....</b>	<b>42</b>
<b>9.3</b>	<b>Connecting different limit switch systems .....</b>	<b>44</b>
<b>9.4</b>	<b>Connect the safety edge.....</b>	<b>45</b>
9.4.1	Connect the safety edge to the first evaluator .....	47
9.4.2	Connecting the second safety edge to the second evaluator .....	49
<b>9.5</b>	<b>Connecting the photoeye .....</b>	<b>52</b>
<hr/>		
<b>10</b>	<b>Operation</b>	<b>53</b>
<hr/>		
<b>10.1</b>	<b>Switch door control on/off.....</b>	<b>53</b>
<b>10.2</b>	<b>Keypad commands.....</b>	<b>53</b>
<b>10.3</b>	<b>Activating the DIP switch .....</b>	<b>54</b>
<b>10.4</b>	<b>Initiating parameter setting mode.....</b>	<b>55</b>

---

<b>10.5</b>	<b>Editing the parameter settings .....</b>	<b>55</b>
<b>10.6</b>	<b>Exiting parameter setting mode .....</b>	<b>56</b>
<b>10.7</b>	<b>Initiating a restart .....</b>	<b>58</b>
<b>10.8</b>	<b>Changing the access level .....</b>	<b>58</b>
<hr/>		
<b>11</b>	<b>Configure door control unit .....</b>	<b>59</b>
<hr/>		
<b>11.1</b>	<b>Basic settings .....</b>	<b>59</b>
<b>11.2</b>	<b>Adjusting the brake.....</b>	<b>61</b>
<b>11.3</b>	<b>Setting the door limit positions .....</b>	<b>61</b>
11.3.1	Electronic limit switch system .....	62
11.3.2	Mechanical limit switch system.....	62
<hr/>		
<b>12</b>	<b>Function-enhancing configurations .....</b>	<b>65</b>
<hr/>		
<b>12.1</b>	<b>Correcting the door limit positions.....</b>	<b>65</b>
12.1.1	Teaching in the door limit positions again.....	65
12.1.2	Fine adjustment of the door limit positions .....	66
<b>12.2</b>	<b>Adjusting the end holding point of the door .....</b>	<b>66</b>
<hr/>		
<b>13</b>	<b>Messages on the display .....</b>	<b>69</b>
<hr/>		
<b>14</b>	<b>Troubleshooting .....</b>	<b>74</b>
<hr/>		
<b>15</b>	<b>Maintenance and disposal .....</b>	<b>76</b>
<hr/>		
<b>15.1</b>	<b>Maintenance.....</b>	<b>76</b>
<b>15.2</b>	<b>Disposal of the product .....</b>	<b>76</b>
<hr/>		
<b>16</b>	<b>Technical data .....</b>	<b>77</b>
<hr/>		
<b>16.1</b>	<b>Dimensions .....</b>	<b>78</b>
16.1.1	Housing dimensions.....	78

---

---

### 3 About these instructions

These instructions describe the installation and commissioning process for the **TST EWA4-B0505** door control unit.

For this, please take note of the following:

- The instructions only show the control functions to a partial extent and do not constitute a warranty of characteristics. Further descriptions of individual door functions and specifications of the control unit for other control unit functions can be requested from FEIG ELECTRONIC GmbH.
- The description of the products, their use, options and performance data do not constitute warranted characteristics and are subject to technical changes.
- We have ensured to the best of our efforts that these instructions do not contain any errors. Nevertheless, since errors can never be completely ruled out, we would be grateful to you for drawing our attention to these at any time.
- The installation recommendations contained in this document assume favourable general conditions. FEIG ELECTRONIC GmbH assumes no liability for the proper operation of the equipment in third-party environments.
- The completeness of the operating instructions of the complete machine (in this case: of the door) is the sole responsibility of the distributor of the machine. The installation instructions for the control unit are to be composed in one of the official languages of the European Community accepted by the manufacturer of the machine in which this control unit is to be installed.
- FEIG ELECTRONIC GmbH does not warrant that the information contained in this document is free from third-party intellectual property rights. FEIG ELECTRONIC GmbH does not grant any licences to its own or third-party patents or other industrial property rights with this document.
- Only the direct contracting parties shall be entitled to warranty claims against FEIG ELECTRONIC GmbH; warranty claims are non-transferable. The warranty covers only products supplied by FEIG ELECTRONIC GmbH. Liability for the entire system is excluded.
- The following information describes standard applications that may not necessarily match the actual application. The actual application is provided by the manufacturer of the door as part of the overall documentation or as part of the operating instructions of the door.
- If you have any questions about the product, please contact your supplier.

#### 3.1 Keep the assembly instructions

- If possible, keep the installation instructions in the immediate vicinity of the product and protected from harmful environmental influences.
- The content must be permanently and clearly legible throughout the service life of the product.
- The assembly instructions must be available to the personnel at the workplace at all times.

## 3.2 Terms, symbols and abbreviations used

### 3.2.1 Safety sign

The following symbols are used in these instructions to indicate various hazards. The specifications of these instructions require compliance to ensure personal safety.

#### **DANGER**

Warns of an **imminently** hazardous situation, which will result in death or irreversible injury if not avoided.

#### **WARNING**

Warns of a potentially dangerous situation of moderate severity, which can result in serious damage to the device or very serious injuries if not avoided.

#### **CAUTION**

Indicates potential danger for persons if the procedure is not carried out as described.

#### **ATTENTION**

Indicates an important function or hazard of the product.

### 3.2.2 Terms

#### DIP switch

Switch on the control board

#### Hold-open time

Waiting time before the door is closed from the limit position for door open

#### Deadman travel

Door travel that is only executed as long as the OPEN/UP or CLOSE/DOWN button remains pressed; the door stops immediately as soon as no more movement commands are issued

#### Door cycles

Number of times the door opens and closes, 1 door cycle includes one opening and closing movement

#### Factory defaults





Values in the respective parameters that are set by FEIG ELECTRONIC on delivery

#### Access level

Access authorisation to the parameter settings using different passwords; certain parameters are assigned to each access level

### 3.2.3 Text labelling

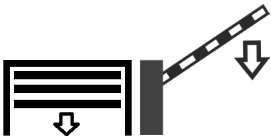
*The text contains labels or icons with the following meanings:*

Symbol	Description
	Refers to information that is useful but not strictly necessary to know for use of the product.
	The indicated activity is likely to require a certain degree of strength.
	7-segment display
	Door or gate closes.
	Door or gate opens.

### 3.2.4 Colour coding

The colours of different wires are designated according to the colour coding scheme of DIN IEC 757. The colour codes can be linked by means of a plus symbol (+). For example, a three-wire cable with two black, one blue and one green/yellow wire is represented as follows: BK + BK + BU + GNYE.

Colour	Abbreviation
Black	BK
Brown	BN
Red	RD
Orange	OG
Yellow	YE
Green	GN
Blue	BU
Violet	VT
Grey	GY
White	WH
Pink	PK
Gold	GD
Turquoise (Petrol)	TQ
Silver	SR

## 4 Safety

### 4.1 Intended use

- The TST EWA4-B0505 control unit is designed for the operation of an asynchronous motor in the power range up to 4 kW at 400 V and is suitable for the operation of motorised industrial or commercial doors and gates in accordance with the DIN EN 13241 standard.
- Intended use includes compliance with all the specifications made in this assembly manual pertaining to assembly, installation and start up, the applicable safety instructions and consideration of the technical data.
- The control unit is only permitted to be operated with accessories authorized by FEIG ELECTRONIC GmbH.
- All assembly, installation, commissioning and maintenance work performed on doors or gates or on the drive units intended for the doors or gates are to be performed exclusively by qualified specialist personnel as defined by the EC Machinery Directive. In particular, the following regulations require compliance: VDE 0100, EN 50110, EN 60204, EN 60335 inc. part 103, the fire protection regulations, accident prevention regulations and the applicable regulations for industrial doors (EN12453, EN12978) and machine safety (EN ISO 13849, EN 62061).

### 4.2 Incorrect use

Incorrect use includes all use of the control unit that is classed as non-intended use.

This device is not intended for use by persons (including children) with limited physical, sensory or mental abilities or lacking in experience and/or knowledge, unless they are supervised by a person responsible for their safety or if they have received instructions regarding the use of the device. Children should be supervised to ensure that they do not play with the device. Keep remote controls away from such persons.

Should the control unit be subject to any use other than that described, the operating company will be liable for the resulting damage. This applies to unauthorised alterations, modifications or programming to the controller and its components as well as ignoring of warnings and safety instructions.

The following scenarios in particular are classified as incorrect use:

- Use outside the specified assembly conditions and safety distances to the surroundings (place and temperature).
- Use in an explosive or easily flammable environment.
- Use with defective parts.
- Use with spare parts and extension boards that have not been approved by FEIG ELECTRONIC GmbH.
- Use without safety devices.

## 4.3 Safety instructions

### 4.3.1 Safety instructions for installation

#### WARNING

##### **Important instructions for safe installation!**

Observe all instructions; incorrect installation can result in serious injuries!

#### **Installation location**

- The installation location must be selected so that the door area can be seen by the operator. If this is not possible for structural reasons, you must ensure that deadman operation is only accessible to qualified specialist personnel or that the feature is disabled altogether.
- The installation location must be selected so that the control unit is protected against damage (see notes under "Device protection"). Under some conditions, damage to the control unit may result in further significant consequential damage to the control unit, as well as hazards for the user.
- Do not touch any electronic parts, in particular the components of the processor circuit. Electronic components are sensitive to electrostatic charge. Marked components must only be handled by qualified specialist personnel after potential equalisation with special equipment. The installation location must comply with the ESD guidelines (ESD = Electro Static Discharge).

#### **Installation**

- Prior to installation, check the control unit for transport damage or other occurrences of damage. Under some conditions, damage to the interior of the control unit may result in further significant consequential damage to the control unit, as well as hazards for the user. If the control unit or keypad is damaged, it must be replaced!
- Prior to and during installation of the control unit, the system must be turned off.
- The control unit may only be opened if all the poles of the supply voltage have been turned off. It is not permitted to turn on or to operate the control unit when it is open.

#### **ATTENTION**

##### **Important instructions!**

Failure to observe the safety instructions may result in damage to the control unit.

#### **Device protection**

- Before opening the housing cover, ensure that no drilling swarf or similar remnants that could fall into the housing are present on the housing cover.
- The control unit must not be mounted on flammable surfaces (e.g. wood of  $\leq 2$  mm thickness) or in environments with highly flammable substances (e.g. carpentry).
- The installation location must be selected so that the control unit is not exposed to direct sunlight and other weather influences cannot have a direct effect on the control unit.
- It must be ensured that no transmission of mechanical vibrations from the door to the control unit is possible (e.g. installation on a brick wall).
- The maximum cable length between the drive and control unit must not exceed 30 metres.
- If the control unit is installed in an additional housing, e.g. in a barrier housing, care must be taken to provide a sufficient volume of air around the controller. This must be at least  $0.02 \text{ m}^3$ . Should cooling not be sufficient, an additional heat sink can be inserted between the control unit housing and the additional housing to dissipate the heat to the outside.

**Cable entries and connection cables**

- The following applies to control units in the housing: Unused cable glands must be sealed via suitable means to guarantee the IP 54 protection rating of the housing.
- The control unit must never be operated with the CEE plug detached, unless the supply voltage to the control unit can be cut on all poles via a corresponding switch. The mains plug or the substitute switch must be easily accessible.
- The control unit must always be installed so that the cable entries point downwards.
- Install the control unit and cable glands without mechanical tension. The cable glands should not be subjected to tensile stress.

### 4.3.2 Safety instructions for the electrical connection

#### WARNING

##### **Important instructions for the electrical connection!**

Make sure to observe all instructions! Incorrect connection can result in serious injuries!

##### **Connection, testing and maintenance work**

- Before accessing the connection terminals, all supply circuits must be switched off.
- Hazardous voltages remain stored in the intermediate circuit capacitors for up to 5 minutes after the power supply has been turned off. The discharge time until voltages fall below 60 VDC is a maximum of 5 minutes. Touching internal components of the control unit within this discharge time is hazardous.
- A defective switching power supply can considerably increase the discharge time of the intermediate circuit capacitors before reaching a voltage less than 60 VDC. In this case, discharge times of up to 10 minutes are possible.
- Even if a motor is not rotating, this does not indicate that it has been galvanically isolated from the power grid! The mains connection terminals and motor terminals can still carry dangerous voltages, e.g. in the event of a stop or emergency stop.
- Never operate the control unit without having connected the protective earth conductor. The absence of a protective earth conductor will result in hazardous voltages on the control unit housing caused by terminal capacitances. The RFI filters integrated into the control unit may increase the leakage current up to a max. of 7 mA (see DIN EN 60335-1 section 16.2). A corresponding routine test was carried out by the manufacturer before delivery of the device.
- Connect the cables to the connection terminals first, then attach them to the connectors! Only by following this approach is it possible to ensure a safe contact of the connection terminals to the plug connectors.
- During the downtime, no galvanic isolation exists between the amplifier module and the motor terminal.
- If the 24 V control voltage is short-circuited or overloaded, the switching power supply will not start up, even though the intermediate circuit capacitors are charged. The displays remain turned off. The power supply can only be restarted after eliminating the short circuit or the overload condition.
- In the case of drive units with an electromechanical brake, ensure that the brake is equipped with adequate suppression. We recommend the use of RC-elements for interference suppression purposes.
- Do not leave any mounting or wiring residues in the control unit housing. Electrically conductive residues can cause serious damage to the circuit board.

##### **After the electrical installation**

- After the installation has been completed, check that the system has been configured correctly and that the safety system works properly.
- If the potential-free contacts of the output relays or other terminals are supplied by an external voltage, i.e. dangerous voltages are still present after switching off the control unit or disconnecting power, you must attach a suitable, clearly visible warning sign to the control unit housing.

**ATTENTION****Important instructions!**

Failure to observe the safety instructions may result in damage to the control unit.

**Device protection**

- Fast-running plastic foil doors may produce very high build-ups of electrostatic charge on the foil. A discharge of these voltages may damage the control unit. The safety edge connections are particularly at risk. As a countermeasure, a discharge device on the door leaf is recommended (e.g. earthing, brushes).

**Connections**

- Terminals can be damaged. There are springs in the terminals that ensure secure contact with the pin headers. To connect the cables, the terminals on the door control unit must always be disconnected first.
- The connection of the cables fed into the control unit should be kept short and routed as directly as possible to the connection terminal (no "spare loops" for the individual wires).
- Induction loop connections must be routed separately from all other lines carrying mains voltage. The loop connections must be twisted in pairs up to the internal control terminal.
- For the use of position sensors for position detection, we recommend connection via shielded cables.

**After the electrical installation**

- Before turning on the control unit for the first time and after completion of the wiring, check whether all motor connections are tight on the control unit and the motor side and whether the motor is correctly wired in star or delta configuration. Loose connections to the motor usually result in damage to the control unit.

### 4.3.3 Safety instructions for commissioning

#### **⚠ WARNING**

##### **Important instructions!**

Disregarding the safety instructions can lead to health hazards.

When starting up and operating the control unit, the following important safety instructions as well as the installation and wiring information must be strictly observed.

##### **Operation of the control unit**

- Never operate the control unit while the cover is removed.
- When moving the door in deadman operation, ensure that the operator has an unobstructed view of the door area. In deadman operation, safety devices such as the safety edge and light barrier cannot become effective even if the safety device has been triggered or is defective. If a line of sight to the door cannot be established for structural reasons, you must ensure that deadman operation can only be executed by qualified specialist personnel, or that the function is disabled altogether.
- To prevent damage to the keypad, do not use pointed objects to operate the keys. The keypad is designed to only be pressed by human fingers.

##### **Parameter settings**

- The parameter settings are classified according to access levels. Access to the respective access level is obtained via a password. Depending on the access level, a variety of different parameters are visible. Changes to the parameter settings must only be made if the function of the parameter is known.
- In order to avoid failure and/or hazards resulting from unauthorized access, passwords must only be shared with qualified specialist personnel.
- The parameter settings, including the speed and the functionality of all protection devices, must be checked.

#### **ATTENTION**

##### **Important instructions!**

Failure to observe the safety instructions may result in damage to the control unit.

##### **Before commissioning**

- Before switching on the controller supply for the first time, ensure that the plug-in modules have been inserted in the correct locations. If the cards are inserted out of position or twisted, the control unit may become damaged. The same applies to the installation of non-approved third-party products.
- After completion of the wiring and before turning on the control unit for the first time, check that all motor connections are tight on the control unit side and the motor side and that the motor is correctly wired in star or delta configuration. Loose connections to the motor usually result in damage to the inverter.
- Check the electrical connection again before starting the control unit. Incorrect connections may damage the unit.
- Switching on or operating the control unit in the presence of condensation is not permitted. This may result in damage to the control unit.

#### 4.3.4 Notes for safe operation

##### WARNING

###### **Important instructions!**

Disregarding the safety instructions can lead to health hazards.

When starting up and operating the control unit, the following important safety instructions as well as the installation and wiring information must be strictly observed.

###### **Damage to the device**

- If the connection cable for this device is damaged, it must be replaced by the manufacturer, its customer service department or a qualified specialist in order to avoid any health risks due to damage to the device (according to connection type Y as per EN 60335-1).

###### **Installation, commissioning and operation of the control unit**

- Improper integration of the control unit into the door system – e.g. missing sensors, incorrect parameter setting, speed set excessively high, etc. – presents the considerable risk of the door being operated without adequate safety precautions.
- It is prohibited to start up this control unit until it has been properly attached to a door that complies with the provisions the EC Machinery Directive and for which an EC declaration of conformity according to Annex II A of the Directive has been obtained.
- The control unit must never be operated with a damaged keypad or a damaged viewing window. Otherwise, emergency operation will no longer be possible (e.g. deadman operation). Damaged keypads and viewing windows must be replaced.
- To prevent damage to the keypad, do not use pointed objects to operate the keys. The keypad is designed to only be pressed by human fingers.
- Depending on the type of the door, it may be necessary that the door can only be operated when it is within visual range. In such cases, it is not permitted to use a remote control (e.g. wireless) to issue commands.
- When moving the door in deadman operation, ensure that the operator has an unobstructed view of the door area. In deadman operation, safety devices such as the safety edge and light barrier cannot become effective even if the safety device has been triggered or is defective. If a line of sight to the door cannot be established for structural reasons, you must ensure that deadman operation can only be executed by qualified specialist personnel, or that the function is disabled altogether.

###### **Connection, testing and maintenance work**

- Wiring, testing and maintenance work on an open control unit must only be performed when the power has been turned off.
- All protection devices must be checked for proper functionality after they have been connected and adjusted.
- The setting of parameters, switching of bridges and connection of other controls must only be carried out by qualified personnel.

#### 4.4 Safety functions in accordance with EN 12453:2022

EN 12453:2022 places special requirements on safety-related signals. These signals must comply with a minimum performance level of PL “c”, cat. 2 in accordance with EN 13849-1. To guarantee these safety requirements, the complete chain of sensors, actors and if necessary, the wiring must be taken into account accordingly. This concerns (among other elements):

- Path restriction units (limit switch)
- Actuators with automatic reset
- Slack rope switches
- Escape door switches

To comply with the standard requirements, these signals can be connected via the emergency stop inputs of the control unit (terminal no. 31–32 and 41–42).

Alternatively, standard digital inputs can be used. In this case, an additional output must be configured as a test output and integrated in the signal chain.

##### 4.4.1 Connection example for testing: Description for a transmitter-receiver light barrier

The transmitter is supplied with 24 V via a test output.

In a test case, the output is switched off so that the transmitter is voltage-free.

The receiver now switches the input.

The control unit checks whether the input actually switches and also switches back:

Yes: Testing successful

No: Error message F.928

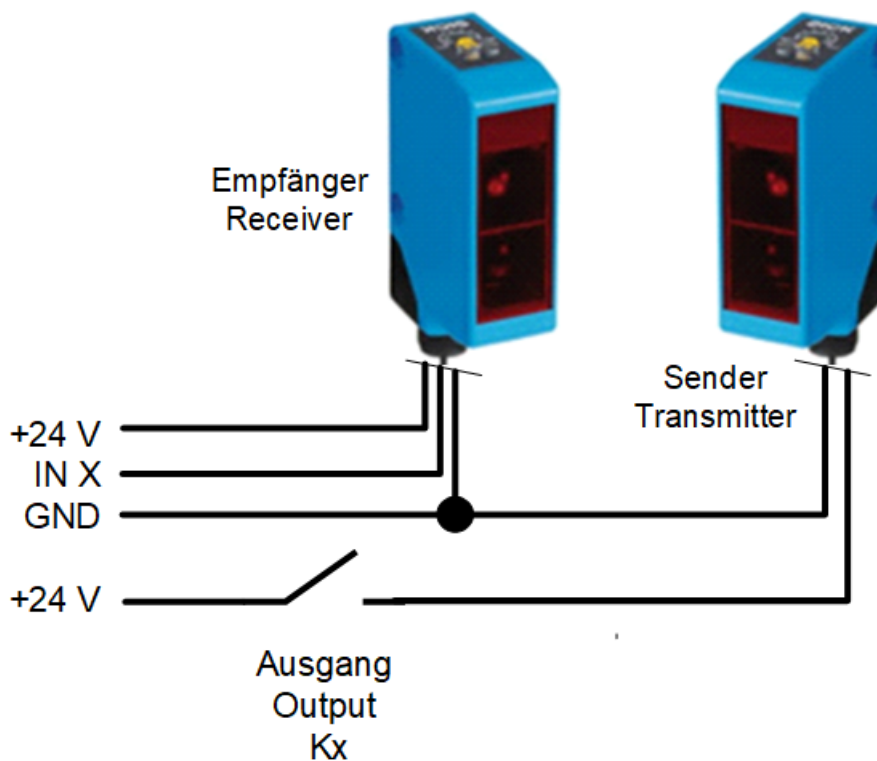

#### NOTE

Both digital outputs and relays can be used as a test output.

#### 4.4.2 Configuration

To activate the testing function, the inputs and a relay for each must be configured for testing.

**Input parametrisation P.5xA:**

P.5xA = 0: No testing activated P.5xA = 1: Testing the input upon reaching the limit position OPEN and after switch-on

P.5xA = 2: Testing the input upon reaching the limit position CLOSE and after switch-on

**X = number of the input to be configured.**

**Configuring the output P.7x0:**

P.7x0 = 17: Testing in limit position CLOSE

P.7x0 = 25: Testing in limit position OPEN

**Relays switched if testing inactive.**

**X = number of the output to be configured.**

## 4.5 Personnel qualification

The TST EWA4-B0505 control unit from FEIG ELECTRONIC GmbH is only permitted to be operated and maintained by persons who comply with the requirements outlined here, and who are familiar with the safety standards of electrical drive and automation technology.

All the person groups specified here must have read and understood these installation instructions before using the control unit.

Persons under the influence of drugs or alcohol or who have taken medicines that restrict their reactive ability are not permitted to perform work on the control unit.

The instructions differentiate between the following person groups:

Person group	Requirement	Authorisation/task
Operating company	The operating company is in possession of the control unit and is responsible for ensuring its intended use. The operating company must ensure that all persons performing tasks on the control unit have been given professional training and fulfil the requisite bodily and mental requirements for dealing with the control unit.	<ul style="list-style-type: none"> <li>▪ <i>Deploy authorised personnel</i></li> <li>▪ <i>Deploy the product in accordance with its intended use</i></li> <li>▪ <i>Training</i></li> </ul>
Operator	The operator has been informed of the function of the control unit and is able to operate the assembled and installed control unit.  Operators include all persons who deal with the machine over its various life phases. This can be specialist personnel with or without special training or laypersons.	<ul style="list-style-type: none"> <li>▪ <i>Operation</i></li> </ul>
Qualified specialist	The qualified specialist has been trained in working with electrical work equipment and has been informed of the possible hazards caused by improper handling.  The qualified specialist is familiar with the necessary protective measures and devices. Furthermore, as a result of professional training and experience, as well as recent professional activity, they have the required specialist knowledge to inspect the tools.	<ul style="list-style-type: none"> <li>▪ <i>Unpacking</i></li> <li>▪ <i>Assembly</i></li> <li>▪ <i>Installation</i></li> <li>▪ <i>Startup</i></li> <li>▪ <i>Repair</i></li> <li>▪ <i>Operation</i></li> <li>▪ <i>Programming</i></li> <li>▪ <i>Disposal</i></li> <li>▪ <i>Checking</i></li> </ul>
Electrician	The electrician is qualified to work in the working environment of electrical systems; their knowledge and experience enable them to perform and monitor electro-technical work without danger. The electrician is familiar with the relevant standards and specifications and knows the specifications of the valid legal regulations pertaining to accident prevention. They take part in regular further training measures.  Electricians currently undergoing training (also minors) are only permitted to perform work under the supervision of an experienced electrician; this requires the express permission of the operating company.	<ul style="list-style-type: none"> <li>▪ <i>Unpacking</i></li> <li>▪ <i>Assembly</i></li> <li>▪ <i>Installation</i></li> <li>▪ <i>Startup</i></li> <li>▪ <i>Repair</i></li> <li>▪ <i>Operation</i></li> <li>▪ <i>Programming</i></li> <li>▪ <i>Disposal</i></li> <li>▪ <i>Instruction</i></li> </ul>
Manufacturer	The manufacturer is involved in the design and production of a partly completed machine and accepts responsibility for conformity of the machine part with the directive.	<ul style="list-style-type: none"> <li>▪ <i>Design</i></li> <li>▪ <i>Production</i></li> <li>▪ <i>Disposal</i></li> </ul>

Distributor	The distributor provides a complete machine to the market in terms of its distribution or use.	▪ <i>Distribution</i>
-------------	--	-----------------------

#### 4.6 Duty of care of the operating company

FEIG ELECTRONIC GmbH maintains a certified quality management system in accordance with DIN EN ISO 9001.

The faultless safety condition of the control unit and its function are checked in accordance with valid regulations before it leaves our factory. The operating company is to check this state after transport and before installation of the control unit.

The operating company is responsible for maintaining this state by ensuring that...

- ...the controller is installed in accordance with the assembly, installation and safety regulations outlined here.
- ...damage is rectified immediately by qualified specialist personnel.
- ...the controller is operated in a faultless state.
- ..the controller is assembled, installed and commissioned by qualified specialist personnel only.

## 5 Scope of delivery

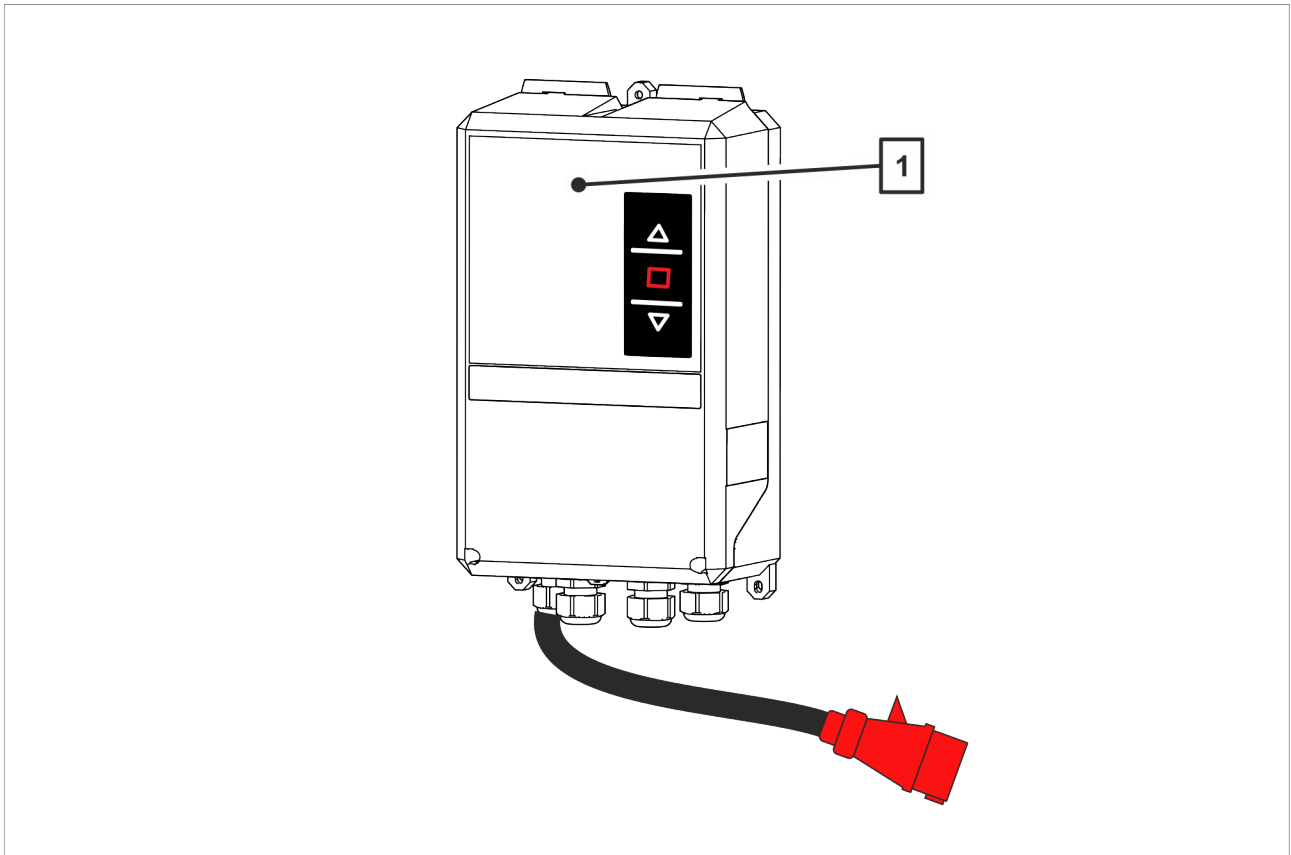

---

1 TST EWA4-B0505

---

## 6 Product description

The **Door controller TST EWA4-B0505** is an electronic reversing control system that can be used to operate doors and barriers (system) without damaging the mechanics.

The control unit is built into a plastic housing and its function can be expanded with additional accessories.

### 6.1 Accessories

The following accessories can be connected to the door control unit **TST EWA4-B0505**:

Most of the products are part of the FEIG ELECTRONIC product range.

Accessory	Function
Limit switch <b>Note:</b> The connection of a limit switch is mandatory.	Detecting specific door positions (OPEN or CLOSE limit position)
Position encoder	
Safety edges	Protection device on the bottom edge of the door
Light curtain	Non-contact protection device using light beams, replacement for safety edge
Photoeye	Additional non-contact protection device
Radio receiver	Reception of opening signals
External control unit	Control of the door
Induction loop detectors	Evaluation of loops that are used to control the door
Resistance evaluator	Evaluation of pull-in safety devices, Slack rope switches, escape door switches, etc.
Expansion boards	Expansion of inputs and outputs, interface expansion
Relay	Interface extension
Motion detector	Control of the door
Distributor box	Connection of CAN components and accessories
Plain text display	Display of parameters and associated short text

## 6.2 Protection devices

Depending on the door and its intended use, a protection device must be connected. Protection devices must never be overridden or rendered ineffective. The following protection devices can be operated with control units from FEIG ELECTRONIC GmbH.

### Safety edge

The safety edge is a safety device that triggers a reversal of the door. If, for example, there is an obstacle in the door area during door travel, the safety edge is triggered by contact with the obstacle. The door is stopped and, after a short pause, opened in the opposite direction (it is reversed via the safety edge).

If the automatic closing system is active and an obstacle remains in the door path, the door would constantly move towards the obstacle and reverse. To avoid this, parameters can be set to determine how often the door is permitted to reverse until it stops in the OPEN limit position.

### Light curtain

The light curtain from FEIG ELECTRONIC GmbH can be used as a stand-alone protection device. Please make sure that the door blade completely covers the light lines of the light curtain. The light curtain also permits the automatic teach-in of the CLOSE limit position.



Further information on the respective accessories can be found in the corresponding instructions.

### 6.3 Structure and function

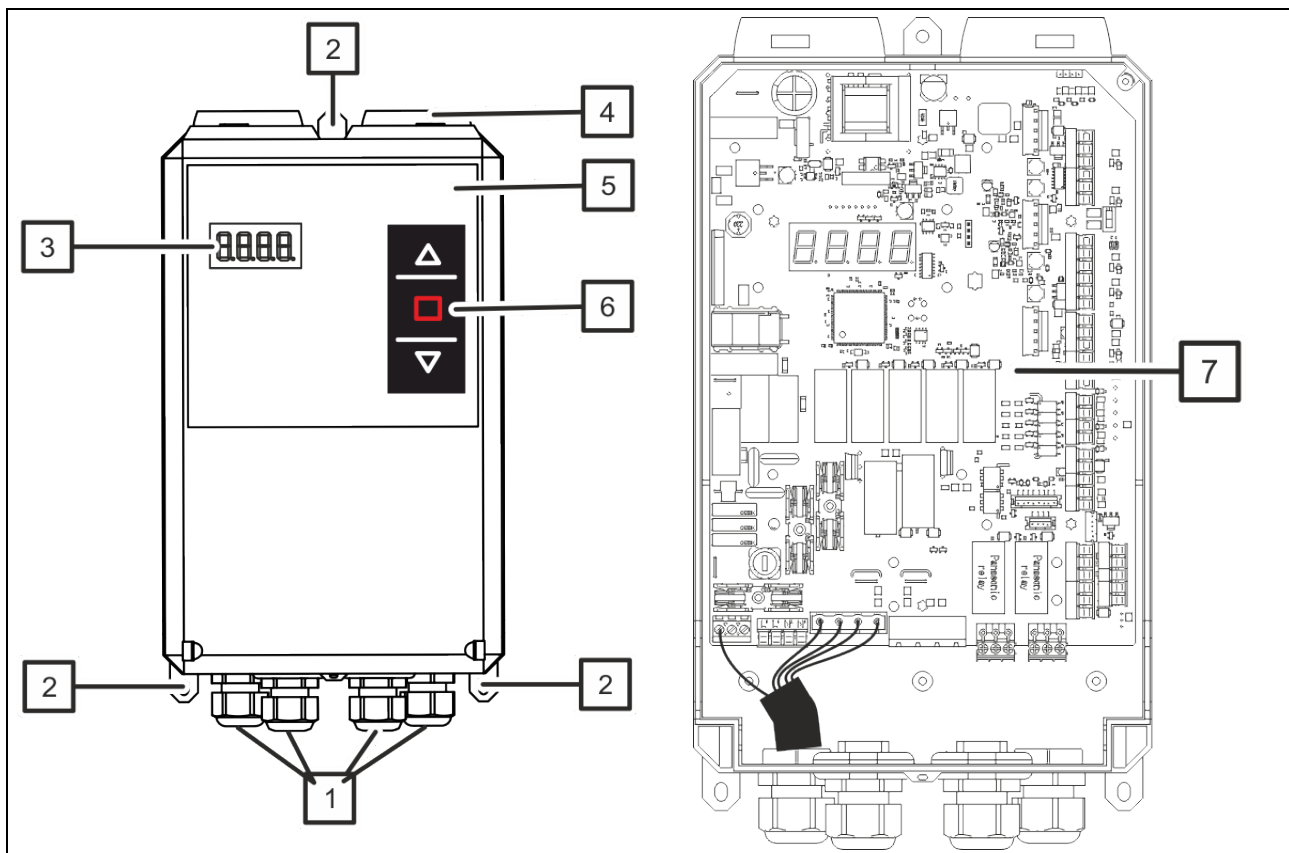



- |                         |                  |
|-------------------------|------------------|
| 1 Cable entry           | 5 Housing cover  |
| 2 Mounting foot         | 6 Foil key pad   |
| 3 7-segment display     | 7 Control system |
| 4 Housing cover bracket |                  |

### 6.4 Symbols on the device

#### 6.4.1 Warning stickers

The exemplary warning notices must be attached to the motor near the motor terminal board.

Warning sign	Description
	Warning of electrical voltage
	Read the instructions and follow the safety instructions
	Pull out the mains plug before opening

## 6.4.2 Type plate

Example

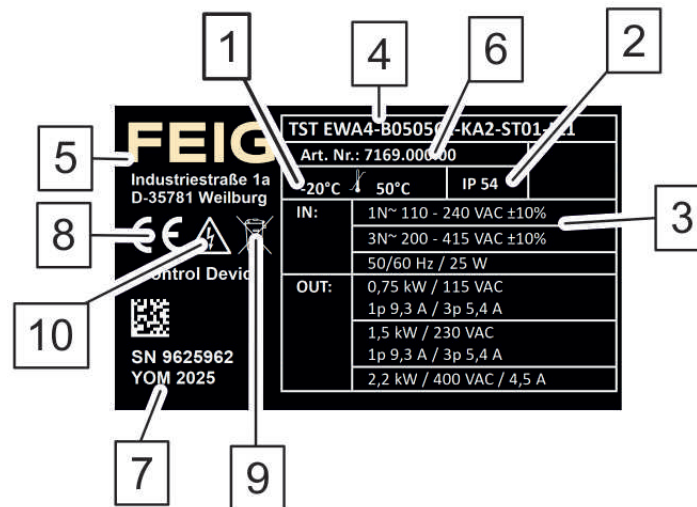







---

1	Temperature range	6	Serial number
2	Degree of protection	7	Year of manufacture
3	Operating voltage/electrical power	8	CE labelling
4	Product name and product variant	9	WEEE labelling of waste electrical and electronic equipment
5	Name and address of the manufacturer	10	Warning of electrical voltage

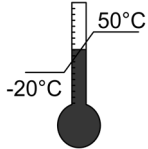
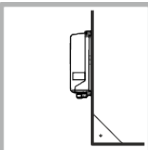
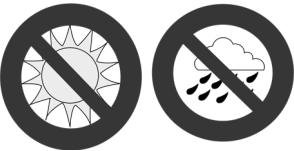
---

## 7 Installation

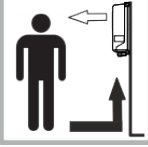
### 7.1 Selecting the installation location

	<p>The ambient temperature must be between -20 to +50 °C . Observe the information under "Technical data"! Observe the ventilation around the housing and the self-heating inside the housing!</p>
	<p>Fasten the door control unit to a low-vibration surface (e.g. solid masonry). Only install the unit in a vertical position.</p>
	<p>Ensure that the unit is not at risk of exposure to direct sunlight, rain or splash water when installed.</p>
	<p>Install the unit on a non-flammable substrate. Install the unit away from highly flammable substances.</p>
	<p>Ensure that there is no risk of electrostatic discharge to the unit when installed.</p>
	<p>Ensure that the unit is inaccessible to children when installed. The operating buttons should be located at a height of at least 1500 mm off the floor in accordance with the EN 60335 standard.</p>
	<p>The controls must be easily accessible and the display clearly visible.</p>

## 7.2 Installing the housing

### **⚠ WARNING**

#### **Damage to electronic parts!**

Electronic components are sensitive to electrostatic charge. Do not touch any electronic parts, in particular the components of the processor circuit.

- Only install the device when it is closed.

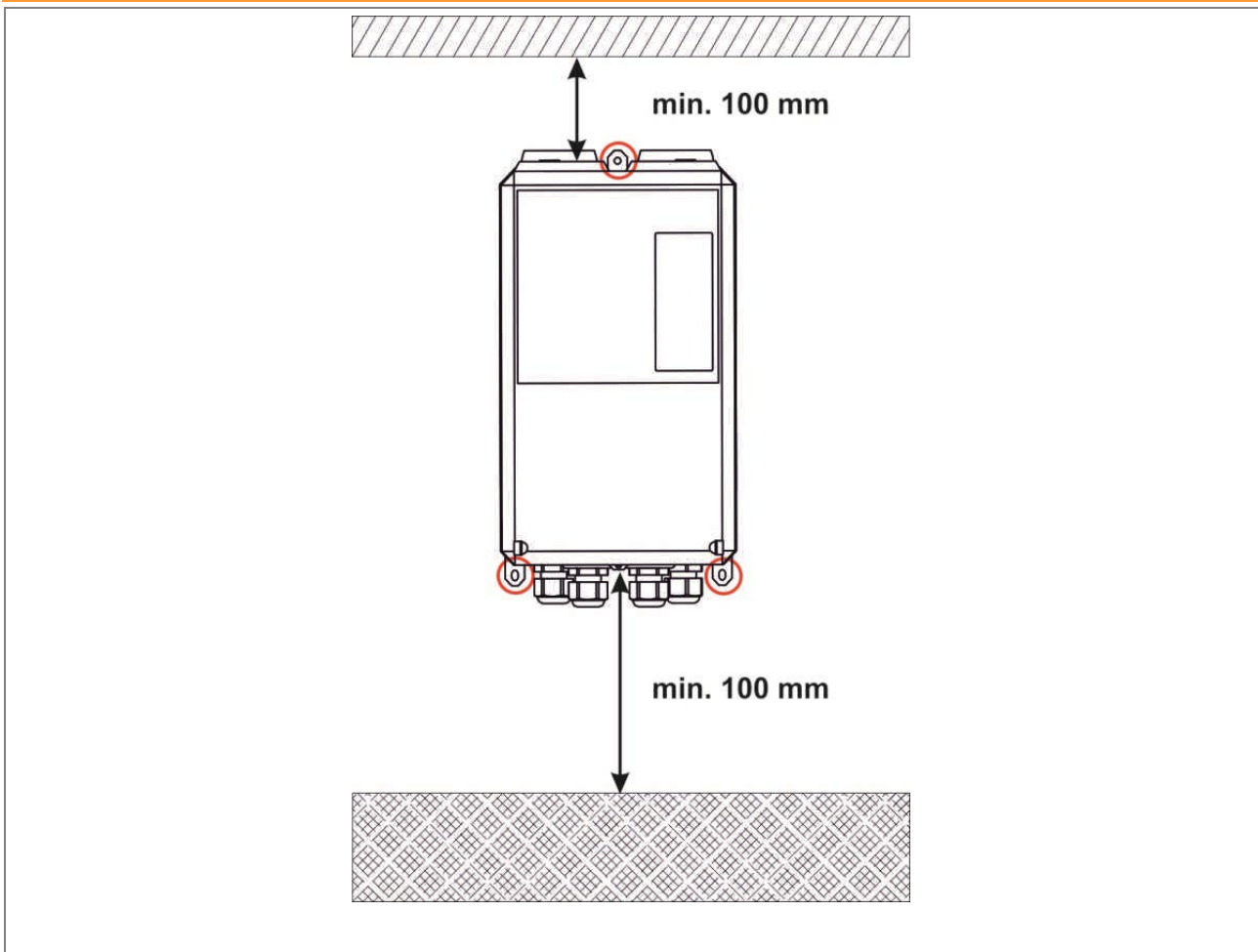

### 7.2.1 Drilling template for housing

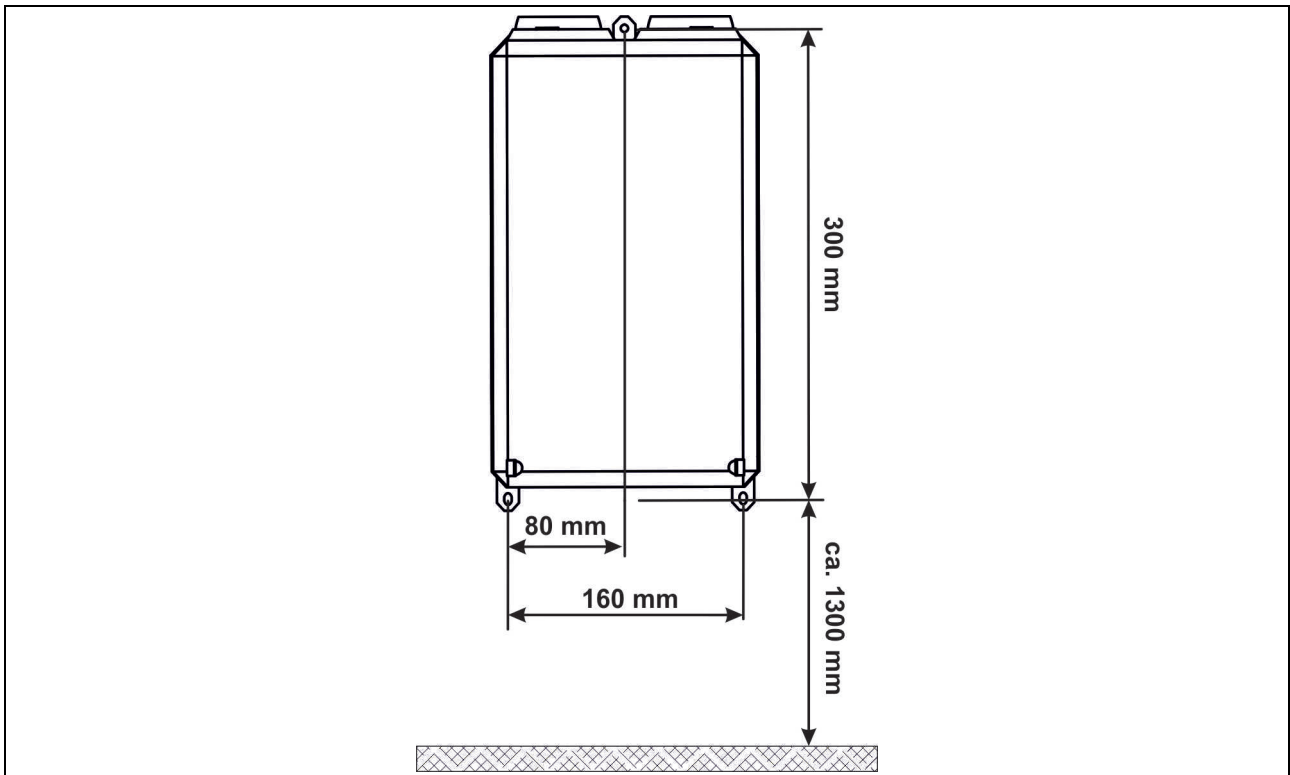

### 7.3 Opening the housing

#### **⚠ DANGER**

##### **Electrical voltage!**

Life-threatening danger from unprotected body parts or tools coming into contact with live components. The door control unit contains open, live parts.

Some components on the control board will still be live after the mains voltage is switched off.

Before opening the housing cover:

- > Always de-energise the door control unit.
- > Wait at least 4 minutes until the voltage has dissipated.
- > Secure the system to prevent it from being switched on again.

#### **⚠ WARNING**

Device protection!

Before opening the housing cover, make sure that there are no drilling chips or similar remnants on the housing cover.

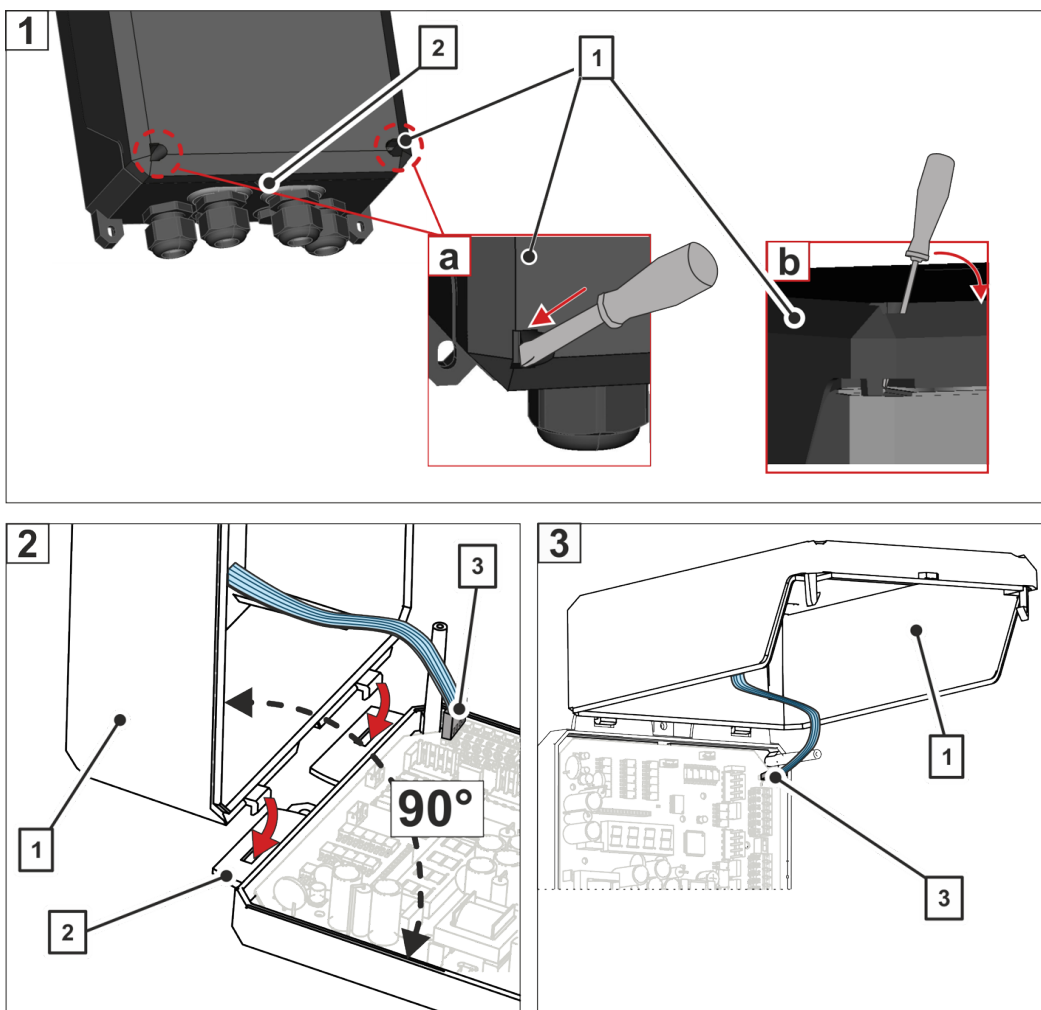

- 1 Housing cover
- 2 Housing bracket

- 3 Foil keypad connector

There are two openings on the left and right of the lower side of the housing cover. Using a suitable tool (recommendation: slotted screwdriver M5.5), the housing cover can be opened at these points.

1. Insert a slotted screwdriver into an opening. (Fig. 1a)  
The tip of the screwdriver must point with the flat side towards the left or right outside of the housing.
  2. Carefully press the handle of the screwdriver towards the housing cover. (Fig. 1b)  
The movement must be parallel to the bottom edge of the door control unit.
  3. Repeat steps 1 and 2 with the second opening.
  4. Fold the housing cover upwards at the cover flap.  
NOTE: The cover does not automatically remain open. The following steps must be carried out for further work on the door control unit.
  5. Lift the hinges of the housing cover out of the housing brackets.  
NOTE: Do not remove the connector for the foil keypad.
  6. Hang the housing cover at a 90-degree angle in the housing brackets until the hinges click into place. (Fig. 2)
- Housing is open.

## 7.4 Installing the motor cable

### NOTE

Only one motor with a maximum rated voltage of 400 V is permitted to be connected to the door control unit.

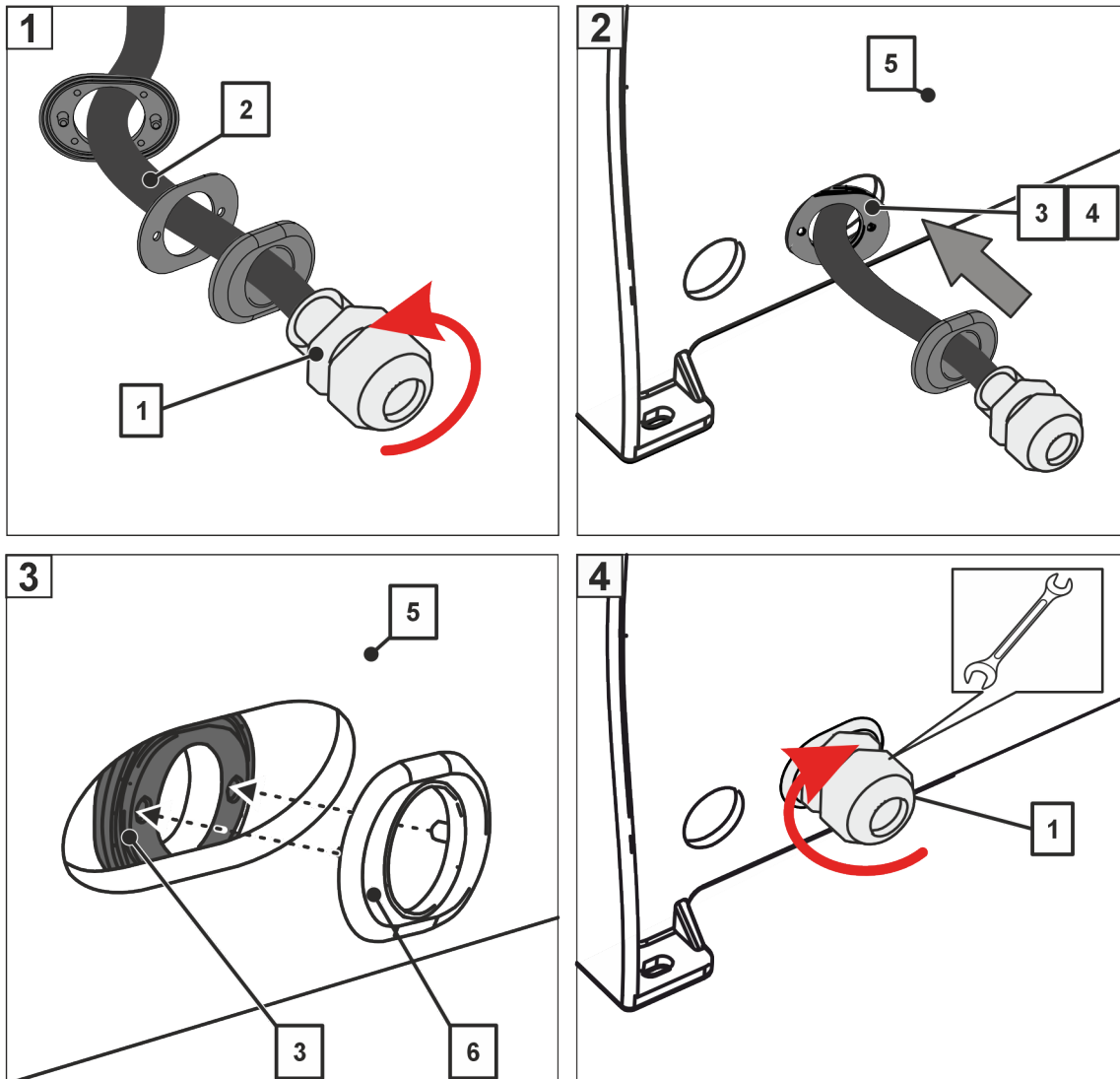

1	Cable gland	4	Sealing
2	Motor cable	5	Housing
3	Internal housing adapter	6	External housing adapter

1. Open the housing cover. (see "Opening the housing", page 29)
2. Loosen the screw connection.
3. Insert the motor cable with the internal housing adapter through the housing opening for the motor cable.
4. Press the internal housing adapter together with the external housing adapter at the housing.
5. Close the screw connection and tighten with an open-end spanner.
  - The motor cable is fitted.

The electrical connections must be implemented as described in the chapter see "Connecting the motor cable (three-phase motor with three-phase mains connection)", page 36.



## 8 Main connections

### 8.1 Connection diameters for the terminals on printed circuit boards

Connection	Single-wire (rigid)	Fine wire (with/without wire end ferrule)	Max. tightening torque [Nm]
Motor terminals	2.5	2.5	0.5
Mains connection	2.5	2,2	0.5
Screw terminals (grid 5 mm)	2.5	1.5	0.5
Plug-in terminals (grid 5 mm)	1.5	1.0	0.4
Plug-in terminals (grid 3.5 mm)	1.5	1.0	0.25

## 8.2 Overview of main connections

### **⚠ DANGER**

#### **Electrical voltage!**

Life-threatening danger from unprotected body parts or tools coming into contact with live components. The door control unit contains open, live parts.

Some components on the control board will still be live after the mains voltage is switched off.

Before accessing the connection terminals:

- > Always de-energise the door control unit.
- > Wait at least 4 minutes until the voltage has dissipated.
- > Secure the system to prevent it from being switched on again.

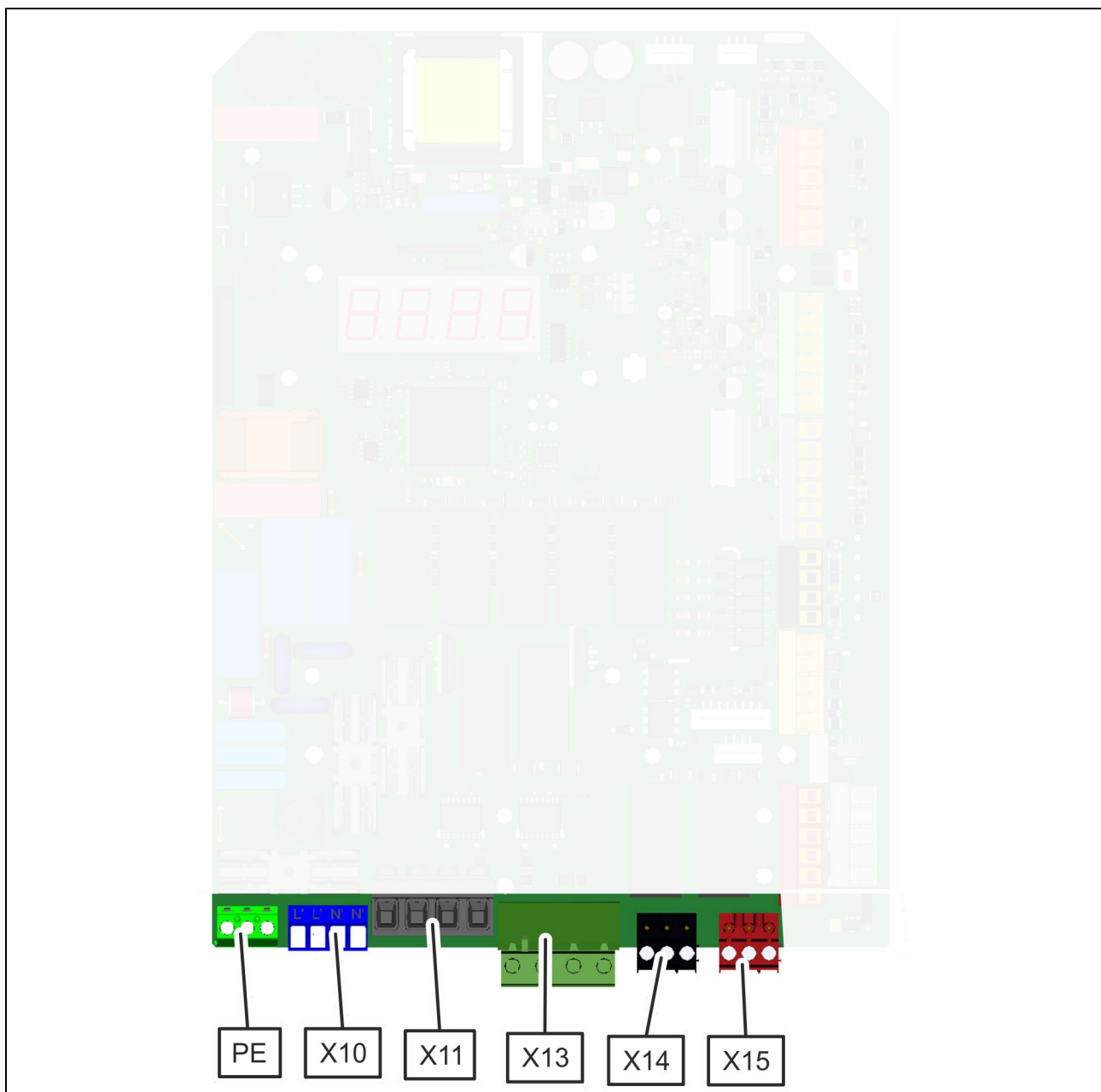

Block	Terminal, Connection/Naming	
X10	L' – Outer conductor L' – Outer conductor N' – Neutral conductor N' – Neutral conductor	Output
X11	Mains connection 1 – L1 2 – L2 3 – L3 4 – N	Input
PE	Protective earth conductor	
X13	Motor connection 1 – N 2 – T1 3 – T2 4 – T3	Output
X14	10 – K1 normally open, NO 11 – K1 Com 12 – K1 normally closed, NC	Output
X15	20 – K2 normally open, NO 21 – K2 Com 22 – K2 normally closed, NC	Output

### 8.2.1 Connecting the motor cable (three-phase motor with three-phase mains connection)

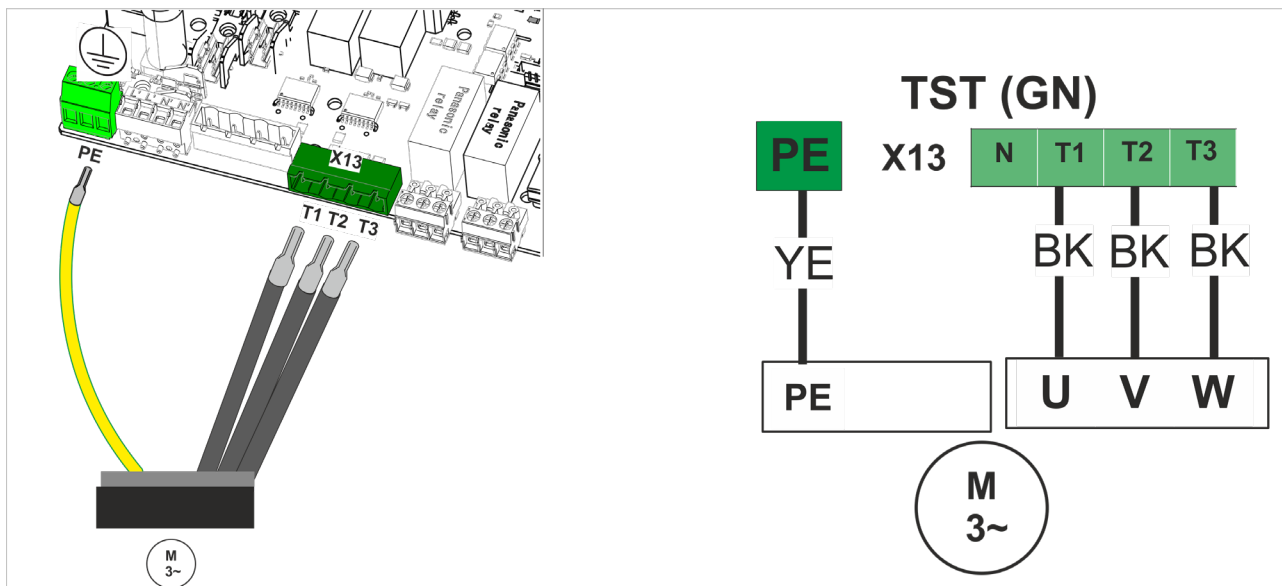

#### Prerequisites:

The door control unit housing is open. (see "Opening the housing", page 29)

1. Connect the wires for the motor cable to terminal X13.
  2. Connect the protective earth conductor to the PE terminal.
- The motor cable is connected.

## 8.2.2 Connecting the brake

### ATTENTION

In the case of drive units with an electronic brake, ensure that the brake is equipped with adequate suppression. We recommend the use of RC-elements for interference suppression purposes.

### ATTENTION

Terminals can be damaged.

There are springs in the terminals that ensure secure contact with the pin headers.

→ To connect the cables, always disconnect the terminals on the door control unit.

→ Once the cables are connected, plug the terminals into the door control unit in the starting position.

### 8.2.2.1 Connect brake via relay

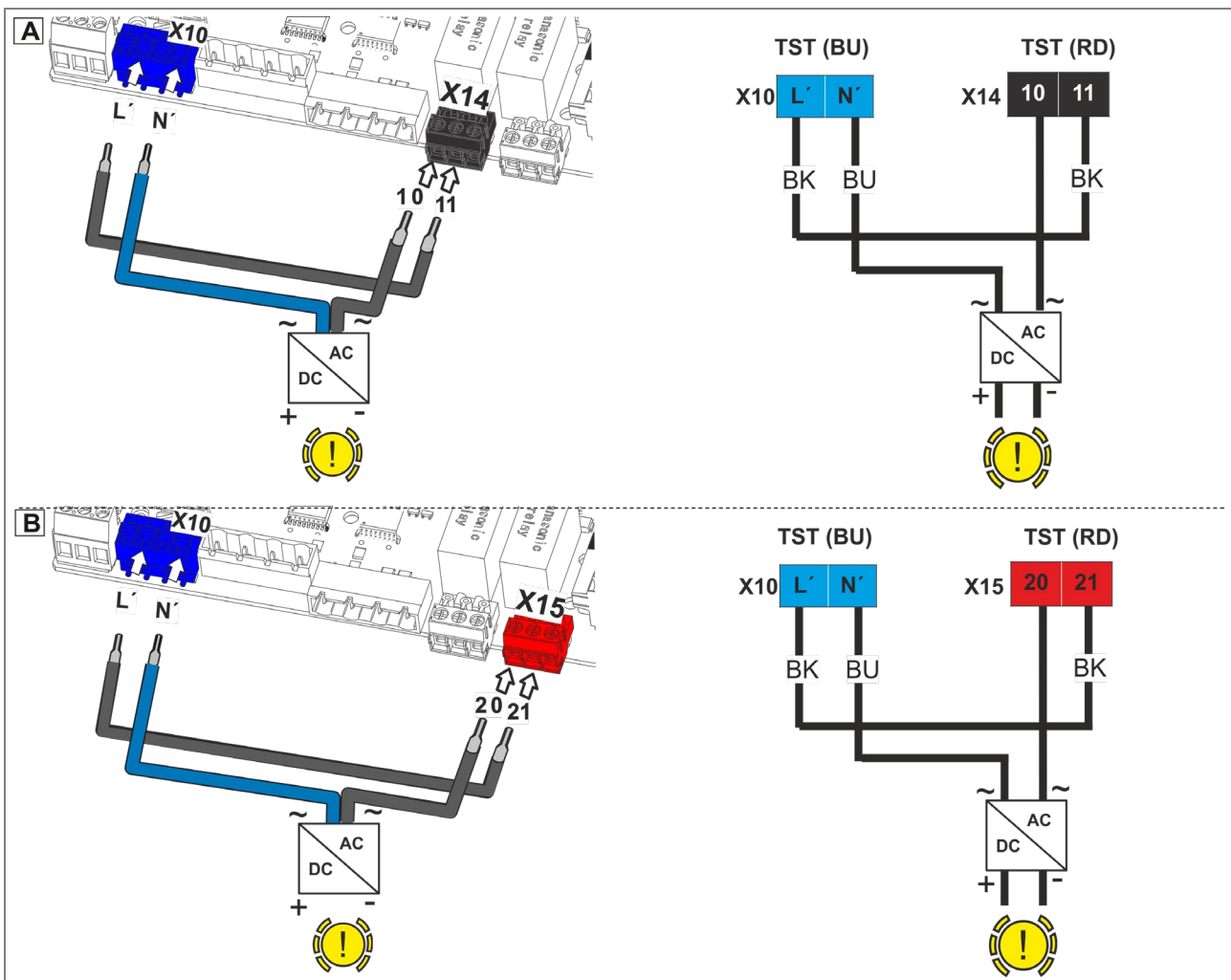

Prerequisites:

The door control unit housing is open. (see "Opening the housing", page 29)

The brake can be connected to either terminal X14 (Fig. A) or X15 (Fig. B).

1. Connect the wires of the brake rectifier to terminal X10 (N') and X14 (10).
2. Bridge terminals X10 (L) and X14 (11).

Alternatively, connect the brake to terminal X15 (Fig. B):

1. Connect the wires of the brake rectifier to terminal X10 (N') and X15 (20).
  2. Bridge terminals X10 (L) and X15 (21).
- The brake is connected.

### 8.2.2.2 Connecting the brake via the motor phase

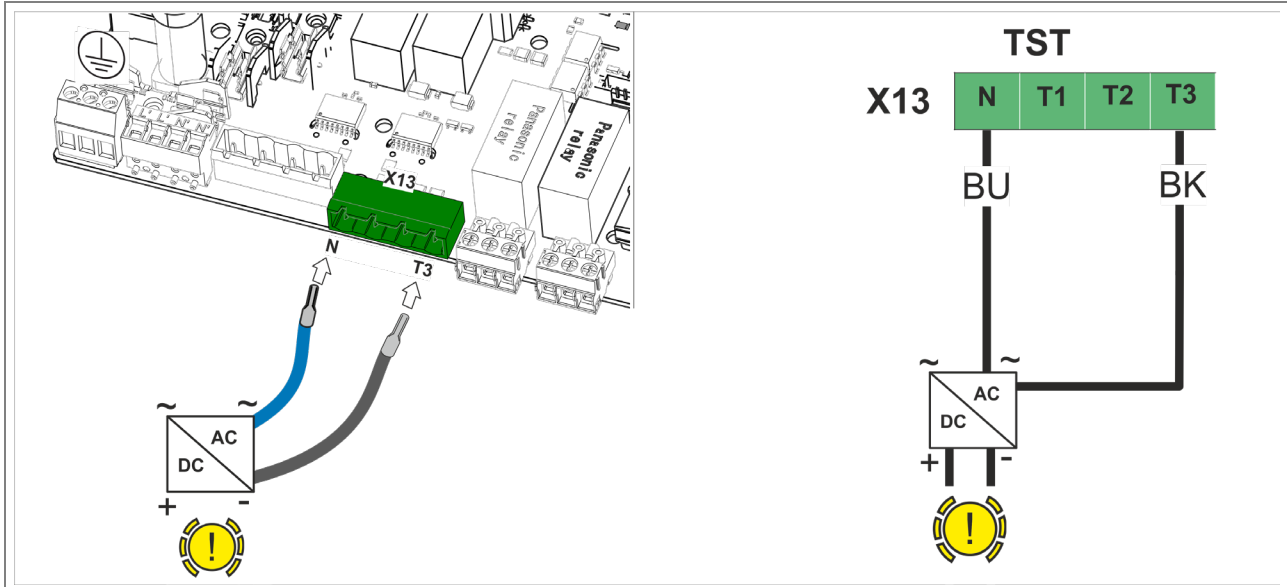

Prerequisites:

The door control unit housing is open. (see "Opening the housing", page 29)

1. Connect the wires of the brake rectifier to terminal PE and X13 (N and T3).
- The brake is connected.

## 9 Accessories for electrical connections

### 9.1 Accessories overview

#### ATTENTION

The following components are essential for safe operation:

- Limit switch system (electronic or mechanical)

A limit switch must be connected to set the door limit positions. The connection of the limit switch is described in the relevant instructions.

- Safety device (safety edge, photoeye or light curtain)

Depending on the door and its intended use, a protection device must be connected. The connection of the light curtain is described in the relevant instructions.

Optional connections as required:

- Traffic light
- External switches or buttons
- Radio receiver
- Induction loop detector
- Safety edge monitor
- Expansion boards
- Auxiliary relay
- Plain text display



All information on the respective accessories can be found in the corresponding instructions.

**DANGER**

**Electrical voltage!**

Life-threatening danger from unprotected body parts or tools coming into contact with live components. The door control unit contains open, live parts.

Some components on the control board will still be live after the mains voltage is switched off.

Before accessing the connection terminals:

- > Always de-energise the door control unit.
- > Wait at least 4 minutes until the voltage has dissipated.
- > Secure the system to prevent it from being switched on again.

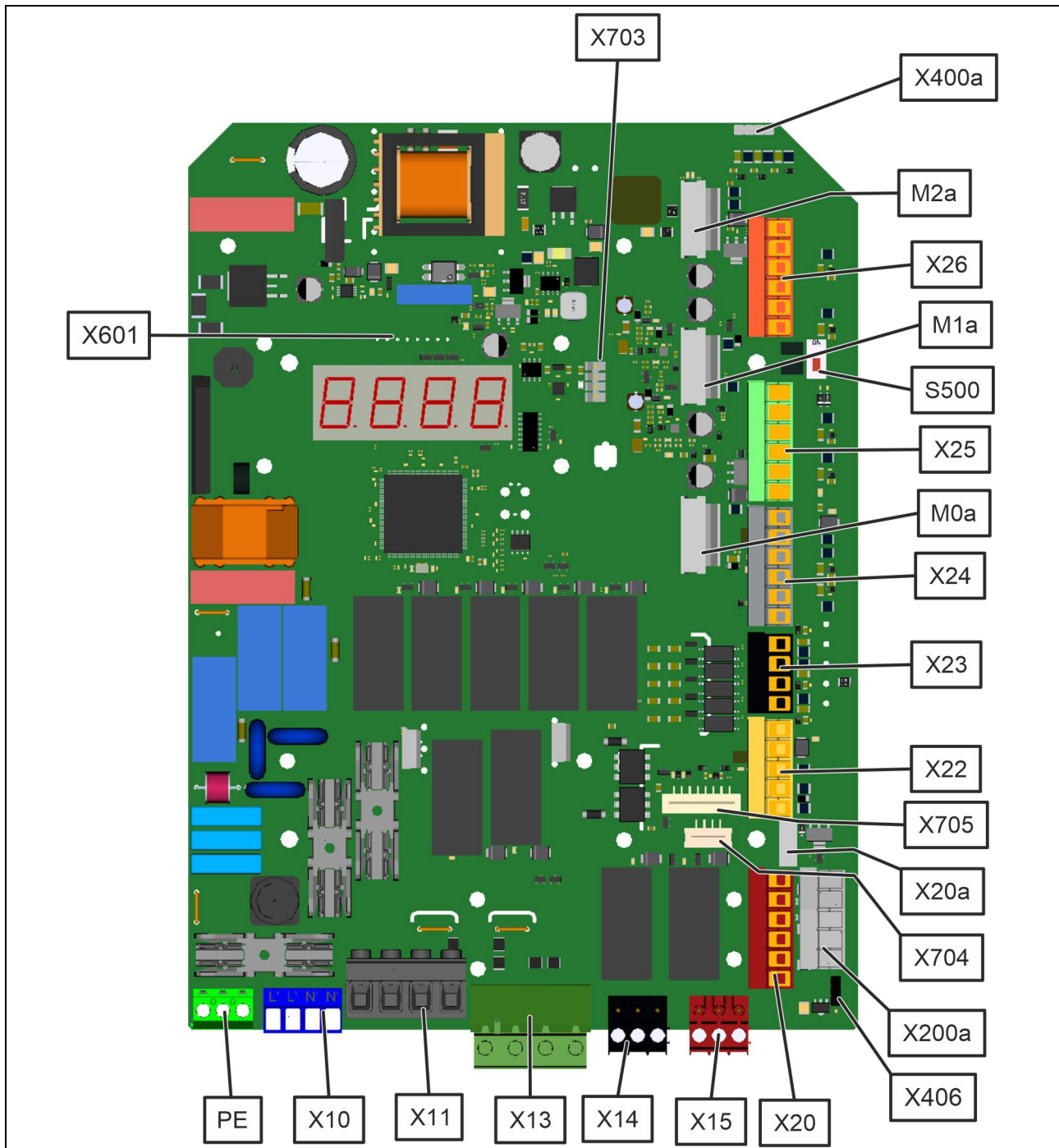

Block	Terminal, Connection/Naming
PE	Protective earth conductor
X10	L' – Outer conductor L` – Outer conductor N' – Neutral conductor N` – Neutral conductor
X11	Power supply L-N 110 to 400 VAC 1 – L1 2 – L2 3 – L3 4 – N
X13	Motor connection 1 – N 2 – T1 3 – T2 4 – T3
X14	Output 1 10 – NO 11 – COM 12 – NC
X15	Output 2 20 – NO 21 – COM 22 – NC
X20	36* – GND 35* – Channel B 34* – Channel A 33* – +24 V/+12 V 32* – Emergency stop 2 31* – Emergency stop 2
X20a	Connection for TST RFUxIO
X22	45 – +24 V 44 – GND 43 – Safety edge 42 – Emergency stop 1 41 – Emergency stop 1
X23	54 – Input 3 53 – Input 2 52 – Input 1 51 – +24 V

Block	Terminal, Connection/Naming
X24	66 – Output 15 65 – Input 10 64 – Input 9 63 – GND 62 – +24 V 61 – Input 8
X25	76 – +24 V 75 – Input 5 74 – GND 73 – +24 V 72 – Input 4 71 – GND
X26	86 – +24 V 85 – Input 7 84 – GND 83 – +24 V 82 – Input 6 81 – GND
X200a	CAN connection 5 – SH 4 – GND 3 – CANL 2 – CANH 1 – +24 V
X400a	Foil key pad connection
X406	Slot for jumper of external encoder
X601	Slot for plain text display
X703	Connection for TST RBA
X704	Connection for TST RFUxFCOM
X705	Connection for TST RFUxFCOM
M0a	Slot for expansion board
M1a	Slot for expansion board
M2a	Slot for expansion board
S500	DIP switch ON/OFF

### 9.2 Terminal description

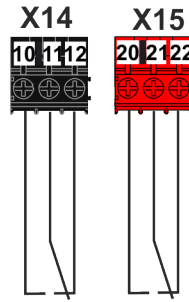

Block	Terminal	Connection/naming
X14	10	K1 NO
	11	K1 COM
	12	K1 NC

Block	Terminal	Connection/naming
X15	20	K2 NO
	21	K2 COM
	22	K2 NC

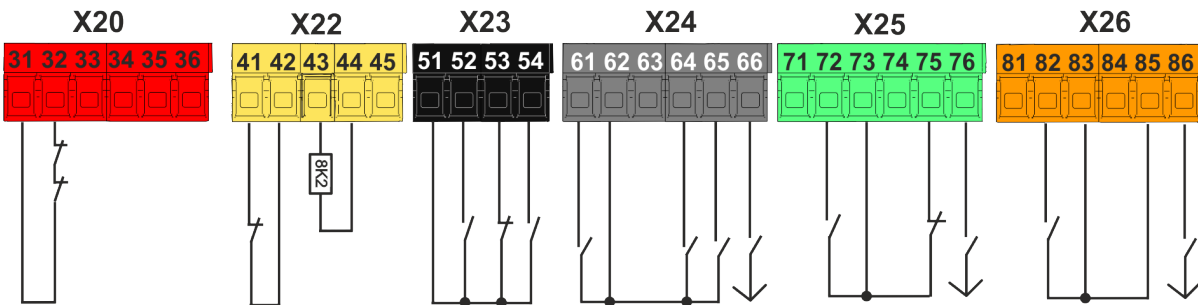

Block	Terminal	Connection/naming
X20	31	Emergency stop 2
	32	Emergency stop 2
	33	+24 V/+12 V
	34	A
	35	B
	36	GND
X22	41	Emergency stop 1
	42	Emergency stop 1
	43	Safety edge CLOSE travel
	44	GND
	45	+24 V
X23	51	+24 V
	52	Input 1 – OPEN
	53	Input 2 – STOP
	54	Input 3 – CLOSE

Block	Terminal	Connection/naming
X24	61	Input 8 – locked in limit position CLOSE
	62	+24 V
	63	GND
	64	Input 9 – cross traffic
	65	Input 10: Safety edge 2: For electrical safety edges with 8.2/1.2 kΩ termination resistor and for dynamic optical systems (Fraba) alternative operation as digital control input
	66	OUT 15: +24 V
X25	71	GND
	72	Input 4 – pull switch (open/close)
	73	+24 V
	74	GND
	75	Input 5 – photoeye
	76	+24 V

X26	81	GND
	82	Input 6 – constantly open
	83	+ 24 V
	84	GND
	85	Input 7 – manual/automatic
	86	+24 V

### 9.3 Connecting different limit switch systems

Different limit switch systems can be used with the **TST EWA4-B0505** door controller. Both position encoders and mechanical limit switches (cam limit switches) can be connected.

**NOTE**

- The use of a limit switch is mandatory as a safety device.
- The connection of the position encoder is described in the respective accessory manual.

#### Connecting the mechanical cam-operated limit switch



**Electrical voltage!**

Life-threatening danger from unprotected body parts or tools coming into contact with live components. The door control unit contains open, live parts.

Some components on the control board will still be live after the mains voltage is switched off.

Before accessing the connection terminals:

- > Always de-energise the door control unit.
- > Wait at least 4 minutes until the voltage has dissipated.
- > Secure the system to prevent it from being switched on again.

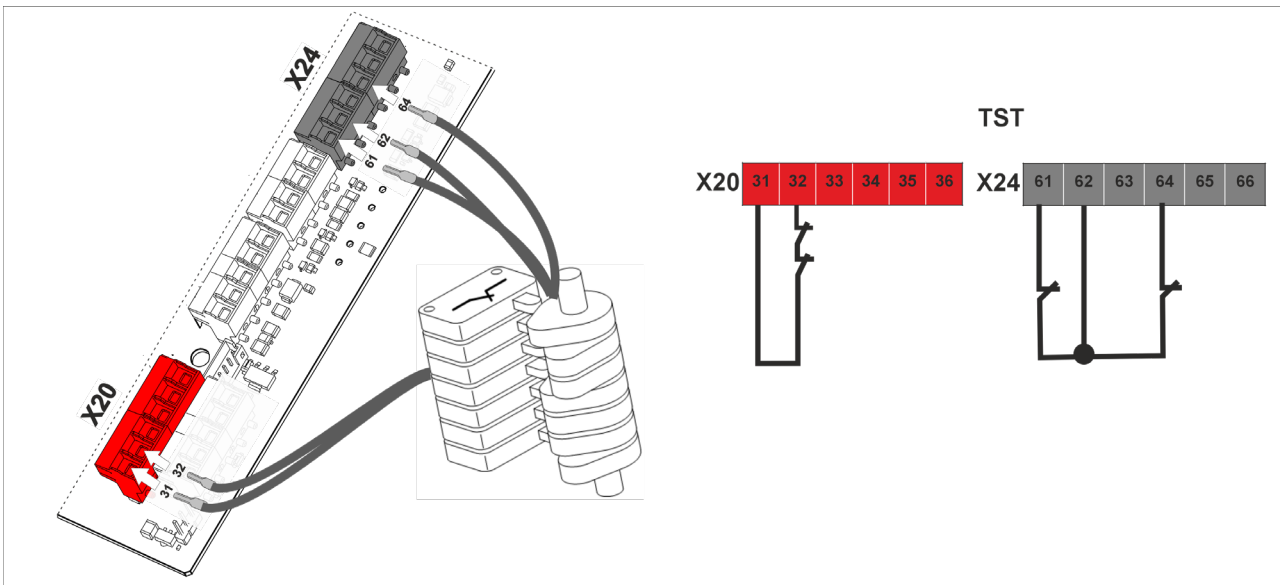

Block	Terminal	Connection/naming
X20	31	Emergency stop
	32	Crank switch Thermo switch Emergency limit switch OPEN Emergency limit switch CLOSED

Block	Terminal	Connection/naming
X24	61	Input 8 – limit switch door OPEN
	62	+24 V
	64	Input 9 – limit switch door CLOSED

## 9.4 Connect the safety edge

The safety edge evaluator enables the evaluation of electrical safety edges with a terminating resistance of 8.2 kOhm or 1.2 kOhm, or of dynamic optical systems.

Two safety edge evaluators are integrated on the control board.



*If more than two safety edges are required, the TST SURA 6 plug-in module must be plugged in.*

The following types of safety edges can be connected to the control unit:

### at the first evaluator

- Electrical safety edge with a termination resistor of 8.2 kOhm or 1.2 kOhm
- Dynamic optical systems

### at the second evaluator

- Electrical safety edge with a termination resistor of either 1.2 kOhm or 8.2 kOhm
- Dynamic optical systems
- Digital input
- Escape door/slack rope switch with 8.2 kΩ termination resistor

If you want to connect a different safety edge, ask the door manufacturer.

### NOTE

If no safety edge is connected to the first evaluator, the following must be taken into account:

- Door can only be closed manually using the foil keypad. Automatic CLOSE travel is not possible.
- Safety edge evaluator must be deactivated via the parameter settings.

### DANGER

#### Electrical voltage!

Life-threatening danger from unprotected body parts or tools coming into contact with live components. The door control unit contains open, live parts.

Some components on the control board will still be live after the mains voltage is switched off.

Before accessing the connection terminals:

- > Always de-energise the door control unit.
- > Wait at least 4 minutes until the voltage has dissipated.
- > Secure the system to prevent it from being switched on again.

### ATTENTION

Terminals can be damaged.

There are springs in the terminals that ensure secure contact with the pin headers.

- To connect the cables, always disconnect the terminals on the door control unit.
- Once the cables are connected, plug the terminals into the door control unit in the starting position.

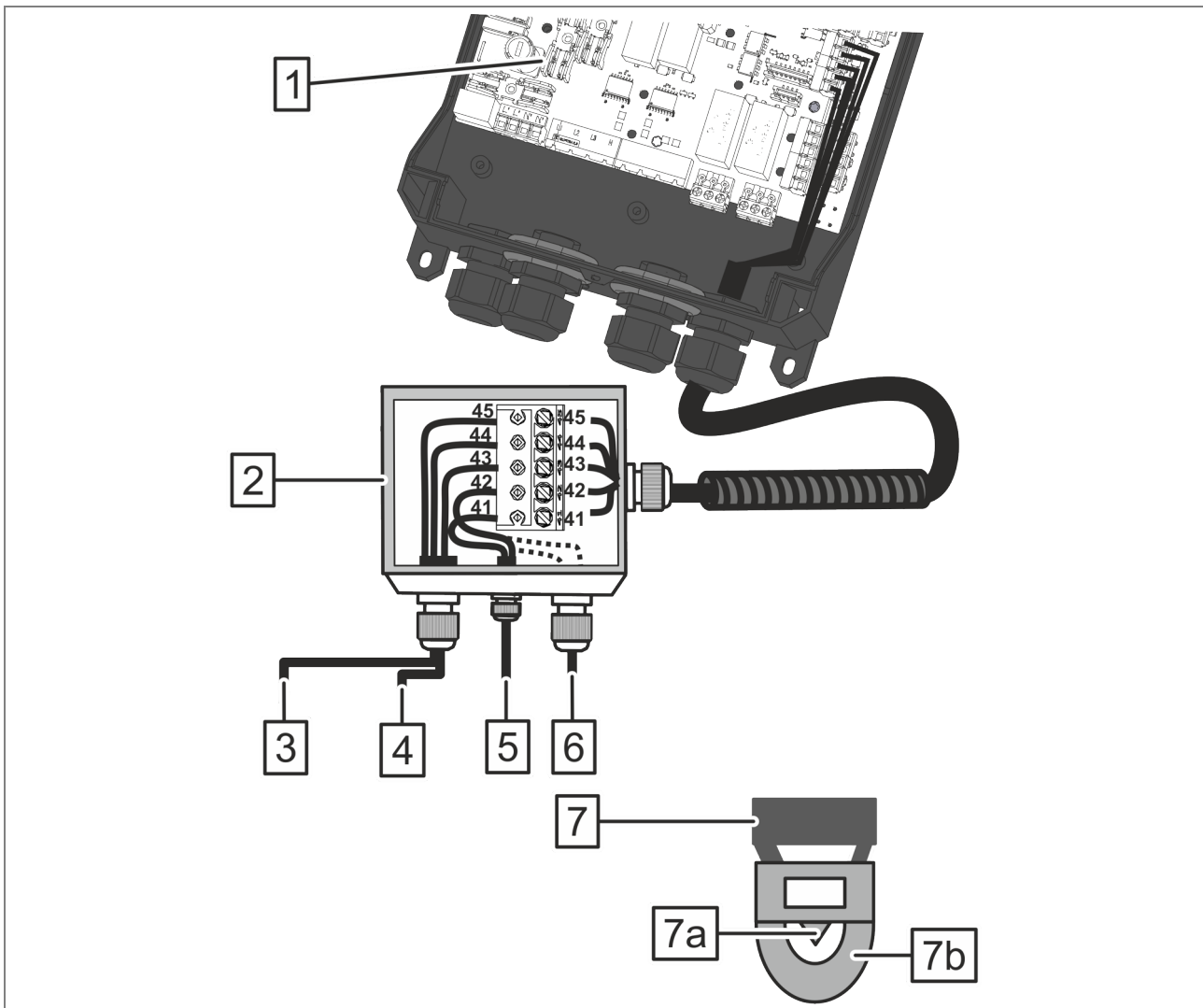

1	Control system	(TST)	6	Optional escape door switch	(SW-SD)
2	Door leaf junction box	(KB)	7	Cross-section of safety edge	(SE)
3	Receiver	(RX)	7a	Safety edge (inside)	(SL)
4	Transmitter	(TX)	7b	Safety edge (outside)	(SL)
5	Slack rope switch	(SW-SR)			

### 9.4.1 Connect the safety edge to the first evaluator

#### 9.4.1.1 Connecting the electrical safety edge

**NOTE**

The door control unit is set at the factory so that a safety edge must be connected. If no safety edge has been connected or if a safety edge has been connected incorrectly, an error message (F.369) appears on the display. A subsequently connected safety edge can then be activated manually via the parameter settings. For an electrical safety edge, parameter P.460 must be set to value 1 or 2 (normally open or normally closed contact).

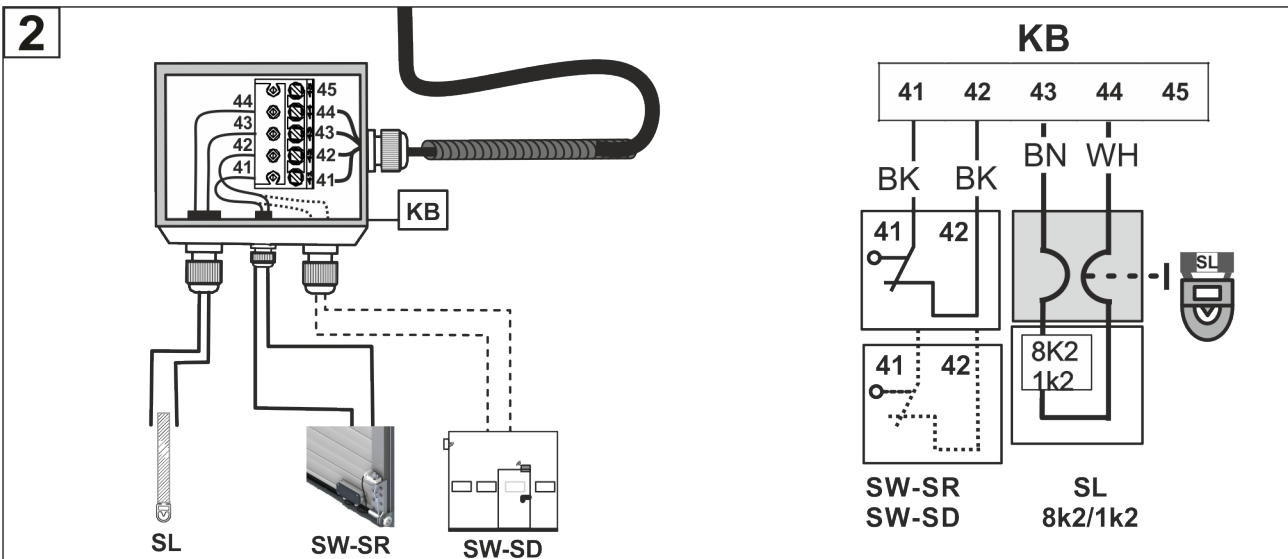
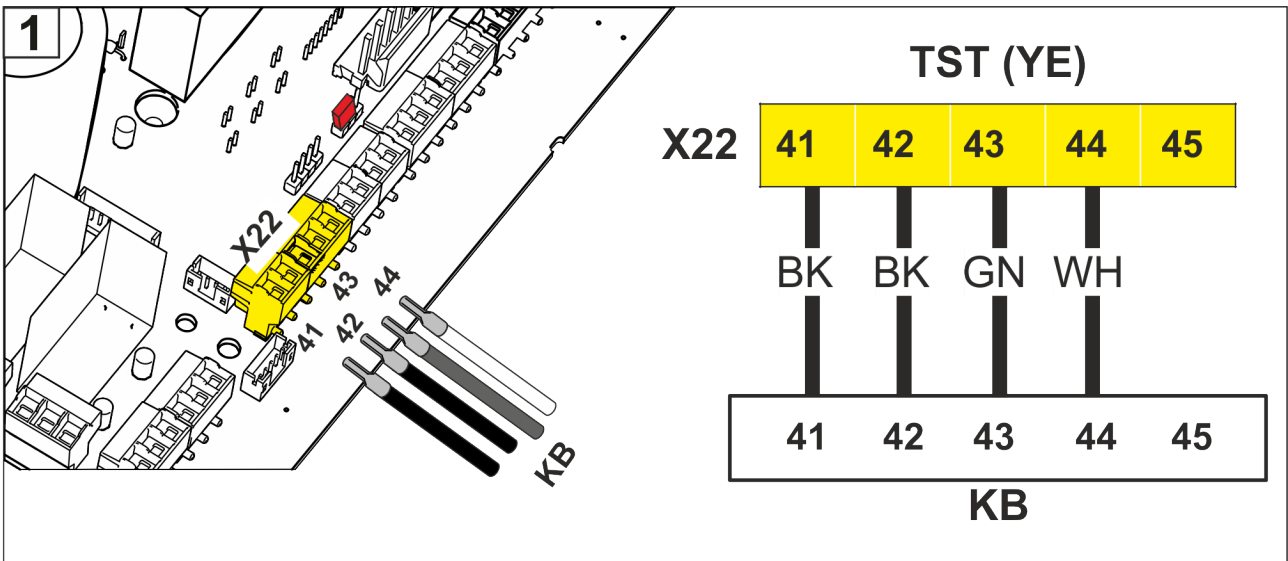

**Prerequisites:**

The door control unit housing is open. (see "Opening the housing", page 29)

1. Connect the wires of the door leaf terminal box to terminal X22 of the control unit.
  2. Connect the terminal box to the safety edge and the escape door switch (optional).
- Electrical safety edge is connected and linked to the evaluator.

As soon as the door control unit is switched on, the safety edge is automatically detected and activated.

### 9.4.1.2 Connecting the dynamic optical safety edge

#### NOTE

The door control unit is set at the factory so that a safety edge must be connected. If no safety edge has been connected or if a safety edge has been connected incorrectly, an error message (F.369) appears on the display. A subsequently connected safety edge can then be activated manually via the parameter settings. For a dynamic optical safety edge, parameter P.460 must be set to value 5.

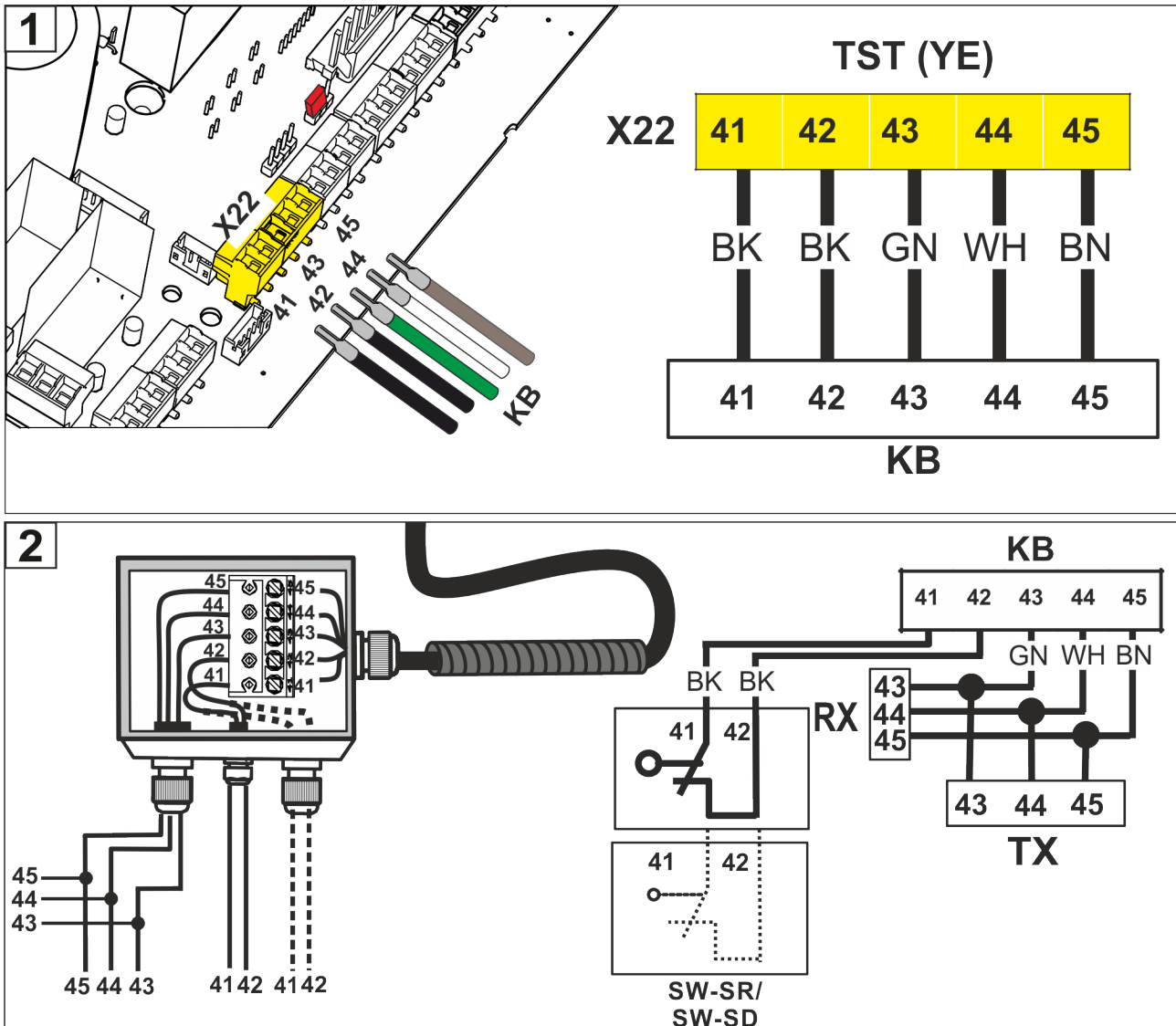

#### Prerequisites:

The door control unit housing is open. (see "Opening the housing", page 29)

1. Connect the wires of the door leaf terminal box to terminal X22 of the control unit.
2. Connect the terminal box to the safety edge and the escape door switch (optional).

➤ Dynamic optical safety edge is connected and linked to the evaluator.

As soon as the door control unit is switched on, the safety edge is automatically detected and activated.

## 9.4.2 Connecting the second safety edge to the second evaluator

### NOTE

A second safety edge only needs to be connected if required.

The evaluator connection is deactivated ex works if no safety edge is connected.

### 9.4.2.1 Connecting the electrical safety edge

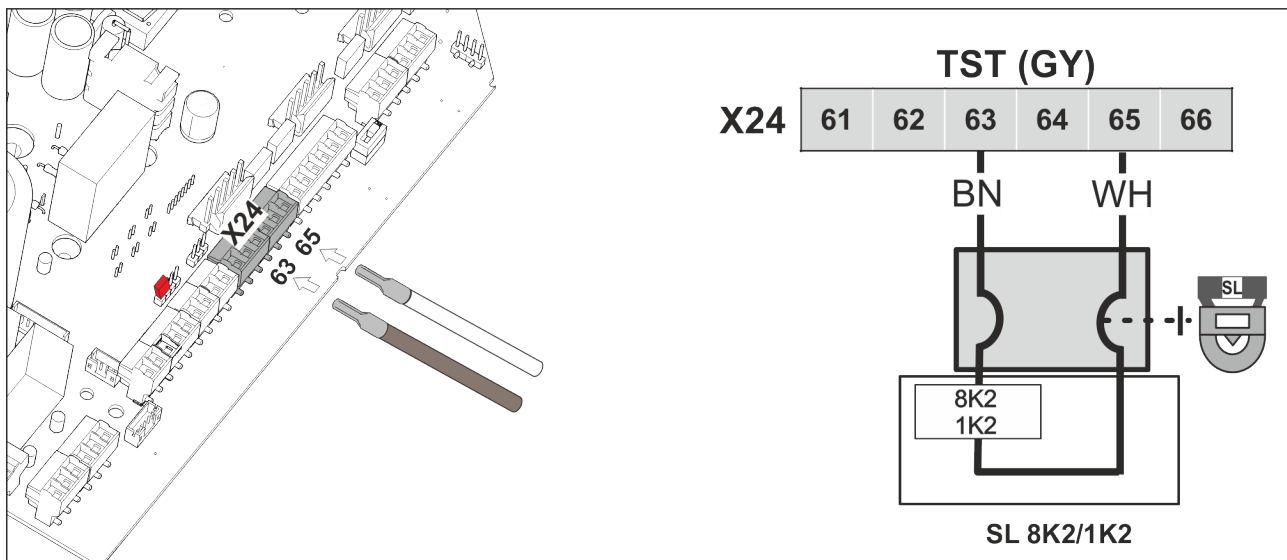

#### Prerequisites:

The door control unit housing is open. (see "Opening the housing", page 29)

- Connect the wires of the door leaf terminal box to terminal X24 of the control unit.
- Electrical safety edge is connected and linked to the evaluator.

The safety edge must then be activated via the parameter settings: Set parameter P.5A2 to value 2 or 3 (normally open or normally closed contact).

### 9.4.2.2 Connecting the dynamic optical safety edge

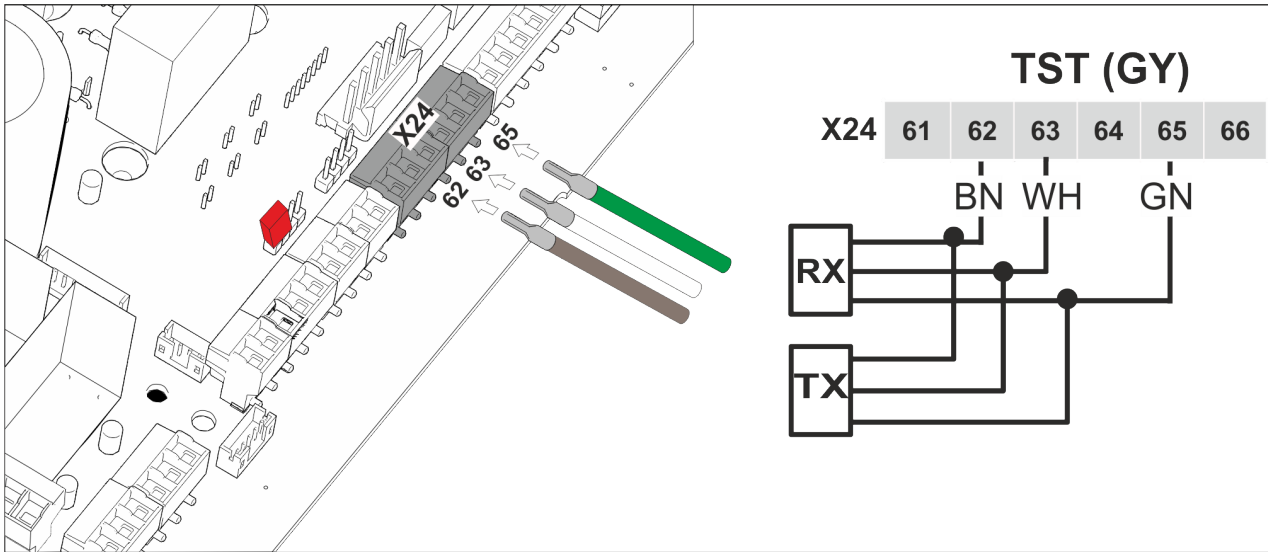

#### Prerequisites:

The door control unit housing is open. (see "Opening the housing", page 29)

- Connect the wires from the transmitter and receiver to terminal X24 of the door control unit.
- Dynamic optical safety edge is connected and linked to the evaluator.

The safety edge must then be activated via the parameter settings: Set parameter P.5A2 to value 4.

### 9.4.2.3 Connecting the digital input

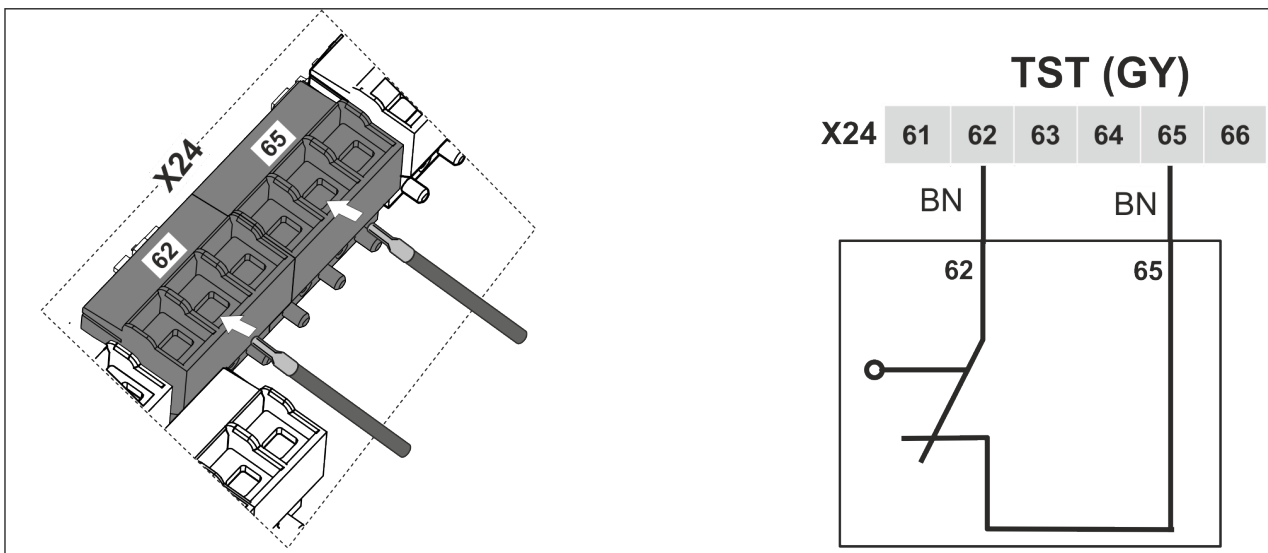

#### Prerequisites:

The door control unit housing is open. (see "Opening the housing", page 29)

- Connect the wires of the switch to terminal X24 of the door control unit.
- Digital input is connected and linked to the evaluator.

The digital input must then be activated via the parameter settings: Set parameter P.5A2 to value 0, 1 or 8.

### 9.4.2.4 Connecting the slack rope/escape door switch

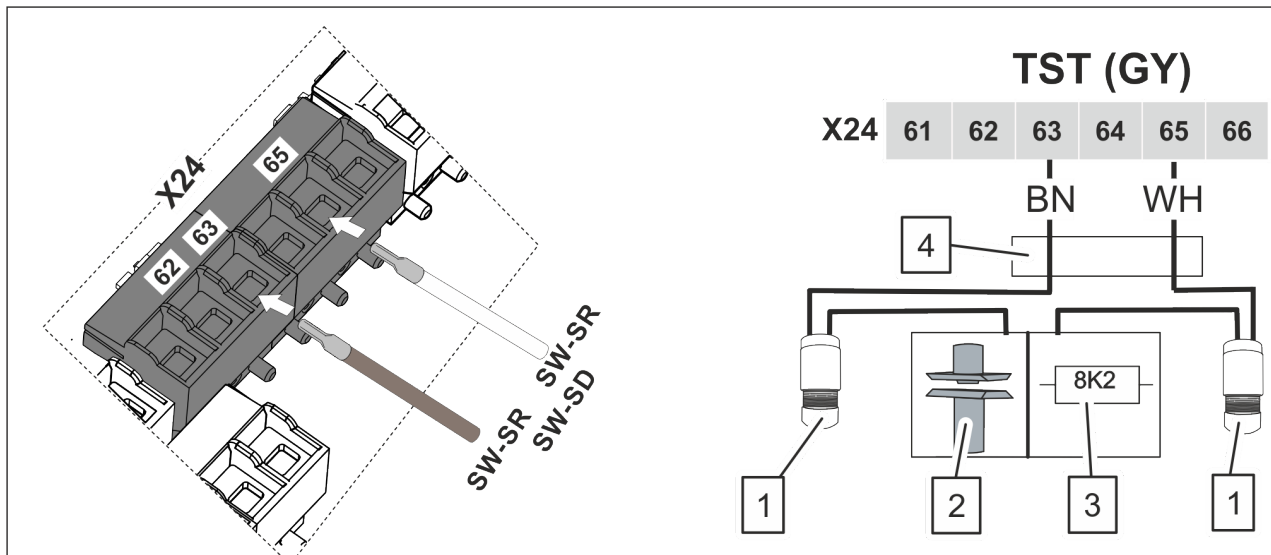

- |   |                                     |   |                                    |
|---|-------------------------------------|---|------------------------------------|
| 1 | Slack rope switch (SW-SR)           | 3 | Resistor 8K2                       |
| 2 | Optional escape door switch (SW-SD) | 4 | Door leaf junction box (schematic) |

## Prerequisites:

The door control unit housing is open. (see "Opening the housing", page 29)

**ATTENTION**

- Lay unprotected cables to the slack rope switches in protective conduits or protective hoses.
- Lay the cable in the door leaf.

1. Connect both slack rope switches to terminal X24 of the door control unit.
  2. Connect the slack rope switch to an escape door switch (optional). If there is no escape door, connect a resistor 8K2.
- The slack rope/escape door switch is connected and linked to the evaluator.

## 9.5 Connecting the photoeye

### **DANGER**

#### Electrical voltage!

Life-threatening danger from unprotected body parts or tools coming into contact with live components. The door control unit contains open, live parts.

Some components on the control board will still be live after the mains voltage is switched off.

Before accessing the connection terminals:

- > Always de-energise the door control unit.
- > Wait at least 4 minutes until the voltage has dissipated.
- > Secure the system to prevent it from being switched on again.

### **ATTENTION**

Terminals can be damaged.

There are springs in the terminals that ensure secure contact with the pin headers.

- To connect the cables, always disconnect the terminals on the door control unit.
- Once the cables are connected, plug the terminals into the door control unit in the starting position.



Block	Terminal, Connection/Naming
X25	76 – +24 V
	75 – Input 5
	74 – GND

- Connect the wires of the photoeye to terminal X25 of the control unit.

## 10 Operation

### 10.1 Switch door control on/off

**NOTE**

**Wiring test when switching on the door control unit**



After the door control unit has been configured for the first time, each time the door control unit is switched on, 3 "click" sounds will be played and `Self Check` will appear on the display (plain text display). This checks whether the relays are switched on and which motor type is connected.

The door control unit does not have an on/off switch. It starts automatically as soon as the mains plug is connected to the power supply.

### 10.2 Keypad commands

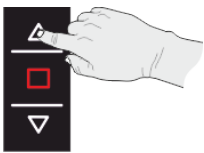
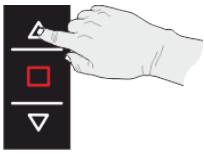
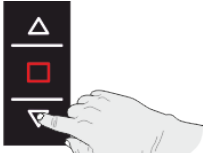
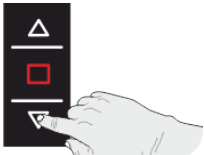
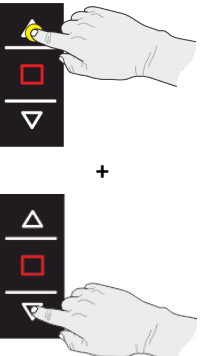
The keypad is used to manually control the door movements and to set the parameters.

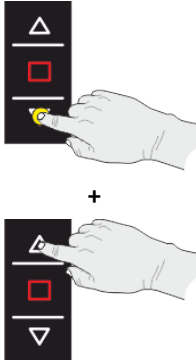
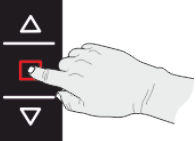
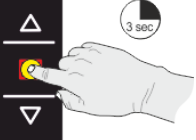
Symbol	Action/button	Description
	Press OPEN/UP briefly	<ul style="list-style-type: none"> <li>• Open door/barrier</li> <li>• Navigate through parameter menu</li> <li>• Increase parameter value</li> </ul>
	Press and hold OPEN/UP	<ul style="list-style-type: none"> <li>• Increase parameter value more rapidly</li> </ul>
	Press CLOSE/DOWN briefly	<ul style="list-style-type: none"> <li>• Close door/barrier</li> <li>• Navigate through parameter menu</li> <li>• Decrease parameter value</li> </ul>
	Press and hold CLOSE/DOWN	<ul style="list-style-type: none"> <li>• Decrease parameter value more rapidly</li> </ul>
	Hold down the OPEN/UP button and incrementally press the CLOSE/DOWN button	<ul style="list-style-type: none"> <li>• Navigate to the next parameter group (upwards)</li> </ul>

	<p>Hold down the CLOSE/DOWN button and incrementally press the OPEN/UP button</p>	<ul style="list-style-type: none"> <li>• Navigate to the next parameter group (downwards)</li> </ul>
	<p>Press STOP briefly</p>	<ul style="list-style-type: none"> <li>• Stop door/barrier while in motion</li> <li>• Select/activate parameters</li> <li>• Discard parameter selection (i.e. do not save changes)</li> </ul>
	<p>Press and hold STOP for approx. 3 seconds</p>	<ul style="list-style-type: none"> <li>• Save door positions</li> <li>• Save parameter selection</li> <li>• Exit parameter setting mode</li> </ul>
	<p>Press and hold OPEN/UP and STOP simultaneously for approx. 3 seconds</p>	<ul style="list-style-type: none"> <li>• Initiate parameter setting mode</li> </ul>
	<p>Press and hold OPEN/UP, STOP and CLOSE/DOWN simultaneously for approx. 3 seconds</p>	<ul style="list-style-type: none"> <li>• Initiate restart</li> </ul>

### 10.3 Activating the DIP switch

To be able to implement advanced parameter settings at password level 1 and above, the DIP switch (S500) on the control board must be activated and set to ON.

#### **⚠ DANGER**

##### **Electrical voltage!**

Life-threatening danger from unprotected body parts or tools coming into contact with live components. The door control unit contains open, live contacts. Never make changes to the control board when it is switched on.

- Before making any changes to the DIP switch, always de-energise the device and secure it to prevent it from being switched on again.

#### **NOTE**

The DIP switch is preset to ON on delivery.

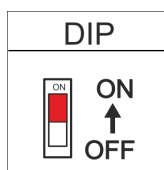

### 10.4 Initiating parameter setting mode

Parameter settings are initiated in 2 different ways.

This depends on the type of parameter:

- Basic settings (configured via automatic query during initial commissioning)
- All other parameters (manual selection)



*The access level determines which parameters are displayed and can also be changed. It is defined via the password level. The DIP switch can also be set to OFF for parameter settings that are visible and can be changed at access level 0. The DIP switch must be set to ON for changes at access level 1 and above. Certain function settings or customer-specific settings can only be viewed and changed with a higher access level.*

The manual parameter setting mode is initiated by pressing a combination of buttons.

**Prerequisite:**

- Control unit is switched on.

1. Press and hold both the OPEN/UP and STOP buttons simultaneously for 3 seconds.



↳ The display shows:

Indicator display	
7-segment	Plain text display
P . 0 0 0	P:Door cycles 000# 0 CYcl

➤ The parameter setting mode has been initiated.

### 10.5 Editing the parameter settings

**Prerequisites:**

The parameter setting mode has been initialised; a parameter is shown in the display.

Note: All parameters and values shown here are examples. The parameters and values that are actually displayed in each case will depend on the selected parameter.

- **Change parameter**

↳ Press the or button to navigate through the parameters and bring up the corresponding parameter.

- **Change the value of the parameter**



1. Briefly press the button.

↳ Navigate to the value  
The following appears on the display:

Indicator display	
7-segment	Plain text display
10	P:Auto Close 1 010= 10√s



On the 7-segment display, the set value is displayed; on the plain text display, the cursor moves under the set value and flashes.

2. Adjust the value using the  and  buttons.

Indicator display	
7-segment	Plain text display
1 . . 2	P:Auto Close 1 010= 1 <u>2</u> ?s



When the value is being entered/changed, one or more dots flash between the numbers on the 7-segment display; on the plain text display, a question mark flashes after the number.

• **Save value**

- ↶ Press and hold the  button for 3 seconds.
- The value is saved.
- The following appears on the display:

Indicator display	
7-segment	Plain text display
1 0	P:Auto Close 1 010= 10✓s

• **Discard value input/adjustment (i.e. do not save changes)**

- ↶ Briefly press the  button.
- The last saved value remains set.
- The following appears on the display:

Indicator display	
7-segment	Plain text display
0 5	P:Auto Close 1 010= 05✓s

• **Exit value input/adjustment**

- ↶ Briefly press the  button.

Indicator display	
7-segment	Plain text display
1 0	P:Auto Close 1 01 <u>0</u> = 10 s



On the plain text display, the cursor flashes under the parameter.

- The cursor is positioned on the parameter. A new parameter can be selected.

## 10.6 Exiting parameter setting mode

**Prerequisites:**

The parameter (e.g. P.010) is shown on the 7-segment display.

On the plain text display, the cursor is located on the parameter. (e.g. 010=)

Press and hold the  button for approx. 3 seconds.

- The parameter setting is exited immediately.
- Door operation is active.

**NOTE**

---

After approx. one hour, the password is automatically reset to 0. The position of the DIP switch is ignored and treated as switched off.

To return to the parameter settings, a restart must be initiated or the door control unit must be switched off and on again.

---

## 10.7 Initiating a restart

Press and hold all 3 buttons    simultaneously for approx. 3 seconds.

➤ The door control unit restarts.

## 10.8 Changing the access level

Various function-specific or customer-specific settings are only possible at the respective access level. Access to the respective access level is defined via a password.

All settings in these instructions can be made with passwords 0 to 2.

### ATTENTION

Damage to property!

Changes to the parameter settings made at access level 2 or above may result in serious damage to the door.

Changes to the settings with password 2 or above are only permitted to be carried out by trained specialist personnel.

### Prerequisites:



- DIP switch (S500) is set to ON.

Password 0 is preset ex works.

1. Press and hold the  and  buttons simultaneously for approx. 3 seconds.

↪ Parameter setting is active.

↪ The display shows:

2. Use the   buttons to select the parameter P. 999.

3. Briefly press the  button.

4. Enter the password for the access level using the  button.

Note: Select a value between 0–2.

5. Press and hold the  button for 3 seconds.

➤ Password level is saved.

Indicator display	
7-segment	Plain text display
P . 0 0 0	P:Door cycles 000# X CYcl
P . 9 9 9	P:Password 999=                    0000 #

## 11 Configure door control unit

### CAUTION

Risk of injury!

Before configuring the door control unit, it must be ensured that there are no persons or objects in the danger zone of the door. This is because certain settings will cause the door to move.

### 11.1 Basic settings

#### Overview of the required settings:

- Basic settings (**always** upon first commissioning or after the door control unit has been reset to the factory default)

Depending on the connected peripheral devices, additional settings may be required for:

- Brake
- Door limit positions
- Light curtain
- Traffic light indicator
- Plug-in modules and expansion boards (depending on the additional boards used)

#### NOTE

Check the electrical connections during initial commissioning!

When commissioning the door control unit for the first time, check that the electrical connections have all been implemented correctly and that the expansion boards and plug-in modules are positively connected to the connections.

Incorrect connections will produce messages during configuration of the door control unit and may result in damage to the control unit.

#### NOTE

Note the setting of the DIP switch!

The DIP switch (S500) must be set to ON in order to be able to set or change parameters. The switch is preset to ON upon delivery.

If the DIP switch is set to OFF, the message F.964 appears on the display when the door control unit is switched on for the first time.

**Preparation**

To help you configure the basic settings quickly during initial commissioning, it is recommended that you have the following information to hand:

- Type of limit switch system connected

The basic settings are queried automatically.

**Prerequisites:**



- The door control unit is switched on and error F.964 does not appear on the display.

**Setting limit switches with profile positioning system**

The following appears on the display:

Indicator display	
7-segment	Plain text display
P . 2 0 5	P:Positioning 205= -
-	P:Positioning 205= <u>  </u> ✓

1. Briefly press the  button.

2. Select the value for the connected limit switch using the  or  button:

Limit switch system	Value
Mechanical limit switches 1	
> Absolute limit switches are evaluated as normally closed contacts, pre-limit switches are evaluated as normally open contacts	0000
Mechanical limit switches 2	
> All limit switches are evaluated as normally closed contacts.	0001
Absolute encoder DES-A (GfA)	0300
Absolute encoder DES-B (Kostal)	0700
Position detector TST PD/TST PE	0800
Timer limit switch operation	0900

3. Press and hold the  button for 3 seconds.
  - ↳ Limit switch is set.
  - Basic settings are saved in the door control unit.

**Subsequent settings:**

- If a brake is connected, the brake must be activated via the parameter setting mode. (see "Adjusting the brake", page 61)
- If the door moves in the wrong direction, the motor rotating field is incorrect. This depends on which side of the door the drive is mounted on. To change the rotating field, parameter P.130 must be set from 0 to 1 or vice versa.
- Set door limit positions.  
Depending on the respective limit switch system (electronic or mechanical), they are set either via parameters (process starts automatically) or mechanically. (see "Setting the door limit positions", page 61)

## 11.2 Adjusting the brake

### NOTE

If a brake is connected, it must be set to a relay output (output 1 or output 2).

For further smooth adjustment of the door control unit, the brake must be activated immediately after the basic settings.

### Prerequisites:

The access level is set to password 2. (see "Changing the access level ", page 58).

1. Use the   buttons to select the parameter:

Output 1: P.701

Output 2: P.702

2. Briefly press the  button.

3. Use the  button to enter value 3201.

4. Press and hold the  button for 3 seconds.

↶ The value is saved.

➤ Brake is set to output 2.

Indicator display	
7-segment	Plain text display
P . 7 0 2	P:Output2 702=

## 11.3 Setting the door limit positions



*The settings are implemented in deadman operation.*



### ATTENTION

- If the door does not move, the brake is triggered. Set the brake on a relay output! (see "Adjusting the brake", page 61)
- If the door moves in the wrong direction, the control value in parameter P.130 must be changed from 0 to 1 or vice versa.

### 11.3.1 Electronic limit switch system

Once the basic settings have been saved and a position sensor is connected, the process for setting the door limit positions starts automatically.



The display shows:

- Briefly press the  button.  
↳ Door direction closing travel.
- Press and hold the  button until the required position for the lower limit position is reached.
- Press and hold the  button for 3 seconds.

↳ CLOSE limit position is set.



The display shows:



↳ Door direction opening travel.

- Press and hold the  button until the required position for the upper limit position is reached.
- Press and hold the  button for 3 seconds.  
↳ The OPEN end position is set.
- Briefly press the  button.  
↳ Door closes. The teach-in process starts automatically.

NOTE: The door opens and closes automatically until the teach-in process ends. During the process, the message I.515 is shown on the display.

The pre-limit switch and limit switch are set automatically.

Indicator display	
7-segment	Plain text display
[ 0 ]	! Set Limits ! 0 start with 
E* 1* E* 0*	To Closed Pos. →  0 accept with 

E* 1* E* 0*	To Open Pos. →  xxx accept with 
-------------	---

### 11.3.2 Mechanical limit switch system

#### WARNING

Risk of injury and damage to the door possible

The door can move independently while the limit switch system is being adjusted.

During manual adjustment, press the emergency stop switch on the respective limit switch to prevent uncontrolled door movements.





If there is no emergency stop switch, switch off the door control unit during each adjustment.

#### ATTENTION

Damage to the door and risk of injury!





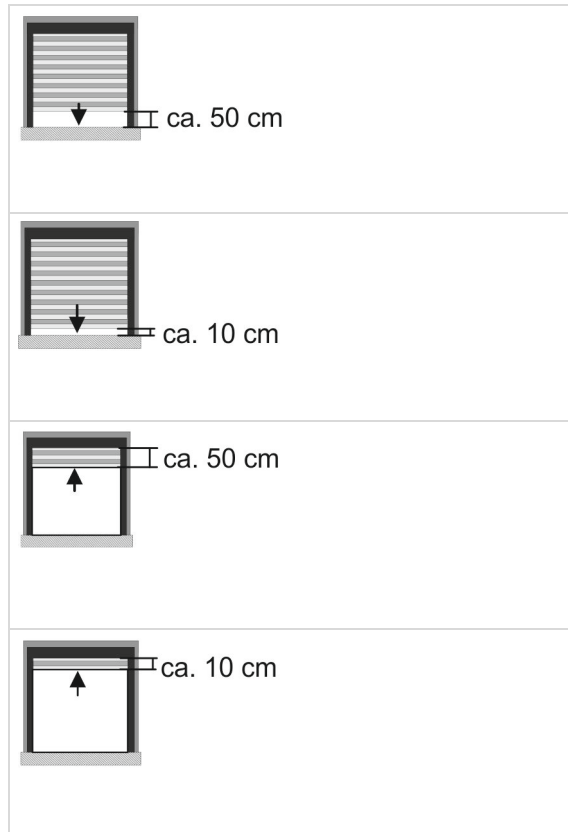

The limit position of the door must not be overrun. Set the limit switch so that there is sufficient distance to the end position. The appropriate distance depends on the type of door and the running speed of the door. A greater distance is recommended for high-speed doors.

**Setting the pre-limit switch and limit switch position for opening and closing movement**

1. Press and hold the  and stop the door at approx. 50 cm before it closes completely.
2. Set the pre-limit switch at the bottom.  
Please note: The door control unit should not be in operation during the adjustment.
3. Press and hold the  button and stop the door at approx. 10 cm before it closes completely.
4. Set the limit switch at the bottom.  
Please note: The door control unit should not be in operation during the adjustment.
5. Press and hold the  button and stop the door at approx. 50 cm before it opens completely.
6. Set the pre-limit switch at the top.  
Please note: The door control unit should not be in operation during the adjustment.
7. Press and hold the  button and stop the door at approx. 10 cm before it opens completely.
8. Set the limit switch at the top.  
Please note: The door control unit should not be in operation during the adjustment.
9. Set the EMERGENCY limit switch at the top.  
Please note: The door control unit should not be in operation during the adjustments.
10. Set the limit switch at the bottom.
11. Check top and bottom limit switch positions in deadman operation.



**Setting the automatic opening and closing of the door**

12. Press and hold the  and  buttons simultaneously for 3 seconds.
    - ↳ The parameter setting mode has been initiated.
    - ↳ The display shows:
  13. Use the   buttons to select parameter P.980.
  14. Briefly press the  button.
  15. Enter value 0.
  16. Press and hold the  button for 3 seconds.
    - ↳ The value is saved.
  17. Press and hold the  button for 3 seconds.
    - ↳ Exit parameter setting mode.
- Door limit positions are set.

Indicator display	
7-segment	Plain text display
P .000	P:Door cycles 000# X CYcl
P .980	P:Operating mode 980=

Door can be opened and closed automatically.

If the door end position is not suitable, the position of the respective limit switches can be subsequently adjusted.

## 12 Function-enhancing configurations

The advanced settings allow customised settings to be made to the door as well as corrections or changes to the preset parameters.



You can find additional parameter settings for the door control system in the "Parameter description" document for the respective door control system.

### 12.1 Correcting the door limit positions

If the set door limit positions do not fit, they can be corrected.

There are two ways of correcting the door limit positions:

- Teaching in the limit positions for opening and closing again.
- Fine adjustment of the limit positions for opening and closing (correction of the respective limit position in increments)







#### NOTE

Correction of the door limit positions using the parameters is only possible if an electronic limit switch has been connected.

#### 12.1.1 Teaching in the door limit positions again

##### Prerequisites:

The parameter setting mode has been initialised; a parameter is shown in the display.

1. Use the   buttons to select parameter 210.
2. Briefly press the  button.
3. Use the  or  button to enter value 5.
4. Press and hold the  button for 3 seconds.
  - ↳ The value is saved.
5. Exit parameter setting mode.

Indicator display	
7-segment	Plain text display
P . 2 1 0	P:New Limits W 210= 0 #

The door control changes automatically into the CALIBRATION mode and the door limit positions must be taught in again. (see "Setting the door limit positions", page 61)

### 12.1.2 Fine adjustment of the door limit positions

The door limit positions can be set for both the opening and closing movement of the door.



#### Prerequisites:

The parameter setting mode has been initialised; a parameter is shown in the display.

1. Press the  and  buttons at the same time.

↪ Parameter setting is active.

↪ The display shows:

2. Use the   buttons to select the parameter:

Open Pos: P.231

Closed Pos: P.221

Indicator display	
7-segment	Plain text display
P . 0 0 0	P:Door cycles 000# X CYcl
P . 2 3 1	P: Adj Opn Pos. W 231= 0 Inc
or P . 2 2 1	P: Adj Cls Pos. W 221= 0 Inc

3. Briefly press the  button.

4. Use the   buttons to select the value.



*The value is entered in increments. A negative value (-x) shifts the limit position downwards. A positive value shifts the limit position upwards.*

*It is recommended to adjust the value in small increments.*

5. Press and hold the  button for 3 seconds.

↪ The value is saved.

6. Exit parameter setting mode.

7. Open or close the door accordingly using the   buttons.

↪ The door moves to the set limit position.

*Adjust the value again if necessary.*

- Fine adjustment of the respective limit position is complete.

## 12.2 Adjusting the end holding point of the door

Pre-limit switches and limit switches have an influence on the end holding point of the door.

With an electronic limit switch system (position sensor), the correct position of the pre-limit switch and the limit switch band is determined by the automatic limit switch correction. If the set positions do not match the door situation, they can be adjusted manually.

### ATTENTION

Damage to the door or surroundings if the pre-limit switch and limit switch band are incorrectly configured!

If the automatic configuration of the pre-limit switch and the limit switch is deactivated and the values for the limit switches are set too low, the door moves beyond the limit positions. This can result in damage to the door or the surrounding area.

Individual settings for pre-limit switches and limit switches are only permitted to be implemented by trained personnel.



The position of the pre-limit switch and limit switch is automatically determined when setting the door limit positions in SET LIMITS mode.

**Prerequisites:**

- A position sensor is connected.
- The access level is set to password 2. (see "Changing the access level ", page 58).
- Parameter setting is initialised; a parameter is shown in the display.

The settings can be implemented for both the opening and closing movement of the door.

To be able to customise the position of the pre-limit switch and limit switch band, the automatic configuration must be deactivated.

**Deactivating the automatic configuration**

1. Use the buttons to select parameter 216.

2. Briefly press the button.

3. Use the or button to enter value 1.

4. Press and hold the button for 3 seconds.

↳ Automatic configuration of the pre-limit switch and limit switch is deactivated.

Indicator display	
7-segment	Plain text display
P . 2 1 6	P:Positioning W 216= 2

**Manually adjusting the pre-limit switch position**

5. Briefly press the button.

6. Use the buttons to select the parameter:  
Opening: P.232  
Closing: P.222

P . 2 3 2	P:Upper Limit W 232= x Inc
or	
P . 2 2 2	P:Lower Limit 222= x Inc

7. Briefly press the button.

8. Use the buttons to select the value.

The position of the pre-limit switch is entered in increments in a range of 0–2100. The selected value depends on the respective door situation and must be determined.

NOTE: If a higher value is entered, make sure that the value is not too high; otherwise, the door will slow down too early. If the value is too low, the door may travel beyond the door limit positions.

9. Press and hold the button for 3 seconds.

↳ The value is saved.



10. Exit parameter setting mode.

11. Open or close the door accordingly using the buttons.

If necessary, the length of the crawl speed must be adjusted again by changing the value.

**Adjust limit switch band manually**

12. Initiate parameter setting mode.

13. Use the   buttons to select the parameter:  
Opening: P.233  
Closing: P.223

P .233	P:Open Pos h 233= x Inc
or	
P .223	P:Closed Pos h 223= x Inc

14. Briefly press the  button.

15. Use the  or  button to enter the value.



*The limit switch band is entered in increments in a range of 0–250. The selected value depends on the respective door situation and must be determined.*

*NOTE: If a higher value is entered, make sure that the value is not too high; otherwise, the door will slow down too early. This can result in the overtravel being too short and the door not closing or opening completely. If the value is too low, the door may travel beyond the door limit positions.*

16. Press and hold the  button for 3 seconds.

☞ The value is saved.

17. Exit parameter setting mode.

18. Open or close the door accordingly using the   buttons.

*If necessary, the final stopping point of the door must be adjusted again by changing the value.*

➤ The position of the pre-limit switch and limit switch is set.

## 13 Messages on the display

Messages are shown on the display. They provide information about the current status, notes and errors.

There are 3 types of messages:

- Information messages (abbreviation I.)
- Incoming messages (abbreviation E.)
- Error messages (abbreviation F.)
- General messages (various abbreviations)

General messages		
7-segment display	Plain text display	Description
FEIG EWA4	FEIG EWA4 Self Check	<b>Power Up and Self Check</b> → initial message after switch-on
CLO@	Door closing	<b>Closing active</b>
@OPE	Door opening	<b>Opening active</b>
'Au'	Automatic	<b>Automatic</b> → indicates change from "Manual" to "Automatic" status"
CALI	Calibration start with <b>Æ</b>	<b>Calibration</b> → Set the limit positions in deadman mode (with position sensor) → Start the process with the STOP button.
_Eu_	FEIG ELECTRONIC XXX door cycles	<b>CLOSE limit position</b>
≡Eu≡	Locked in close position	<b>CLOSE limit position locked</b> → No opening travel possible (e.g. airlock)
˘Eo˘	FEIG ELECTRONIC XXX door cycles	<b>OPEN limit position</b>
≡Eo≡	Locked in open position	<b>OPEN limit position locked</b> → No closing travel possible (e.g. safety edge, photoeye)
-E1-	Partial Open Pos	<b>Middle limit position E1 (intermediate stop position)</b>
≡E1≡	Locked in middle position	<b>Middle limit position locked</b> → No closing travel possible
'Hc'	Auto/Jog	<b>Auto/Jog</b> → indicates change from status "Manual" to "Auto/Jog"
'Hd'	Deadman operation	<b>Manual</b> → deadman operation
≡NA≡	Emergency stop	<b>Emergency stop</b> → Movement not possible, hardware safety chain interrupted
EMER	Emergency jog	<b>Emergency jog</b> → Deadman travel without regard for safeties, etc.etc.
FAIL	Error/fault	<b>Fault</b> → Only deadman travel is possible, automatic opening may also be possible
E.050	Stop-Keypad	<b>Stop/reset mode</b> → wait for next incoming command

<b>SYNC</b>	! Synchron. !	<b>Synchronisation</b> (incremental encoder, position sensor/limit switch → Pos. unknown)
-------------	---------------	---

<b>Status messages during calibration</b>		
<b>7-segment display</b>	<b>Plain text display</b>	<b>Description</b>
<b>E.i.E.c.</b>	To Closed Pos. → ⇅ Accept with Æ	Calibration of CLOSE limit position requested (in deadman operation)
<b>E.i.E.o.</b>	To Open Pos. → ↑ Accept with Æ	Calibration of OPEN limit position requested (in deadman operation)
<b>E.i.E.1.</b>	To Part. Pos. → ⇅	Calibration of the intermediate stop position E1 (in deadman operation)

<b>Status messages during synchronization</b>		
<b>7-segment display</b>	<b>Plain text display</b>	<b>Description</b>
<b>S.y.E.c.</b>	Closed position OK	Synchronization of CLOSE limit position requested (Deadman travel or wait for start command)
<b>S.y.E.o.</b>	Open position OK	Synchronization of OPEN limit position requested (Deadman travel or wait for start command)
<b>S.y.E.1.</b>	To Part. Pos. → ⇅	Synchronization of intermediate stop position E1 (in deadman travel)
<b>S.y.op</b>	↑ To Begin	Automatic opening up to mechanical stop, then automatic synchronization of OPEN limit position
<b>S.y.cL</b>	↓ To Begin	Automatic closing taking into account safeties up to mechanical stop, followed by automatic synchronization of CLOSE limit position
<b>S.y.c≡</b>	Auto syn. to lock	Automatic closing is locked due to request Å

<b>Status messages during deadman movement</b>		
<b>7-segment display</b>	<b>Plain text display</b>	<b>Description</b>
<b>Hd.cL</b>	Jog Close	Jog Close (CLOSE button)
<b>Hd.oP</b>	Jog Open	Jog Open (OPEN button)
<b>Hd.Eu</b>	Deadman close	CLOSE limit position reached, no further Jog Close possible
<b>Hd.Eo</b>	Deadman open	OPEN limit position reached, no further Jog Open possible

<b>Hd.Ao</b>	Outside open	Outside of permitted OPEN limit position (no Jog Open possible)
<b>Messages during parameter setting</b>		
<b>7-segment display</b>	<b>Plain text display</b>	<b>Description</b>
<b>noEr</b>	Err History	Error history
<b>Er--</b>	Empty	Error history is empty
<b>Prog</b>	Factory Default	Programming message while implementing original parameters or default set
<b>Messages for inputs</b>		
<b>7-segment display</b>	<b>Plain text display</b>	<b>Description</b>
<b>E.000</b>	Open-Keypad	OPEN foil button
<b>E.050</b>	Stop-Keypad	Stop foil button
<b>E.090</b>	Close-Keypad	CLOSE foil button
<b>E.101</b>	LCD text of input + terminal no.	Input 1
<b>E.102</b>	LCD text of input + terminal no.	Input 2
<b>E.103</b>	LCD text of input + terminal no.	Input 3
<b>E.104</b>	LCD text of input + terminal no.	Input 4
<b>E.105</b>	LCD text of input + terminal no.	Input 5
<b>E.106</b>	LCD text of input + terminal no.	Input 6
<b>E.107</b>	LCD text of input + terminal no.	Input 7
<b>E.108</b>	LCD text of input + terminal no.	Input 8
<b>E.109</b>	LCD text of input + terminal no.	Input 9
<b>E.110</b>	LCD text of input + terminal no.	Input 10
<b>E.111</b>	LCD text of input + terminal no.	Input 11
<b>E.112</b>	LCD text of input + terminal no.	Input 12
<b>E.113</b>	LCD text of input + terminal no.	Input 13
<b>E.114</b>	LCD text of input + terminal no.	Input 14
<b>E.115</b>	LCD text of input + terminal no.	Input 15
<b>E.121</b>	LCD text of input + terminal no.	Input 21
<b>E.122</b>	LCD text of input + terminal no.	Input 22
<b>E.123</b>	LCD text of input + terminal no.	Input 23
<b>E.124</b>	LCD text of input + terminal no.	Input 24
<b>E.125</b>	LCD text of input + terminal no.	Input 25

<b>E.126</b>	LCD text of input + terminal no.	Input 26
<b>E.127</b>	LCD text of input + terminal no.	Input 27
<b>E.128</b>	LCD text of input + terminal no.	Input 28
<b>E.13A</b>	LCD text of input + terminal no.	Input 3A
<b>E.13B</b>	LCD text of input + terminal no.	Input 3B
<b>E.13C</b>	LCD text of input + terminal no.	Input 3C
<b>E.13D</b>	LCD text of input + terminal no.	Input 3D
<b>E.13E</b>	LCD text of input + terminal no.	Input 3E
<b>E.13F</b>	LCD text of input + terminal no.	Input 3F

#### Safety/emergency stop chain

7-segment display	Plain text display	Description
<b>E.211</b>	E-stop Ext 1	External E-stop 1 triggered
<b>E.212</b>	E-Stop Ext 2	External E-stop 2 tripped

#### Safety edge in general

7-segment display	Plain text display	Description
<b>E.360</b>	Closing edge	Triggering of the first <b>internal</b> safety edge
<b>E.370</b>	Closing edge	Triggering of the first <b>external</b> safety edge
<b>E.380</b>	Edge Tripped	Triggering of the second <b>internal</b> safety edge
<b>E.3F0</b>	Edge Tripped	Triggering of the second <b>external</b> safety edge

#### Wireless plug-in module

7-segment display	Plain text display	Description
<b>E.401</b>	Radio Ch1	Radio channel 1
<b>E.402</b>	Radio Ch2	Radio channel 2

<b>Induction loop detector</b>		
<b>7-segment display</b>	<b>Plain text display</b>	<b>Description</b>
<b>E.501</b>	Loop Ch1	Detector channel 1
<b>E.502</b>	Loop Ch2	Detector channel 2
<b>E.503</b>	Loop Ch3	Detector channel 3
<b>E.504</b>	Loop Ch4	Detector channel 4
<b>WiCab inputs</b>		
<b>7-segment display</b>	<b>Plain text display</b>	<b>Description</b>
<b>E.F01</b>	Air Safety In.1	Input 1 of mobile unit
<b>E.F02</b>	Air Safety In.2	Input 2 of mobile unit
<b>E.F03</b>	Air Safety In.3	Input 3 of mobile unit
<b>E.F04</b>	Air Safety In.4	Input 4 of mobile unit
<b>E.F0A</b>	StatSafety In.A	Input A of stationary unit
<b>E.F0B</b>	StatSafety In.B	Input B of stationary unit
<b>E.F0C</b>	StatSafety In.C	Input C of stationary unit

## 14 Troubleshooting

Troubleshooting helps to solve typical faults in the door sequence and causes of display messages.

Type of fault	Check	Yes/ no	Possible cause	Remedy
<b>Door</b>				
Door does not move.	Brake connected?	yes	Brake releases	Adjust the brake
Door moves in the wrong direction.			Motor rotating field runs incorrectly	Change parameter P.130
Door does not move or stops shortly afterwards.			Motor power too low.	<ul style="list-style-type: none"> <li>Check spring tension</li> </ul>
Door reversed.			Cable break in the spiral cable of the safety edge	Check the spiral cable of the safety edge for defects
			Obstacle in the movement area or light beam	Remove obstacle
			Photoeye soiled	Clean the photoeye
Door does not open or close completely.	Does the door stop before the set limit position?	yes	Limit switch set incorrectly	Readjust limit switch
<b>Indications on display</b>				
F.090			DIP switch is set to OFF and basic settings not yet completed	Set DIP switch to ON
F.369	Safety edge connected?	yes	Incorrect parameter value, safety edge not activated	Correct parameter value for safety edge
		no		<ul style="list-style-type: none"> <li>Connect the safety edge</li> <li>If no safety edge is required, set parameter P.460 to value 0</li> </ul>
F.363	Safety edge connected?	Yes	Safety edge active, but incorrectly connected	<ul style="list-style-type: none"> <li>Check connections</li> </ul>
		no		<ul style="list-style-type: none"> <li>Connect the safety edge</li> <li>If no safety edge is required, set parameter P.460 to value 0</li> </ul>
E.105	Photoeye connected?	yes	Photoeye incorrectly connected	Correct the photoeye connections
			Photoeye interrupted	Remove obstacle from light beam or clean photoeye
		no	Input 5 not used	Connect 24 V bridge to input 5

E.102	External switch connected?	no	Input 2 not used	Connect 24 V bridge to input 2
-------	----------------------------	----	------------------	--------------------------------

## 15 Maintenance and disposal

### 15.1 Maintenance

#### WARNING

Damage to the control unit!

There are exposed live parts on the control board. These must not come into contact with water or other cleaning agents.

> Only clean the outside of the housing.

Use cleaning cloths when cleaning to prevent scratches to the display surface.

Do not use any chemical or corrosive cleaning agents.

### 15.2 Disposal of the product



At the end of its service life, dispose of the product in accordance with the valid legal specifications.

Batteries contain toxic materials. It is illegal to dispose of batteries along with domestic waste.

Batteries must be collected separately and recycled in an environmentally friendly procedure.



Where applicable, dispose of batteries in an environmentally friendly manner. Hand over empty batteries to a qualified specialist workshop or a collection point for old batteries.

## 16 Technical data

Housing	
<b>Dimensions of housing (B x H x T)</b>	182 x 331 x 93 mm
<b>Degree of protection</b>	IP 54
<b>Weight</b>	~ 2 kg
<b>Height above sea level</b>	max. 2000 m

Control system		
<b>Temperature</b>	<b>Operation</b>	-20 to +50 °C
	<b>Storage</b>	-20 to +70 °C
<b>Air humidity</b>		up to 95% non condensing
<b>Noise emission</b>		<20 dB (A)
<b>Height above sea level</b>		max. 2000 m
<b>Protection class</b>		1

<b>Supply voltage via Terminal L, N, PE</b>	1~110–240 V, 50–60 Hz 3~200–415 V, 50–60 Hz Note: Terminal N absolutely necessary
<b>Control voltage/ External supply 2</b>	24 VDC regulated ( $\pm 10\%$ at nominal voltage 230 V) Controller variant: max. 500 mA incl. optional plug-in modules, Short-circuit protected by central switching regulator, short-circuit protected by central switching regulator.

<b>Control inputs</b>	24 VDC / typ.15 mA, max. 26 VDC / 20 mA all inputs must be connected potential-free or < 5 V: inactive à logical 0 > 7 V: active à logical 1 min. signal duration for input control commands: > 100 ms
-----------------------	--

Control outputs	
<b>Transistor outputs OUT15</b>	24 VDC / min. 10 mA / max. 120 mA
<b>Relay K1 and K2</b>	Changeover contact free of potential min. 10 mA / max. 230 VAC / 3A
<b>Drive output</b>	up to 0.75 kW at 115 up to 1.5 kW at 230 up to 2,2 kW at 400 Continuous motor current at 100% duty cycle and ambient temperature: 5A

## 16.1 Dimensions

### 16.1.1 Housing dimensions

