



Elektromagneet inox 8000N Monitored



TECHNISCHE KENMERKEN

- Afmetingen Magneet : 222 x 62 x 42 mm
- Afmetingen Ankerplaat : 185 x 61 x 16,5 mm
- Houdkracht : 3000N
- Stroomverbruik : 480 mA ± 10% @ 12VDC
240 mA ± 10% @ 24VDC
- Contacten : 1 x NO/NC/COM contact
- Werkingstemperatuur : -10 tot 55°C
- Gewicht : 5,5KG

AFMETINGEN

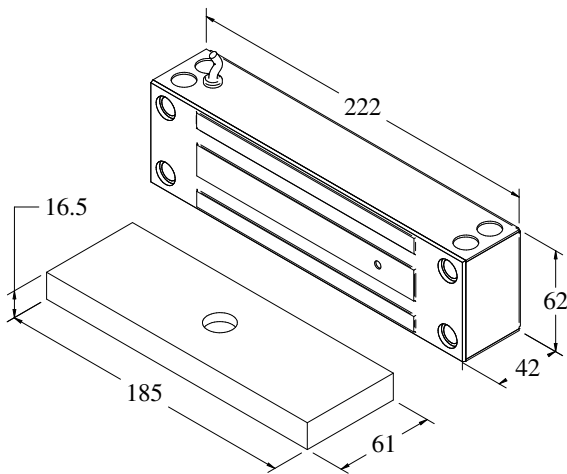

AANSLUITSCHEMA

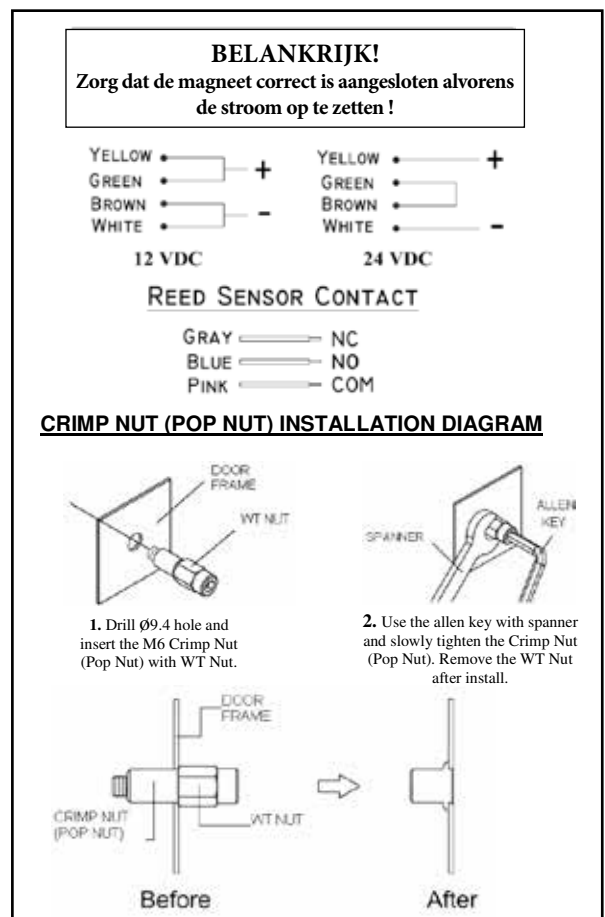

BESTELINFORMATIE

- EM205710 : Elektromagneet INOX 8000N Monitored
- EM205750 : L Haak
- EM205751 : LZ Haak