



Waterbestendige Elektromagneet 1500N Monitored



TECHNISCHE KENMERKEN

- Afmetingen Magneet : 165 x 34,5 x 27,5 mm
- Afmetingen Ankerplaat : 130 x 33 x 11 mm
- Houdkracht : 1500N
- Contacten : 1x NO/N.C./COM
- Stroomverbruik : 300 mA ± 10% @ 12VDC
150 mA ± 10% @ 24VDC
- Temperatuur : -10 to 55°C
- Gewicht : 1,5 KG

AFMETINGEN

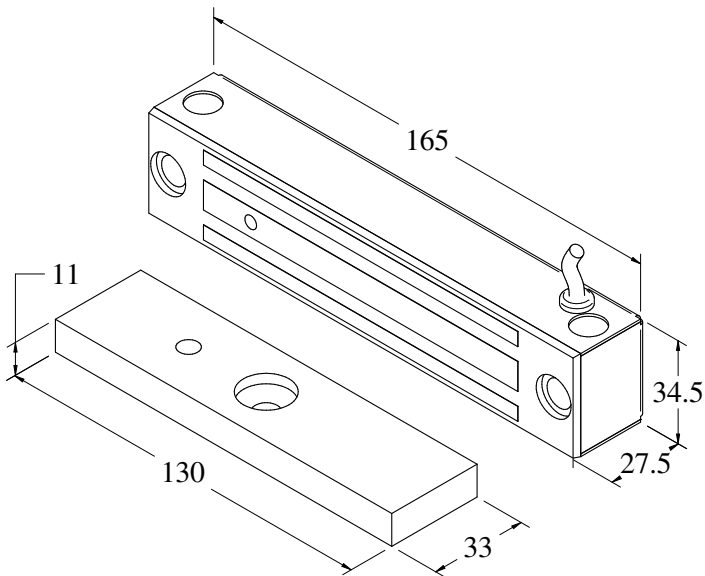

AANSLUITSCHEMA

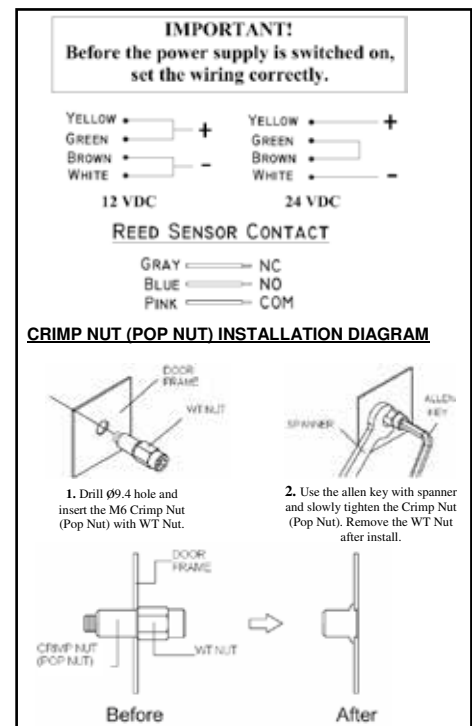

BESTELINFORMATIE

- EM205411: Waterbestendige Elektromagneet 1500N Monitored