

INSTRUCTION MANUAL

DAAB AUTOMATIC CONTROL UNIT EP105



FAAC Nordic AB
BOX 125, SE-284 22 PERSTORP SWEDEN, ☎ +46 435 77 95 00, ✉ support@faac.se
www.faac.se

Revision 1

Contents

EC Declaration of Conformity (original version)	4
Declaration of performance	4
Safety	5
Safety classification	5
Operation	6
General	6
Service and maintenance	6
Resetting/replacing tripped fuses	6
Connection	7
Safety	7
Installation	7
High current	7
Motors	7
Description of the EP105	9
General	9
Intended use	9
Identification	9
Reference documentation	9
Disposal of electronic equipment	9
Instruction manual	9
Installing the EP105 PCB	11
Authorisation	11
Enclosure	11
Installing the PCB	11
Connecting a safety edge	12
Connecting safety edges and photocells	12
Connecting an encoder (electronic limit switch)	13
Connecting a mechanical limit switch (microswitch)	13
Connecting timer control limit switches	13
Configuring the EP105	14
General	14
Readout of parameters in the EP105	14
Setting parameters in the EP105	14
Locked settings	15
Configuration channels C700 - C712	15
Message channel C904	15
Display channel C999	15
Signal list	16
Low current	16
Indications	17
Applications	18
Folding doors	18
Sliding doors/sliding gates	18
Up-and-over doors	18
Swing gates	18
Barriers	18
Quick guide to commissioning of swing gate	19
Conditions	19
Commissioning of drive unit 1	19
Commissioning of drive unit 2	20

Commissioning	21
Safety.....	21
Stop circuit	21
Frequency converter	21
Limit switches.....	22
Direction of rotation of motors	23
Setting of motor protection	23
Type of power supply	23
External protection units.....	24
Load guard.....	25
Safety edges	26
Input for photocell.....	28
Limited running time	28
Checking LED indications	28
Pulse mode and hold-to-run mode.....	29
Checking safety functions.....	29
Setting electric motor braking.....	29
Programmable inputs, P channels	30
Automatic closing	30
Run-on time with mechanical limit switches.....	31
Run-on with encoder.....	32
Reverse	32
Functions using add-in cards	32
Channel list	33
General, C-channels	33
Limit switch, L-channels.....	44
Programmable inputs, P channels	46
Error messages in display and in the error code list in channel C903	53
Messages in display and in the error code list in channel C903	56
Troubleshooting	56
Resetting/replacing tripped fuses.....	57
Notes:	58
Notes:	59

EC Declaration of Conformity (original version)

Manufacturer

FAAC Nordic AB
Box 125, 284 22 Perstorp, Sweden

Person authorised to compile the technical documentation

Ulf Ivarsson, FAAC Nordic AB, Box 125, 284 22 Perstorp, Sweden

General description and type designation

Automatic control unit for doors, gates or barriers: EP105-1, EP105-2

We hereby declare that the EP105 automatic control unit meets the relevant requirements of Machinery Directive 2006/42/EC, EMC Directive 2014/30/EU, Low Voltage Directive 2014/35/EU, RoHS Directive 2011/65/EU including (EU)2015/863 and Construction Products Regulation EU 305/2011.

The automatic control unit EP105-1, EP105-2 is, where applicable, compliant with the following harmonised standards:

- SS-EN 13241+A2:2016 Industrial, commercial, garage doors and gates. Product standard, performance characteristics
- SS-EN 13849-1:2016 Safety of machinery. Safety-related parts of control systems – Part 1: General principles for design.
- SS-EN 60335-1 Household and similar electrical appliances - Safety - Part 1: General requirements.
- SS-EN 60335-2-103 Household and similar electrical appliances - Safety - Part 2-103: Particular requirements for drives for barriers, doors and windows.
- SS-EN 61000-6-2 Electromagnetic compatibility (EMC) - Part 6-2: Generic standards - Immunity for industrial environments.
- SS-EN 61000-6-3 Electromagnetic compatibility (EMC) - Part 6-3: Generic standards - Emission standard for residential, commercial and light-industrial environments.

This declaration relates to automatic control unit EP105-1, EP105-2 specified in the condition in which it is placed on the market, and does not cover components added and/or modifications made thereafter. Nor does it relate to third-party supplied equipment or to interfaces between third-party equipment and the equipment specified below and supplied by FAAC Nordic AB. The instruction manual/installation manual for automatic control unit EP105-1, EP105-2 must be followed and attention must be paid to risks in the installation of a door, gate or barrier.

We declare that the EP105 does not contain, in concentrations above 0.1%, any substances specified in the REACH (1907/2006/EC) Candidate List of Substances of Very High Concern or banned substances in RoHS, 2011/65/EC.

Declaration of performance

Intended use of the construction product

Automatic control unit intended for installation in doors, gates or barriers for use in industry, commercial areas and residential areas that are open to the public, and intended to provide secure access for people, goods and vehicles.

System for the assessment and continuous verification of the performance of the construction product

System 3

Performance

Property	Performance	Harmonised standard
Force exerted		SS-EN 13241 + A2:2016
• Safety edge	Performance level c	SS-EN 13849-1:2016
• Load guard	Performance level d	SS-EN 13849-1:2016

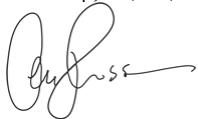

Perstorp, 06/12/2021



Ola Hansson, CEO

Safety

CAUTION: Important safety instructions Following these instructions is important for personal safety Retain these instructions

 Carefully read through this instruction manual in its entirety – it contains important information about safety, installation, commissioning and use. Particularly important safety information is identified with the symbol  in the left margin.

If you fail to follow the safety instructions in this instruction manual, there is a risk of serious damage to property or injury to animals or people. You should keep this instruction manual in a safe place for future use.

EP105 or unit controlled by EP105 can be used by children from the age of 8 years and by people with physical, sensory or mental disabilities or inadequate experience and knowledge if it takes place under supervision, or if they have been given instructions on how to use an EP105 or a unit controlled by an EP105 and understand the dangers that may arise.

Children must not play with the installation or the controlled units. Cleaning and maintenance must not be performed by children.

The EP105 control unit or the accessories recommended by FAAC Nordic AB must not be modified without the express consent of FAAC Nordic AB.

Only qualified persons working in their own fields may perform installation, adjustment, commissioning, repair and other work.

Electrical connections may only be made by qualified electricians, who accept responsibility for the connections.

Follow the safety instructions of the equipment to be controlled by the control unit.

- **Safety classification**

FAAC Nordic AB has validated the safety circuits in the EP105 to performance level PL = c and Category 2 as defined in SS-EN ISO 13849-2:2008.

The EP105 is designed with safety edge inputs and an integrated load guard for use in personal safety applications. These features are designed to meet the requirements of Machinery Directive 2006/42/EC.

The validation process assumed a technical service life of 10 years or 1 million operating cycles for components in safety circuits.

FAAC Nordic is unable to guarantee this validation when the motor contactors and safety edges exceed this technical service life. For this reason, these components should be replaced before the end of their service life.

Operation

• General

 Anyone installing or modifying the EP105 must have documented familiarity with, and understanding of its functions, as well as experience of setting up the control system for the application in which it will be used.

Take care when operating internal buttons to avoid touching live components.

The unit may only be connected by a qualified electrician, who accepts responsibility for ensuring that the electric connections have been carried out in accordance with the applicable standards and this instruction manual.

Anyone commissioning the EP105 must have documented familiarity with, and understanding of its functions, as well as experience of commissioning control systems for the application to be used.

• Service and maintenance

 Regular inspection is required of the external safety features of the EP105, such as safety edges, stop buttons, photocells, load guards and safety loops. The condition of the enclosure, cables and installation must also be checked. This inspection must be carried out at least twice a year.

CAUTION: EP105 must be disconnected from its power supply during cleaning, maintenance and in replacement of parts or repairs.

• Resetting/replacing tripped fuses

If the fuse protecting the power supply to the automatic control unit trips, FAAC Nordic AB recommends following these steps to reset/replace it.

- Switch off the main switch to the automatic control unit.
- Decouple the drive unit.
- Reset or replace the fuse.
- Switch on the main switch to the automatic control unit.
- Check that none of the drive units start before receiving the control signal.
- Check that the drive units can be started and stopped from the control buttons.
- If the drive unit cannot be stopped, contact FAAC Nordic AB.

Connection

CAUTION: Important safety instructions Follow all instructions,, as incorrect installation can cause serious injury.

- Safety

The electrical connections may only be made by a qualified electrician, who accepts responsibility for ensuring that the electric connections have been carried out in accordance with the applicable standards and this instruction manual.

Always disconnect the power supply when connecting the control box.

Mechanical installation of the control unit must be carried out by persons with the necessary knowledge for the task.

- Installation

The location of the control unit must be selected with regard to the protection class of the enclosure, at least IP54. A heating and/or cooling element should be included if necessary to maintain the operating temperature stated in the technical specification.

The control unit must be securely fixed to a wall or a bracket intended for this purpose, using screw joints. The fixing holes are on the rear or underside of the enclosure. Cables into and out of the enclosure must have cable entry seals that are approved for use with the particular cable. Cables outside the enclosure must be securely fixed to the surrounding structure. They must not hang loose and there must be no possibility of them catching on passing objects.

- High current

The power supply must be connected via a lockable main switch, and have a T10A protection. Connect the incoming earth to the earth bar.

Check that the power supply and motor voltage are compatible.

- Motors

The largest motor that can be connected is 1.5 kW (3-phase 3x400 V).

See "Commissioning" for details of how to check the direction of rotation.

Connecting motors to EP105

Supply 3x400V with neutral

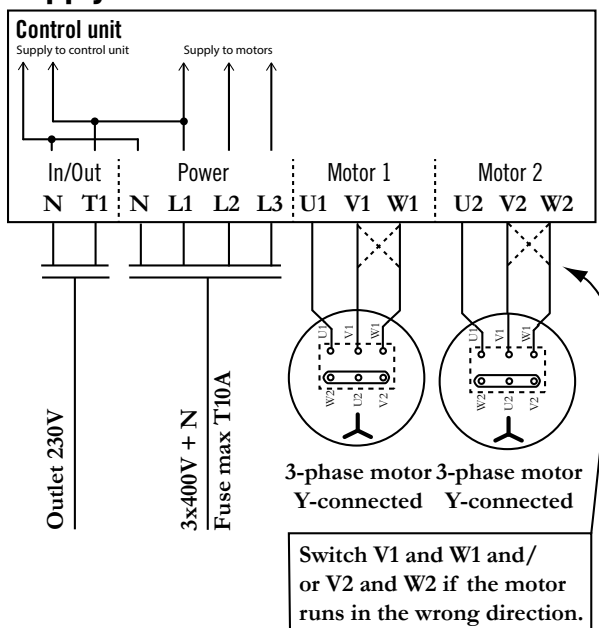

Supply 3x230V without neutral

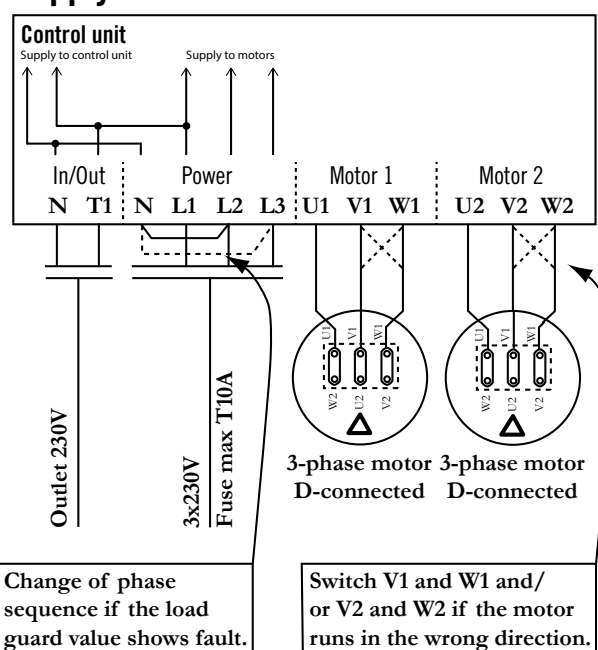

For information about connecting to the frequency inverter, see the instructions for add-in card DB409.

Supply 1x230V with neutral (symmetrical)

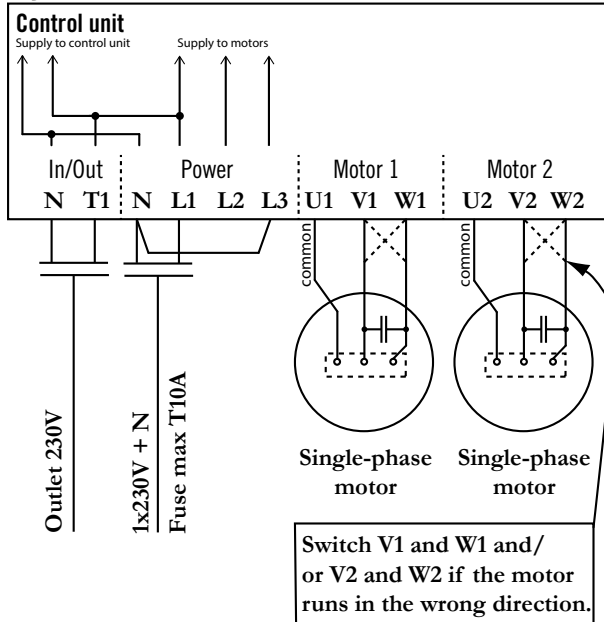

If a symmetrical single-phase motor is used (as shown on the left) make the following changes.

EP105-1: Swap the cable at X12: L1-1 with X12: L1-C1.

EP105-2: Remove the cable between X11: L2-1 and X4: L2-2.

Swap the cable at X12: L1-1 with X12: L1-C1. Swap the cable at X7: L1-2 with X7:L1-C2. See the diagram below for the terminal locations.

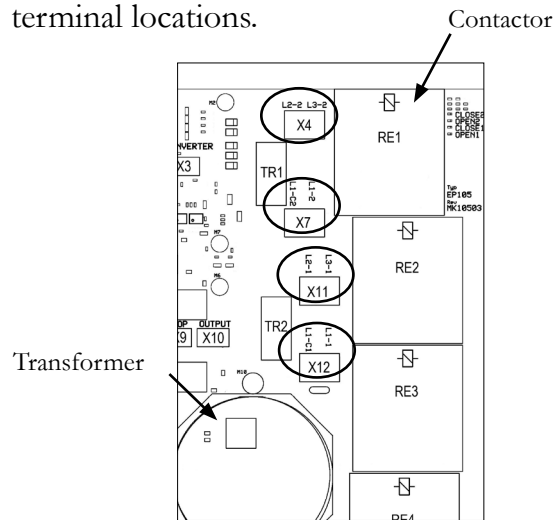

Supply 1x230V with neutral (asymmetrical)

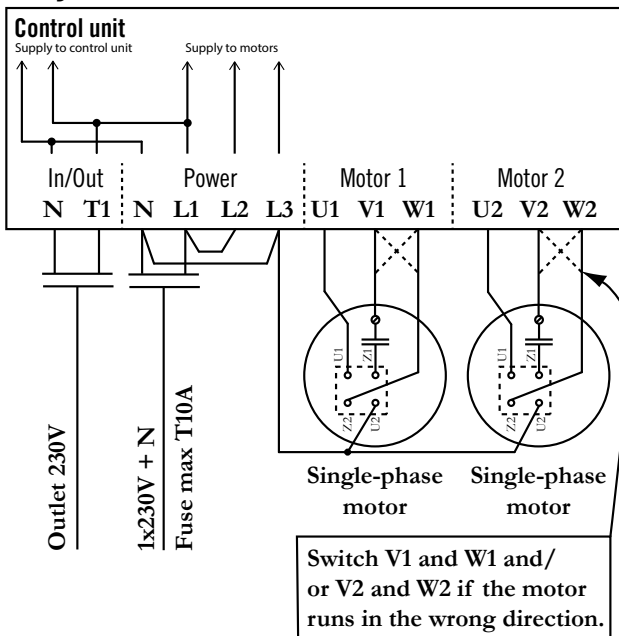

Description of the EP105

- General

The EP105 is an automatic control unit for doors, gates, up-and-over doors and barriers, including all the components necessary to control electric motors – contactors, motor protection, load guards, safety edges, alarm indications, buttons on the PCB for operation and display, and a programming keypad.

The control unit can be supplied with accessories such as a vehicle loop, wireless functionality, signal lights and magnetic locks.

- Intended use

The purpose of the automatic control unit is to open and close doors, gates, up-and-over doors and barriers, using controllers connected to the unit.

No other use is permitted without the written agreement of FAAC Nordic AB.

- Identification

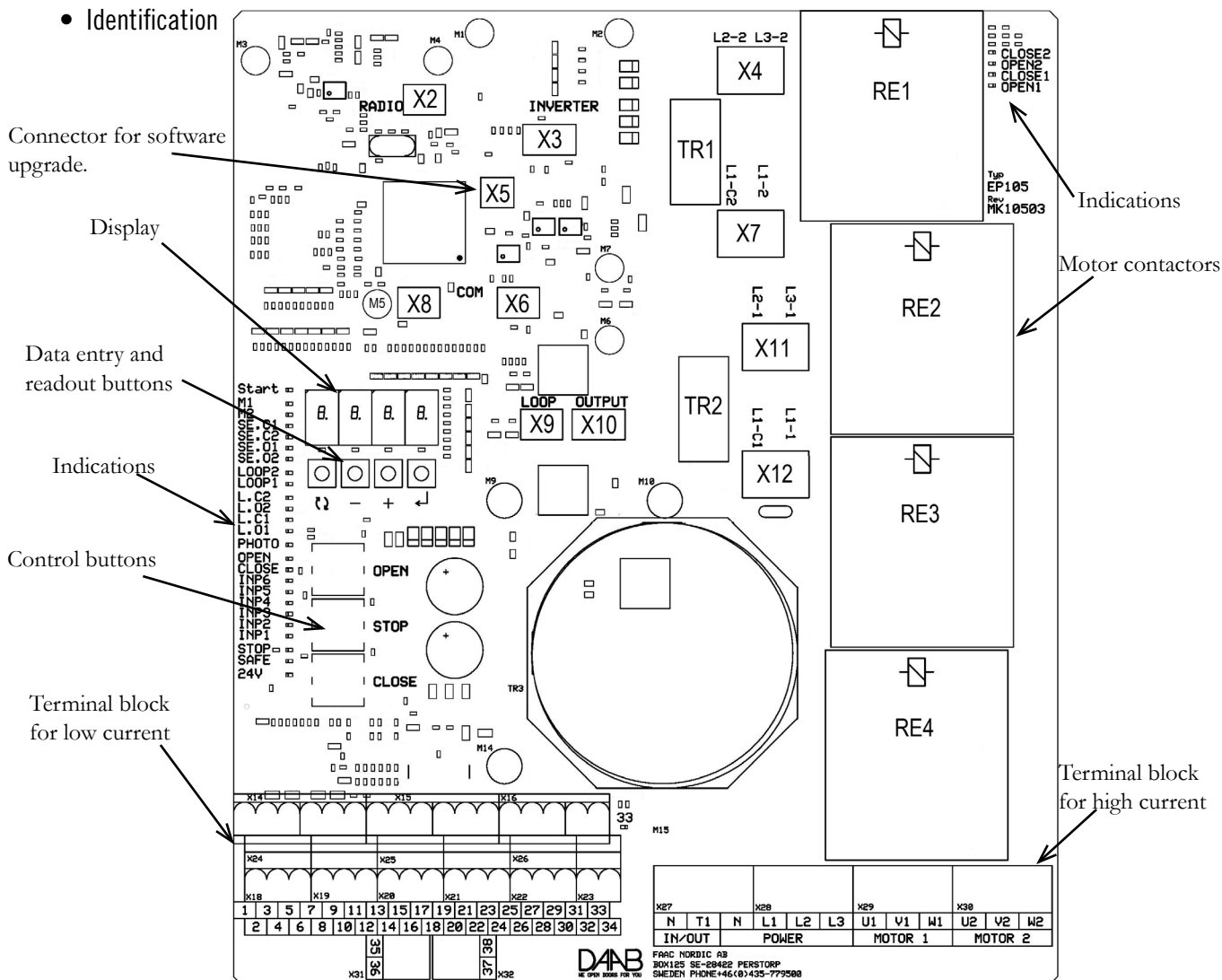

- Reference documentation

- Instruction manual for drive unit
- Instruction manual for the door, gate or barrier

- Disposal of electronic equipment

The EP105 is an electronic product, and as such is classified as hazardous waste. All used electronic equipment must be sent for recycling by a company authorised under environmental legislation to handle hazardous waste including electronic equipment. FAAC Nordic AB will not charge to process used electronic products supplied by us, provided they are returned to us.

- Instruction manual

This instruction manual, or an instruction manual that fully complies with the requirements of the applicable Machinery Directive and Low Voltage Directive and related relevant harmonised standards, must be provided with the finished control unit to the installer and the end user.

Technical specification

Dimensions (WxHxD)	190x224x60 mm.
Power supply	3-phase or single-phase.
Power supply	3x400 V+N+PE, 3x230 V+PE, 1x230 V+N+PE, 3x400 V+PE (requires an external transformer)
Permitted voltage variation	±10%
Frequency	50 Hz.
Motor in 3-phase operation 3x400 V	3-phase asynchronous motor 0.18-1.5 kW.
Motor in 3-phase operation 3x230 V	3-phase asynchronous motor 0.18-0.75 kW.
Motor in single-phase operation	Single-phase motor with capacitor 0.18-0.37 kW.
Fuses	External fuse max. T10A.
Power consumption	Automatic control unit 22 VA + electric motors.
Operating mode	Intermittent operation 50% / maximum period of operation 2 minutes
Temperature range	0 to 45 °C.
Safety edge	2 closing inputs SE.C1 and SE.C2 for a safety edge while closing.
	2 opening inputs SE.O1 and SE.O2 for a safety edge while opening.
	Variable impedance range 1.0-9.9 kΩ, power capability at least 0.5 W.
Safety circuit	Maximum resistance 3 Ω total in the whole safety circuit.
	Cable length at 0.75 mm ² max 60 m. Cable length at 1.5 mm ² max 120 m.
Internal motor protection	Setting range 0.5-6 A.
Load guard	Setting range 0.05-1.99 kW.
Programmable inputs	6x
	Low level 0-8 VDC, high level 12-30 VDC
	Input current 6 mA at 24 VDC.
	Cable length maximum at cable cross-sectional area 0.75 mm ² (Ø 1 mm)
Limit switch/Encoder	2+2 inputs
	Input current 2 mA at encoder and 22 mA at limit switch
	Cable length mechanical limit switches maximum 200 metres at cable cross-sectional area 0.75 mm ² (Ø 1 mm)
	Cable length DB405 maximum 50 metres at cross-sectional area 0.75 mm ² (Ø 1 mm)
Photocell	1 input
	Low level 0-8 VDC, high level 12-30 VDC
	Input current 6 mA at 24 VDC.
	Cable length maximum at cable cross-sectional area 0.75 mm ² (Ø 1 mm)
	Supply voltage VDC max 50 mA.
External supply	Unregulated 24 VDC, 18- 28 VDC, max 300mA
Degree of protection	The PCB is designed for an enclosure rating of at least IP54.

Installing the EP105 PCB

If you are installing the PCB in a dedicated enclosure, you must follow the instructions below. Otherwise, the requirements of the applicable EU directive will not be met, FAAC Nordic's declaration of conformity will not be valid and the product will not be authorised for use. If the PCB is installed elsewhere, the installer is responsible for obtaining CE approval for the control system in its entirety. The installer must check that the installation of the PCB fulfils the requirement for the temperature range of the PCB.

- **Authorisation**

Persons installing the PCB in an enclosure must be trained and authorised for the particular task.

- **Enclosure**

The PCB must be installed in an enclosure designed for the surrounding environment, and must protect the electronics from moisture, dust and contact.

The enclosure must provide protection to class IP54 or better and must be designed for screw fixing to a wall or bracket.
 For outdoor use, or if there is a risk of condensation in the enclosure, a heating element must be used.

- **Installing the PCB**

The PCB must be secured to a metal plate. The PCB dimensions are shown below.

Use the screws, spacers and washers provided to fix the PCB as illustrated.

If the fixing plate is painted, scrape off the paint around the holes to ensure good contact between the earth bar, spacers and the plate.

Fit the earth bar to the fixing plate, for connecting the external earth.

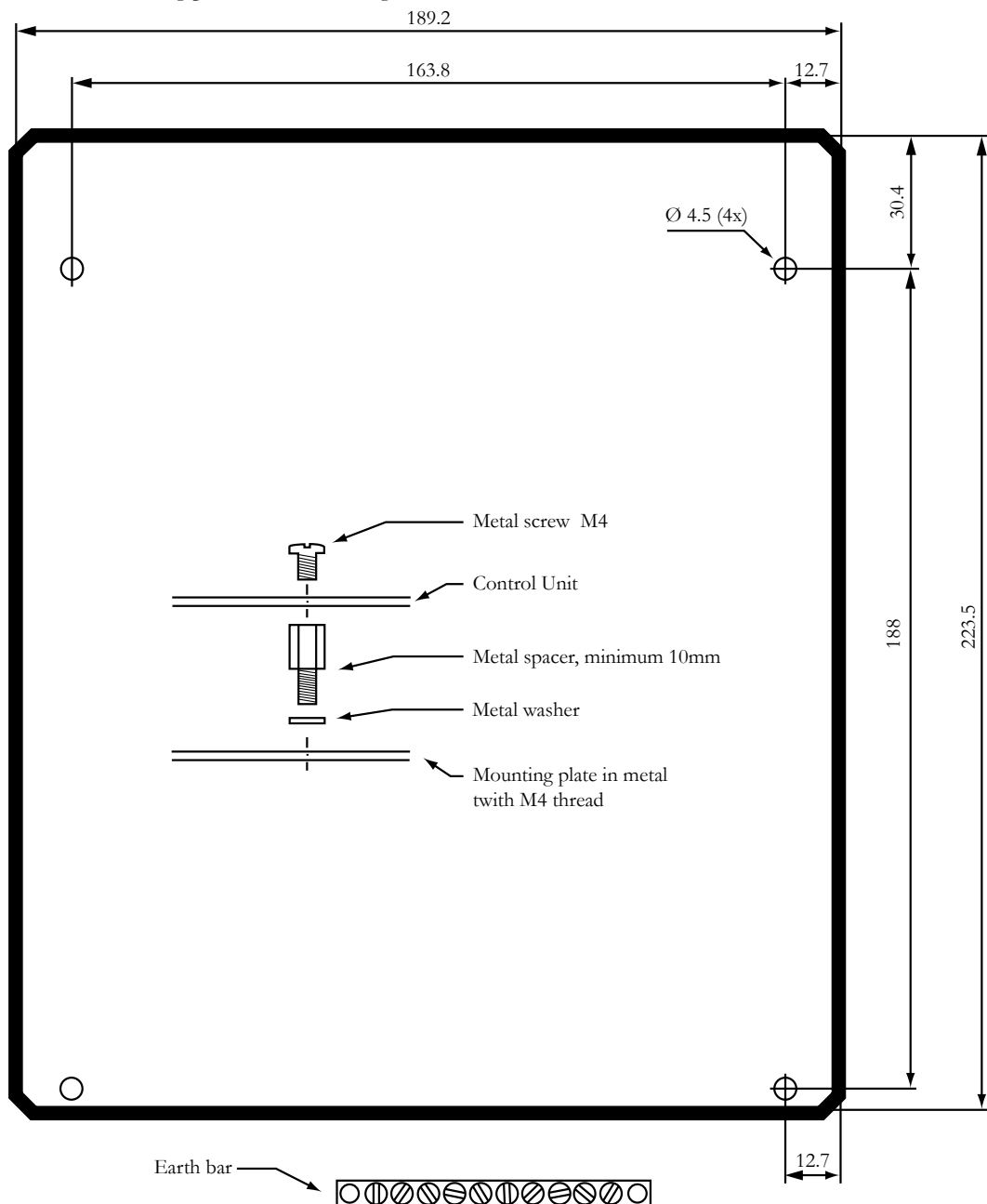

• Connecting a safety edge

The safety edge resistor must be installed in the safety edge so that an open-circuit in the resistor or the cable is interpreted as actuation of the device. See the wiring diagram below. SE.C1 and SE.O1 must be used for a safety edge connected to the half to which motor 1 is connected, and SE.C2 and SE.O2 to the half to which motor 2 is connected.

The impedance can be between 1.0-9.9 kΩ with a 1% tolerance and a power capability of at least 0.5 W. FAAC Nordic AB recommends an impedance of 8.2 kΩ. A safety edge can only be connected in series.

When connecting in series, only one resistor is used in the outermost safety edge, as shown in the wiring diagram below. The maximum number of safety edges connected in series with an impedance of 8.2 kΩ is six per input.

Note that the impedance used for a safety edge must be checked and entered into the EP105 on commissioning, see Commissioning below.

 Other types of impedance safety edge must not be connected directly to the safety edge inputs – they require an external control unit.

See the instruction manual for these safety edges.

Use only safety edges approved by FAAC Nordic AB.

• Connecting safety edges and photocells

The diagram below illustrates how to connect an external safety edge unit.

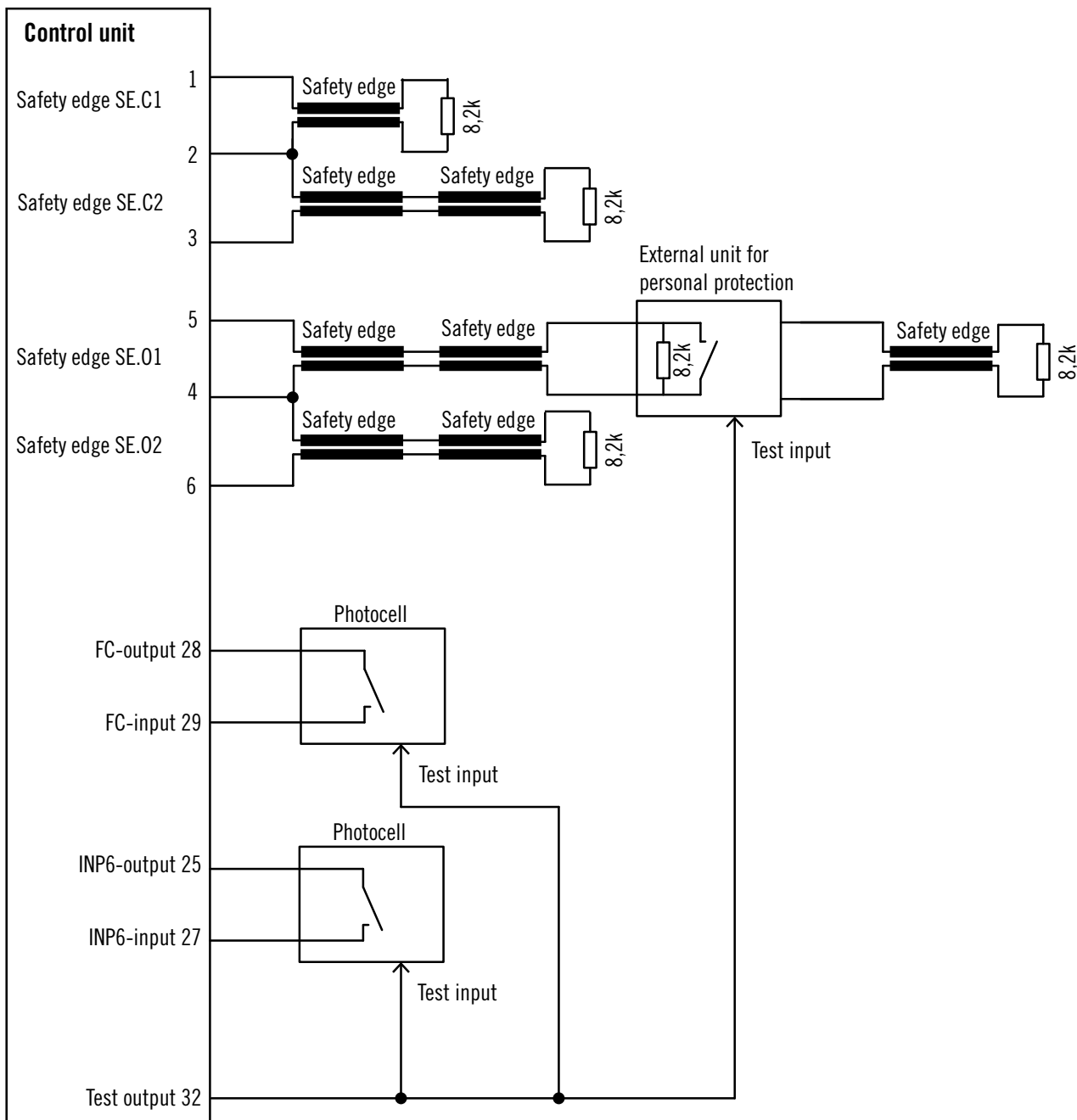

• Connecting an encoder (electronic limit switch)

The EP105 supports DB405 type encoders. The encoder uses the same terminals as a conventional mechanical limit switch. The two diagrams below illustrate how to connect the encoder, and also show which is the left and right motor from the point of view of the automatic control unit. Make sure the cable to the encoder does not share the same buried pipe as the motor power supply.

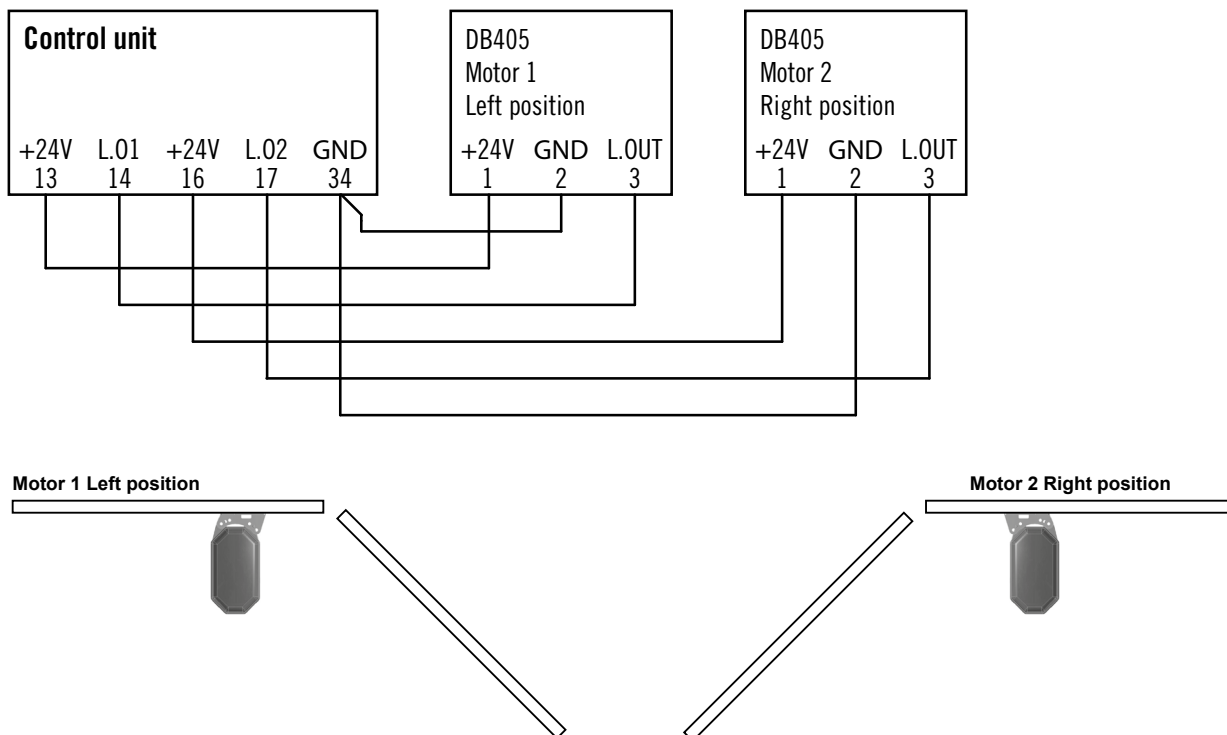

• Connecting a mechanical limit switch (microswitch)

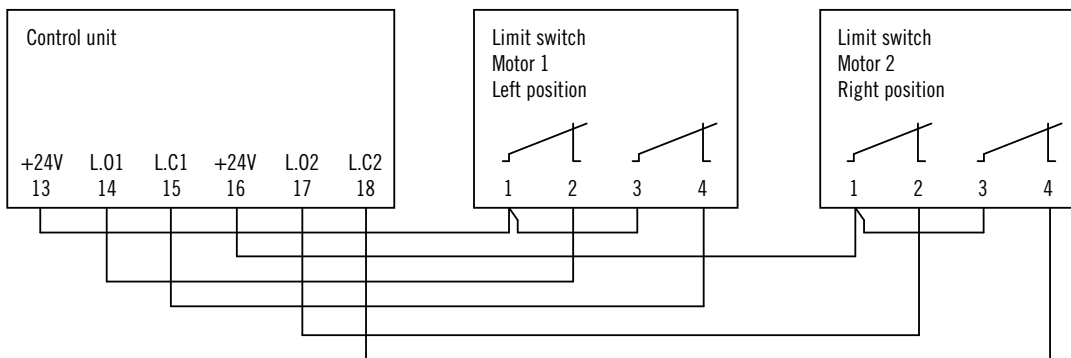

• Connecting timer control limit switches

Limit switches can still be used with timer control – they are connected as shown above (mechanical limit switch) but only for the open position. If there is no limit switch, make the connections as shown below. A mechanical stop in the open position must be fitted.

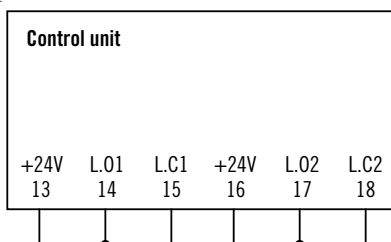

Configuring the EP105

This section provides general instructions on how to change settings in the EP105.

Remember to discharge any static charge in your body by always touching an earthed connection before starting installation.

• General

All values are stored according to a list of channels (in the channel reference), with each channel corresponding to a particular control parameter or value in the EP105.

The display can show a value up to four digits long, or a channel number with the prefix C, d, F, L, o, P or r, followed by three digits.

The display can be used to show values as well as change settings – the value flashes while the setting is being changed.

If E appears followed by a number, this is an error message – see "Error messages". Note that the startup values "EP-1" and "EP-2" are not error messages. When the power is connected, EP-1 appears when the unit controls one motor, and EP-2 when the unit controls two motors.

The <J button switches between the value and the channel number and, in configuration mode, it saves the value.

The + button scrolls up the channel list in channel mode. In configuration mode, the button increases the value.

The - button scrolls down the channel list in channel mode. In configuration mode, the button reduces the value.

If no button is pressed in 90 seconds, the display switches to economy mode with reduced brightness. Press any button to return to normal mode.

Display	Description
C _{nnn}	Channel number for the EP105
d _{nnn}	Channel number for the vehicle detector
F _{nnn}	Channel number for the frequency converter
L _{nnn}	Channel number for the limit switch
o _{nnn}	Channel number for the output card
P _{nnn}	Channel number for programmable inputs
r _{nnn}	Channel number for the wireless card
E _{nnn}	Error message (not EP-1 and EP-2)
r _{nnn}	Message
nnnn (flashing)	The channel value is changed but not saved

Button	Description
+	Button to increase the channel or value
-	Button to decrease the channel or value
<J	Switch between channel number and value
<J	Save/confirm the changed value
(↻)	Switch between different channel groups

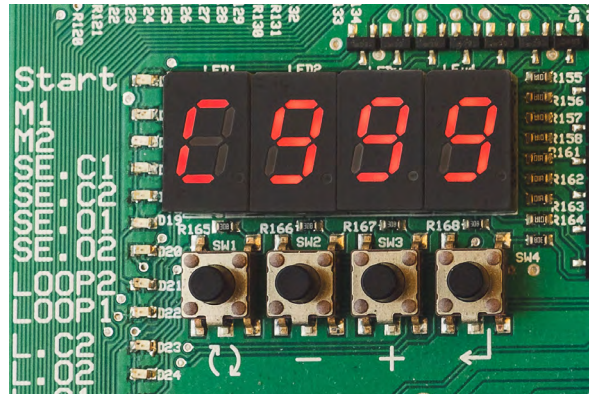

• Readout of parameters in the EP105

Press the <J button so the display shows the channel number – a letter followed by digits.

Press the (↻) button to quickly change between letters (channel groups).

Press the + or - button to step to the channel number you want.

Press the <J to show the value on the display.

Press the <J button again to exit and return to the channel number. Leave the unit in this mode – you cannot exit any further.

• Setting parameters in the EP105

Select the channel number according to the readout above.

Press the + or - button. The value starts flashing and is ready to be changed. Return to the original value by pressing the (↻) button.

Press the + or - button to step to the value you want.

Press the <J button to save the value.

Press the <J button again to exit and return to the channel number. Leave the unit in this mode – you cannot exit any further.

- **Locked settings**

Settings in the different channels can be locked by service personnel so that they cannot be changed. Contact an authorised service engineer, who will have the instructions needed to release the unit for configuration.

- **Configuration channels C700 - C712**

It is indicated in channel C700 in which application the control will work. There are three main alternatives, gate, door and road barrier. The subsidiary options are swing, folding or sliding gate or door

It is indicated in channels C701 to C712 which add-in cards are installed. The settings here control to some extent which channels will be displayed.. If, for example, C707, DB407 output card, is set to 0, none of the o-channels will be shown. The settings in C700 do not affect the channel display.

- **Message channel C904**

To facilitate troubleshooting, it is possible choose via channel C904 to display and save in the error code list various events beyond the error messages. If, for example, safety edge SE.C1 is activated so that reversing takes place, a message, n042, will be displayed and saved. The message disappears automatically from the display after about a second, but is saved in the error code list in C903.

- **Display channel C999**

By entering different values in the display channel, EP105 will switch between different sets of channels. After power on, C700 is displayed as the first channel when C999 is set to 0 or 1. When C999 is set to 2, 3 or 4, C999 is displayed as the first channel.

With C999=0, all channels will be displayed.

With C999=1, channels that are changed in comparison with the factory setting are displayed.

With C999=2, channels for power supply, motor protection and limit switches are displayed. This display mode is used to set open and closed position.

With C999=3, channels are displayed for pulse/hold-to-run, safe edge, load guard, motor protection, ratio for frequency inverter, limit switches and application with add-in card. This display mode is used to set the load guard.

With C999=4, Displays channels for selection of application and add-on card. These channels are used to hide or show additional card channels.

- **Käyttöönotto C999-näyttökanavalla**

When a new EP105 is switched on for the first time, the C999 is set to 2. Now you can only step around among these channels using the plus and minus buttons:

C999, which is the first channel shown

L001, where the limit position for motor 1 is selected

L002, where the limit position for motor 2 is selected

C202, here you select the type of supply voltage

When the C999 is set to 2, you can easily select the supply voltage, set the motor protection and adjust the open and closed position. When you have selected the limit mode, channels for the selected limit mode type and for the motor protection are displayed.

When this is done, change the C999 to 3 and proceed with setting the impulse / holder, clamp protection, photocell and load monitor.

Finish by setting C999 to 4 and select in the channels C700 to C712 application and the additional cards you have connected to the controller.

Finally, you set the C999 to 0 and you now have access to all channels and can continue with the commissioning of any additional cards and fine-tune the function of the automatic control. In channel display mode, you can step fast using the left button.

See the sections "Quick guide for commissioning the swing gate" and "Commissioning" for more information.

• Signal list

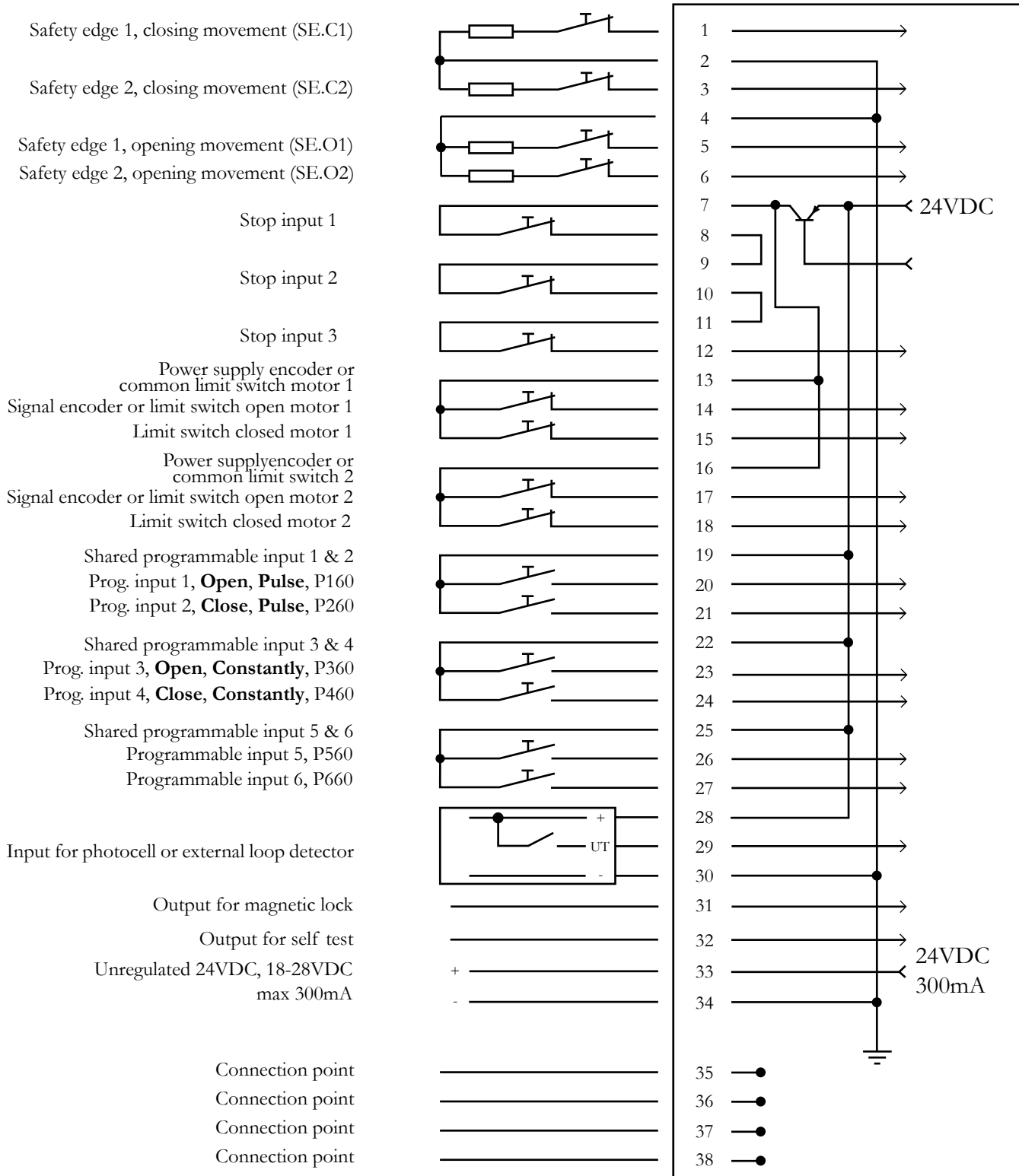

• Low current

The safety circuit, safety edge or limit switch must not be connected to, or used for, any other function. If signals from the EP105 are needed, a separate output card must be used.

The connection instructions are the same for all types of application, but not all signals may be needed.

If stop signals are unused, the associated input signals must be jumpered on the terminal block, see "Signal reference".

Note that the 24 V for the stop circuit must not be combined with other 24 V circuits.

- **Indications**

To simplify commissioning and troubleshooting, LEDs are provided to indicate faults and the status of input signals, as shown in the table below.

Colour	Indication	Active when
Yellow	START	A constant LED when control signal received, flashing LED when counting down for automatic closing. Slowly flashing when counting down channel C520.
Red	M1	A constant LED means that the load guard setting has been exceeded, and a flashing LED means that the load guard has been triggered for motor 1.
	M2	A constant LED means that the load guard setting has been exceeded, and a flashing LED means that the load guard has been triggered for motor 2.
	SE.C1	A constant LED means that the safety edge has been activated, and a flashing LED means that the safety edge has been reset.
	SE.C2	A constant LED means that the safety edge has been activated, and a flashing LED means that the safety edge has been reset.
	SE.O1	A constant LED means that the safety edge has been activated, and a flashing LED means that the safety edge has been reset.
	SE.O2	A constant LED means that the safety edge has been activated, and a flashing LED means that the safety edge has been reset.
Yellow	LOOP2	Vehicle loop 2 activated
	LOOP1	Vehicle loop 1 activated
	L.C2	Motor 2 not finished closing, extinguished in closed position, flashing means the input is not programmed, quick flashing means hold-to-run without limit switch
	L.O2	Motor 2 not finished opening, extinguished in closed position, flashing means the input is not programmed, quick flashing means hold-to-run without limit switch
	L.C1	Motor 1 not finished closing, extinguished in closed position, flashing means the input is not programmed, quick flashing means hold-to-run without limit switch
	L.O1	Motor 1 not finished opening, extinguished in closed position, flashing means the input is not programmed, quick flashing means hold-to-run without limit switch
Green	PHOTO	Photocell not activated, circuit closed
Yellow	OPEN	Signal from internal button – open
	CLOSE	Signal from internal button – close
	INP6	Signal on programmable input 6, closed circuit between terminals 25 & 27
	INP5	Signal on programmable input 5, closed circuit between terminals 25 & 26
	INP4	Signal on programmable input 4, closed circuit between terminals 22 & 24
	INP3	Signal on programmable input 3, closed circuit between terminals 22 & 23
	INP2	Signal on programmable input 2, closed circuit between terminals 19 & 21
	INP1	Signal on programmable input 1, closed circuit between terminals 19 & 20
Green	STOP	Stop not activated, safety circuit closed - OK
	SAFE	Electronics for the internal safety circuit is active - OK
Green	12 V	Voltage 12VDC - OK
	24 V	Voltage 24VDC - OK
Indications in top right-hand corner		
Yellow	CLOSE2	Contact for closing movement activated – motor 2
	OPEN2	Contact for opening movement activated – motor 2
	CLOSE1	Contact for closing movement activated – motor 1
	OPEN1	Contact for opening movement activated – motor 1

Applications

This section describes the settings required for various types of application. Type of application should be indicated in channel C700

- **Folding doors**

Load guard

When a folding door is commissioned, the load guard must be configured for personal protection. This means that it provides protection during the opening movement according to the applicable standards (obstacles while opening and also inside the folds). Personal protection means that a normal power is defined – the power used by the motor cannot fall below a lower limit or exceed an upper limit, calculated automatically by the system on the basis of the normal power. As a result, the load guard cannot be set higher than the normal effect, providing optimum protection during the opening movement.

Safety edge

There are usually two safety edges for a folding door, one for each half. They are connected to SE.C1 and SE.C2 and adjusted as described in the section on Safety edge. According to the factory settings, the safety edge inputs for opening movement, SE.O1 and SE.O2, are disabled.

- **Sliding doors/sliding gates**

Load guard

When a sliding door/gate is installed, the load guard should be configured without personal protection. This means that the purpose of the load guard is more to protect the motor and other mechanisms from damage. The load guard does not therefore provide effective protection for the opening movement if the door is opened against an obstacle with a crush risk.

Safety edge

Up to two safety edges are used in a sliding door/gate – one at the front and possibly one at the back. More than one safety edge is usually fitted to sliding gates to provide protection from crushing between the gate buffers and fixed objects like gate posts, drive units, etc. The safety edges fitted to the front provide protection for the closing movement, and those fitted to the back provide protection for the opening movement. Safety edges providing protection for the closing movement are connected to SE.C1 and SE.C2, while SE.O1 and SE.O2 are for the opening movement. Adjust the safety edge as described in the section on Safety edge. Note that according to the factory settings, the safety edge inputs for opening movement, SE.O1 and SE.O2, are disabled.

- **Up-and-over doors**

Load guard

When an up-and-over door is installed, the load guard should be configured without personal protection. This means that purpose of the load guard is more to protect the motor and other mechanisms from damage.

Safety edges

A safety edge for an up-and-over door must be set to send acknowledgements. This is a setting that is made in the EP105 by setting value 1 in channel C101 (C448 must be set to 0), safety edge acknowledgement. The safety edge is connected to SE.C1 and adjusted as described in the section on Safety edge. Note that safety edge acknowledgement only works with input SE.C1.

- **Swing gates**

Load guard

When a swing gate is installed, the load guard should be configured without personal protection. This means that purpose of the load guard is more to protect the motor and other mechanisms from damage. The load guard does not therefore provide effective protection for the opening movement if the gate is opened against an obstacle with a crush risk.

Safety edges

There are usually two safety edges for a hinged gate, one on each side. They are connected to SE.C1 and SE.C2 and adjusted as described in "Safety edge". If no safety edge is used for the opening movement, SE.O1 and SE.O2 are disabled.

- **Barriers**

Load guard

Load guards on barriers are only intended to protect the barrier and other mechanical components, so they are configured without personal protection. This means that the barrier changes direction in the presence of a high load in either direction.

Safety edge

A barrier usually has no safety edge at all – in this case, disable SE.C1, SE.C2, SE.O1 and SE.O2. Otherwise, adjust the safety edge as described in "Safety edge".

Quick guide to commissioning of swing gate

- Conditions

Electrical installation has been carried out and drive units are disconnected. Commission one drive unit at a time only and start with drive unit 1. The supply voltage in C2020 is set to 0, 3x400V with neutral. The limit switch is of the encoder type. The display channel C999 is set to 2. The indications for safety edge are unlit. The indications for photocell, stop circuit and 24V are lit green.

- Commissioning of drive unit 1

Direction of movement: Start L001 to 4, hold-to-run without limits. Check that the motor arm attachment is running in the right direction by pressing the OPEN or CLOSE buttons on the automatic control unit. For change of direction of rotation, see section on Connection in EP105 Instruction Manual.

Open and closed position: Connect the gate half to drive unit 1 and enter the positions for open and closed. After this, L001 is set to 1, encoder.

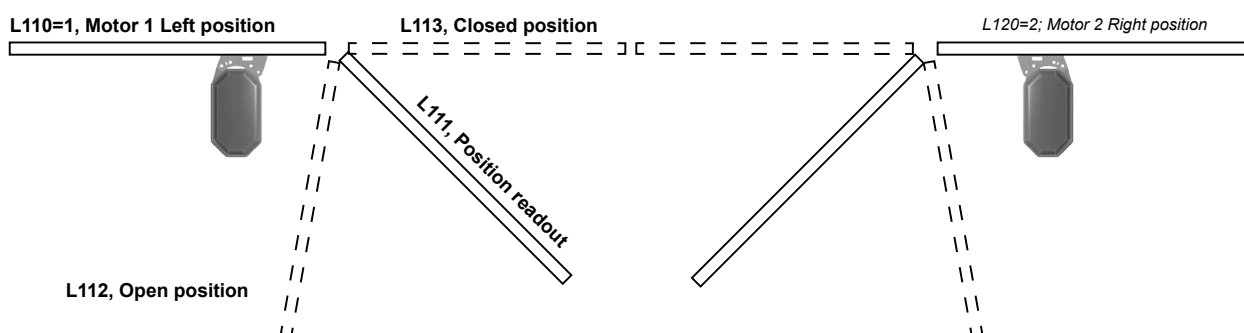

Motor protection: Read the motor current during operation in C251 and enter this value in C252 for opening and in C253 for closing. E201 means that the entered value is set too low. E206 means that the entered value is set too high.

Load guard: Set C999 to 3. In a hinged gate application personal protection is not normally required, and C230 is set to 0.00. Set C033 to 3, pulse to activate the load guard. After the load guard has tripped, the indication M1 flashes and the message n071 or n072 is shown on the display and in the error code list in C903. Check that the setting in the load guard in C232 and C233 is just high enough not to cause material damage, but at the time is so high that it is guaranteed to open depending on weather conditions and mechanical changes.

Safety edges: Check the safety edges on gate half 1 by pressing on the safety edges during movement. Note that safety edge function in opening is closed in C131. In activated safety edge during closing, the gate must reverse to the fully open position, while in opening it must reverse to closed position during the time in C494. Flashing indication for SE.C1 or SE.O1 means that the safety edge has been activated, but is now disabled.

- Commissioning of drive unit 2

Preparations: C999 is set to 2. Open half 1 and set L001 to 0 to keep drive unit 1 in open position Set C033 to 5, service position.

Direction of movement: Start L002 to 4, hold-to-run without limits. Check that the motor arm attachment is running in the right direction by pressing the OPEN or CLOSE buttons on the automatic control unit. For change of direction of rotation, see section on Connection in EP105 Instruction Manual.

Open and closed position: Connect the gate half to drive unit 2 and enter the positions for open and closed After this, L002 is set to 1, encoder.

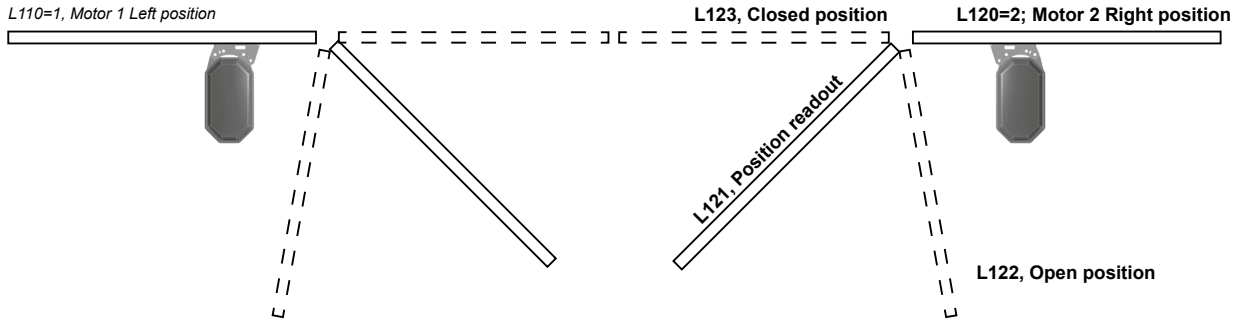

Motor protection: Read the motor current during operation in C261 and enter this value in C262 for opening and in C263 for closing. E202 means that the entered value is set too low. E207 means that the entered value is set too high.

Load guard: C999 is set to 3. In a hinged gate application personal protection is not normally required, and C240 is set to 0.00. Set C033 to 3, pulse to activate the load guard. After the load guard has tripped, the indication M2 flashes and the message n073 or n074 is shown on the display and in the error code list in C903. Check that the setting in the load guard in C242 and C243 is just high enough not to cause material damage, but at the time is so high that it is guaranteed to open depending on weather conditions and mechanical changes.

Safety edges: Check the safety edges on gate half 2 by activating the safety edges during movement. Note that safety edge function in opening is closed in C141. In activated safety edge during closing, the gate must reverse to the fully open position, while in opening it must reverse to closed position during the time in C494. Flashing indication for SE.C2 or SE.O2 means that the safety edge has been activated, but is now disabled.

Additional boards: Set C999 to 4. Channels C702 to C712 show or hide channels for additional boards.

If e.g. DB407, Output board, to be used set C707 to 1

Finishing: Set C999 to 0, display of all channels Set L001 to 1, encoder and make find adjustments to the gate halves in closed position using L113 and L123. Note all channels in EP105 Instruction Manual and the Log Book.

Commissioning

The process is the same for EP105-1 for one drive unit and EP105-2 for two drive units.

The settings are changed as described in the section "Configuring the EP105".

An E on the far left of the display indicates an error message, see "Error messages". Note that the start-up values "EP-1" and "EP-2" are not error messages.

Carry out the commissioning steps in the order shown – this will ensure that the channels are configured in the correct sequence.

The automatic control unit is supplied in service mode with hold-to-run. Hold-to-run means that the motor runs while the button is pressed, and stops when it is released.

The control unit will only work correctly if the following steps are carried out:

• Safety



Anyone commissioning the EP105 must have proven familiarity with, and understanding of, its functions, as well as experience of commissioning control systems for the application to be used.



See "Settings" to find out how to read and configure values in the EP105.

Check that:

- All equipment is mechanically secured and installed according to the applicable instruction manuals.
- All components are correctly connected and installed by authorised installers before switching on the power supply.
- The necessary safety measures are in place to remove the risk of crushing and other risks relating to the controlled unit.
- Any necessary decoupling devices are installed in the controlled unit and that they work as intended.

Make sure you:

- Discharge any static charge in your body by first touching an earthed object, for example the earth connection between the door and the control unit, before changing settings or doing other work on the EP105.
- Take care when operating internal buttons to avoid touching live parts.

• Stop circuit

The stop circuit consists of a safety output, stop buttons and contactors. If the control unit detects a fault during the self test, the power to the contactors is interrupted. The stop buttons are connected in series with the contactors, and they interrupt the power to the contactors. If the STOP indication is lit green, the stop circuit is closed.

• Frequency converter

If the system is controlled using frequency converters, it must be operated according to the operating instructions for DB409 before you can continue with limit switches.

• Limit switches

Limit switches are used to inform the unit when the door is in the open or closed position. There are three limit switch options to choose from: Encoders, which are electronic limit switches that detect the exact position of the door in degrees; mechanical limit switches using cams that control microswitches; or, if the motor does not have any physical limit switches, timer control.

Encoder (electronic limit switch)

Right/left encoder position

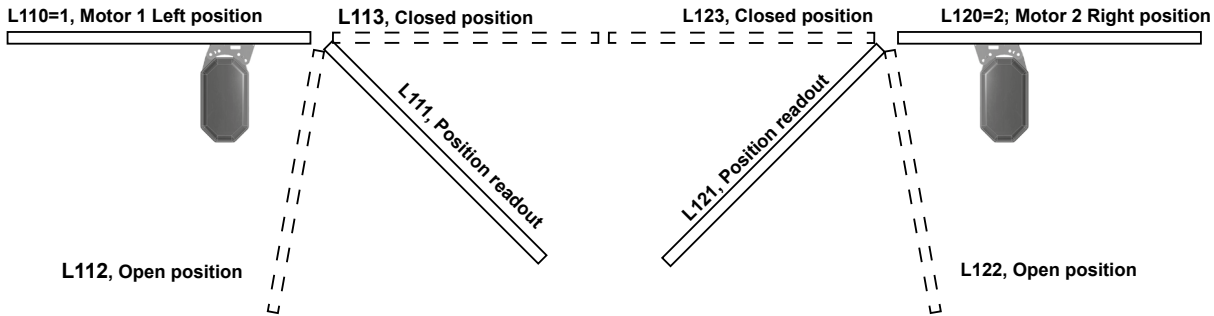

The encoder works by detecting the position of the door, and acts as an intelligent limit switch. Using a magnetic proximity sensor, the EP105 calculates the precise position of the door. Limits for open and closed can be configured directly in the automatic control unit in degrees instead of physically changing limit switch cams in the drive units. It is possible to commission one motor at a time by activating only one limit switch at a time. If L001 or L002 is set to 0, this motor will not turn and the indicator will flash. If L001 or L002 is set to 4 (not both at the same time) and C033 is set to 5, it will be possible for the motor to operate in hold-to-run with restrictions, and the limit switch indicators will flash quickly. L110 and L120 must be selected to be able to read the angle positions in L111 and L121. Note also that programmable inputs and radio are disconnected in this position. For a top-mounted drive unit, the motor is configured as for a right-mounted drive unit. See below for the side-mounted drive unit. Note that if the drive unit is installed upside down, the sides must be swapped because the motor runs in the "wrong" direction.

- Connect the encoder according to the instructions on page 13, "Connecting an encoder".
- Specify channel L001 as 4, hold-to-run without limit switch, then specify location of motor 1 in channel L110 where 1 is left and 2 is right. Keep the factory setting for L002 at 0
- Run the motor (hold-to-run) to the closed position, then read channel L111 for motor 1 and specify the value as closed position in channel L113 for motor 1. The value in L111 and L121 must always decrease when closing.
- Run the motor (hold-to-run) to the open position, then read channel L111 for motor 1 and specify the value as open position in channel L112 for motor 1. The value in L111 and L121 must always increase when opening.
- If two drive units are used, L001 is set to 0 and L002 to 4, in order to be able to run motor 2 in hold-to-run without limit switch. Then specify location of motor 2 in channel L120 where 1 is left and 2 is right.
- Run the motor (hold-to-run) to the closed position, then read channel L121 for motor 2 and specify the value as closed position in channel L123 for motor 2.
- Run the motor (hold-to-run) to the open position, then read channel L121 for motor 2 and specify the value as open position in channel L122 for motor 2.
- Then set both L001 and L002 to 1, encoder.
- Specify channel C033 as 0, hold-to-run with load guard inactive.
- Check that both halves open and close to specified positions.
- The limit switches are now configured and the motor will stop at the specified degrees. Note that some fine tuning may be necessary depending on the type of door and if there is motor slippage.

Mechanical limit switches (microswitches)

If conventional mechanical limit switches are used, the unit is configured as follows.

- Set channel L001 to option 2 for mechanical limit switch.
- Set channel L002 to option 2 for mechanical limit switches if there are two motors.
- Adjust the limit switch cams so they match the open and closed positions of the door. The easiest way to do this is to move the door to the end position and adjust the cam so that it activates the limit switch.
- Fine adjustment can be done using the run-on times in channels L212, L213, L222 and L223.

Time control (without limit switches)

Drive units without a limit switch can use timer control instead. With timer control, you measure the actual opening time of the door and set the automatic control unit to operate the motors for that length of time. To configure the unit for timer control, use the following channel settings.

- Set L001 to 3 for timer control.

- Set L002 to 3 for timer control if there are two motors.
- Run the motor (hold-to-run) to the fully closed position, then run the motor to the fully open position.
- Read channel L311 for motor 1 and make a note of the value.
- Read channel L321 for motor 2 (if there is one) and make a note of the value.
- Set a time in channels L312 and L322 that is 20% longer than the readout time.

• Direction of rotation of motors

To reduce the risk of injury or damage, the door must be disconnected during commissioning.

Check that the motor is running in the right direction by pressing the open and close buttons on the automatic control unit. If the direction of rotation is wrong, change the phase sequence of the motor, see "Connection – high current".

• Setting of motor protection

Read the current consumption of each motor during hold-to-run operation in channel C251 for motor 1 and C261 for motor 2 – then set the motor current in channels C252 and C253 for motor 1 and channels C262 and C263 for motor 2. A typical value for a drive unit of type MK with motor size 0.37 kW is 0.8 A. A typical value for MT with motor size 0.25 kW is 0.4 A.

A set value of 0.0 does not mean that the internal protection for the motor is disabled and intended to be used for external connectors.

When a frequency inverter is used, the instructions in the user manual for the DB409 must be followed.

The illustrations show motor protection settings for motor 1.

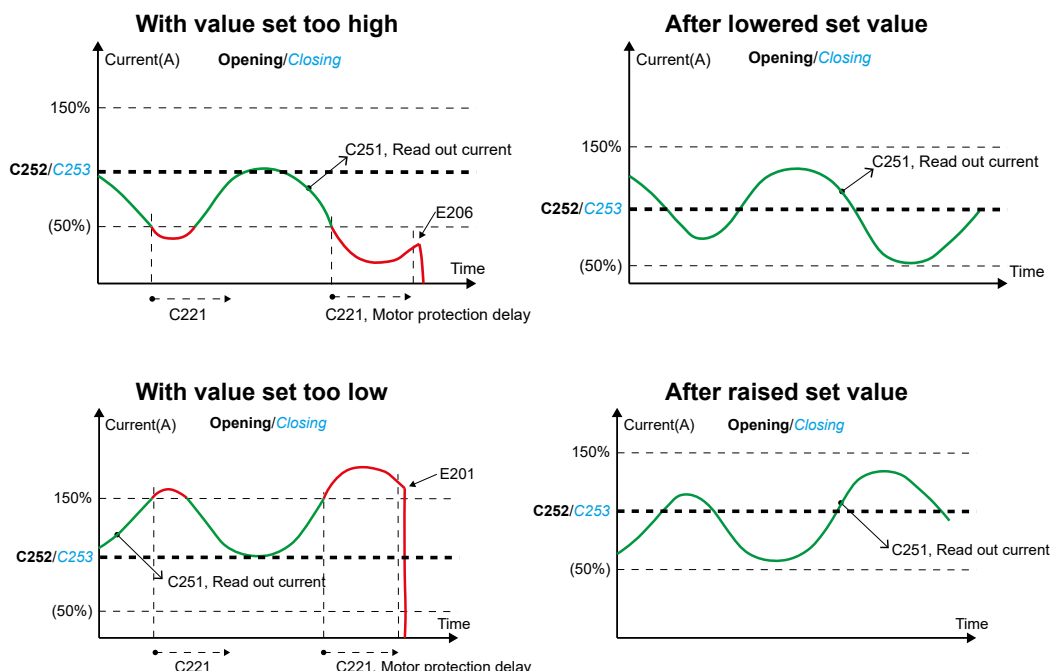

• Type of power supply

Only change this setting in high current installations with no neutral or a single-phase power supply.

The actual supply voltage is specified in channel C202.

The factory setting is 0, which means a supply voltage of 3x400 V+N+PE. For other options, see the channel reference.

Checking the phase sequence for 3x230 V without neutral

If there is no neutral, the load guard takes two phases as reference points, so the phase sequence must be correct.

To check that the phase sequence is correct, decouple the drive unit to allow the motor to run without load. With the motor running, read the value in channel C271 for motor 1 and C281 for motor 2 – the value should be about 0.20. If the phase sequence is incorrect, the value is about 0.95 and the load guard is activated.

See "Connection – high current" to find out how to correct an incorrect phase sequence.

• External protection units

The EP105 has a function to test external protection units. The test is run before every operation to ensure there are no problems with the safety edge unit. Only one safety edge unit with external testing can be connected to each safety edge input. To satisfy the safety requirements, the connected unit must have at least performance level C (PLc) in "EN ISO 13849-1 Safety of machinery - Safety-related parts of control systems". If the connected unit is a category 2 device, its test input must be connected to the test output of the EP105 (terminal 32). Note that the test output of the EP105 is connected to GND, +24V or set to high impedance (open), which can permanently damage units that are not designed to handle this. If a number of units are used, they are all connected to the common output signals for testing. Check with the unit manufacturer that this is permitted.

The EP105 is supplied without testing of the external protection unit for safety edges or photocells activated. When using external testing, activate by setting channels C102, C103, C113, C123, C133, C143, C343, P643. See channel list for specific settings.



Note that the factory setting of channel C102 is 0. To test external protection units, set C102 according to the manufacturer's instructions for the external protection unit.

Settings for external protection

Before changing the other settings, you will need the following information about the unit to be tested.

- Check supply voltage to which the unit will be connected.
- Check the required current – the maximum current for the 24 V DC of the EP105, terminal 33, is 300 mA, so an external transformer may be needed depending on what other equipment is connected.
- Check whether the external unit has an internal resistor at the output. If not, fit a 8.2 k Ω 0.5 W resistor to the output. FAAC recommends that this input should be short-circuited when the protection is activated.
- Check the active and inactive levels of the test input on the unit. Set C102 to the right polarity.
- Check that the impedance read off in the EP105 for the safety edge input to which the external unit is connected is correct.
- Check the resistance of the output of the unit when the test input is activated. Enter this into C103.
- Specify to which input, SE.C1, SE.O1, SE.C2, SE.O2, PHOTO or INP6, the external protection unit is to be connected. Do this via channels C113, C123, C133, C143, C343 and P643.

C102, controls how the test output works when external units are used with the test input according to the channel reference.

C103, indicates the resistance the safety edge inputs must have when the test signal is active. The procedure is the same for all inputs. For the photocell the voltage level is low and cannot be adjusted.



Make sure the system is serviced twice a year, even if external protection is used with daily function testing. Note that the test input only tests the external unit – not the safety edge/photocell connected to the unit.

• Load guard

The load guard can be used in two different ways.

- With certified personal protection – fixed upper and lower limits and adjustable normal power
- Without certified personal protection – an adjustable upper limit only

The automatic control unit is initially configured for certified personal protection. If the application requires certified personal protection with a load guard, you will need to check the normal power of the electric motor and enter it into the system.

If the application does not require certified personal protection with a load guard, you can disable the function by setting the normal power to 0. In this case, the load guard is not certified for personal protection.

In this mode, you can set your own upper limits for the load guard. There is an upper limit for the closing movement and an upper limit for the opening movement. The load guard will only work properly if the door and all moving parts are free to move easily throughout the entire movement.



Note that the load guard never replaces other safety circuits such as safety edges for example.

With certified personal protection – setting normal power in the load guard

The load guard is configured separately for each motor by reading the motor power during operation.

Read the normal power in C231 for motor 1 and C241 for motor 2. Change the normal power setting (initial value 0.20 kW) to the power used on average by the motor, in C230 and C240 respectively. The permitted range is 0.12-0.35 kW. The load guard will be activated when the load is 0.25 kW above the setting. Example: C230=0.20 kW means an upper load limit of 0.45 kW. There is also a lower limit so that it is impossible to set the normal power too high by mistake. This lower limit is 0.10 kW below the setting. Example: C230=0.20 kW means a lower load limit of 0.10 kW. In other words, personal protection will only work if the power used by the electric motor remains reasonably constant. The lower limit has a fixed delay of 4 seconds to prevent the load guard activating when the door is swinging shut, momentarily using insufficient power. The delay for the upper limit is in channel C211 and can be set at max. 0.06 seconds for personal protection.



The specified normal power applies to opening and closing movements.

If the fixed limits result in excessive crushing force, you can adjust the crushing force by reducing the limit settings in C232, C242 for the opening movement and C233, C243 for the closing movement. The initial value for these channels is 0.70 kW – you can reduce this value to a limit of your choice. In that case, the load guard is activated at the lower limit by the normal power setting (C230, C240) -0.10 kW and by the limit you set in C232, C233 and C242, C243. The values in the above channels must be less than the normal power setting 0.25 kW.

If the following criteria are not all met, doors that fold or open against solid walls can only be certified on safety grounds if other personal safety measures are used.

- The power read from the display must not exceed 0.4 kW for the opening and closing movements.
- The load guard delay in channel C211 is set to 0.06 seconds or less.
- The load guard connection delay in starts using channel C212 is set to 2 seconds maximum.
- The reverse delay following the activation of a safety edge or a load guard must not be set to longer than 0.2 seconds in C493.

Without certified personal protection – setting upper limits in the load guard



Set the normal power to 0.00 kW in channel C230 for motor 1 and 0.00 kW in channel C240 for motor 2.

With these settings, the load guard is not certified for personal protection.

There is no lower limit – only an upper limit for high load. Read the values in C231 and C241 and add 0.30kW. Specify this value as a default setting in C232 for opening and C233 for closing movement for motor 1, and in C242 and C243 for motor 2. Check that the crushing forces are not too high and not too low and that the door opens and closes without the load guard reversing or indicating overload, see Indications.

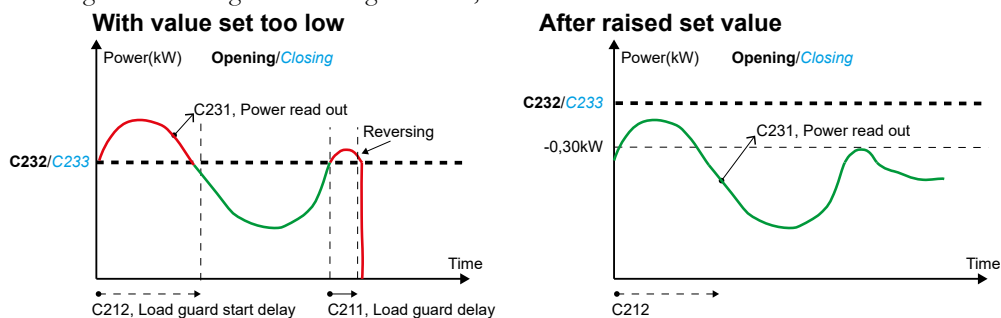

Reverse delay when the load guard is triggered

When approved personal protection is used, this time can be set at max 0.2 seconds, but without personal protection it can be set to max 2 seconds. Gentler reversing of the door can be obtained by increasing this time. Note that this time also applies with activated safety edge. Select channel C493 and set a suitable delay.



Be careful when increasing the delay in C493, as this may increase the crushing forces and negate the safety settings on which the type approval was based.

- Safety edges

Safety edge monitor

The integrated safety edge monitor in the automatic control unit performs a self test before the start of every movement. If any of the safety edges is faulty, the EP105 is stopped and an error is indicated. The principle is that the automatic control unit measures the impedance over the safety edge to ensure it matches a specified value. The impedance changes if the safety edge is activated, if there is a short circuit or if the circuit is interrupted – the automatic control unit interprets all these events as an activated safety edge.

LEDs indicate an activated safety edge with a constant light. If an activated safety edge has been disabled, the LED starts flashing and is extinguished the next time the door is operated in the direction in which it was activated.

 The safety edge monitor only works correctly if the stop circuit and the limit switch are connected as described in this instruction manual. See the sections "Low current" and "Signal reference".

Setting safety edges

The factory setting for safety edge in closing is fixed limits between 5 k Ω and 15 k Ω . If the safety edges used remain within these limits, no adjustment to safety edge impedance is necessary. If C111, C121, C131 and C141 are set to 2 for the safety edge concerned, the fixed limits are used. If you wish to specify safety edge impedance, set the channel concerned to 1 and specify safety edge impedance in C115, C125 and C135 for the safety edge concerned. To completely disable safety edge inputs that are not used, set C111, C121, C131 and/or C141 to 0 for the safety edge concerned.

- C111, setting for SE.C1
- C121, setting for SE.C2
- C131, setting for SE.O1
- C141, setting for SE.O2

0 = Disabled safety edge, factory setting for SE.O1 and SE.O2.

1 = Specified impedance for safety edge in C115, C125, C135 and C145 applies.

2 = Fixed limits for impedance, factory setting for SE.C1 and SE.C2.

Reading off the impedance value for safety edges

The impedance value for the safety edge can be read between 0.0 and 99.9 k Ω in the following channels:

- C114, impedance value for SE.C1
- C124, impedance value for SE.C2
- C134, impedance value for SE.O1
- C144, impedance value for SE.O2

Setting the impedance value for safety edges

The impedance value for the safety edge can be read between 1.0 and 9.9 k Ω in the following channels:

- C115, impedance value for SE.C1 if C111 = 1
- C125, impedance value for SE.C2 if C121 = 1
- C135, impedance value for SE.O1 if C131 = 1
- C145, impedance value for SE.O2 if C141 = 1



Note that the factory setting for SE.O1 and SE.O2 is that the safety edges are disabled.



Note that if you enter the value 0 in C111, C121, C131 or C141, the safety edge input is disabled.

A safety edge can only be connected in series.

When safety edges are connected in series, one resistor is used in the outermost safety edge. If the fixed limits would not work with the chosen resistor, set 1 in the channel concerned. You can read the current impedance value in channels C114, C124, C134, C144 and then check them against the values in the corresponding channels described above, depending on selected function.

Safety edge function

The principal functions of the three safety edge inputs are:

- SE.C1 for closing movement
- SE.C2 for closing movement
- SE.O1 for opening movement
- SE.O2 for opening movement

Connection and function, C104

In this channel a choice is made of whether a safety edge is to act on movement for one motor or on both motors.

In the case of EP104-1, all connected safety edges will act on a connected motor. In the case of EP104-2, it is possible to choose between letting a connected safety edge act on movement for both motors, C104=1, or only one of the motors, C104=2.

If C104-3 is chosen, the input SE.O2 will cause stopping in activation in both opening and closing. This function can be used for example to protect a door installed in the door leaf.

Safety edge functions – general

These settings are the same for a safety edge for the closing movement and a safety edge for the opening movement.

- Reverse/stop

In these channels you select whether the gate/door is to reverse or stop when the safety edge is activated.

- C112, selection of reverse or stop for SE.C1
- C122, selection of reverse or stop for SE.C2
- C132, selection of reverse or stop for SE.O1
- C142, selection of reverse or stop for SE.O2

1 = Reverse

2 = Stop

Option 1, Reverse, the unit will move in the opposite direction after a delay specified in channel C493.

 Option 2, Stop, stops the door without reversing. Must be used with care as the lack of the reverse function means someone may become trapped.

- Reverse delay.

The delay between activated safety edge and when the change of direction begins may be set in channel C493.

Safety edge function in the closing movement

On delivery and after a factory reset, the EP105 is configured to reverse to the fully open position when the safety edge is activated in the closing movement.

Safety edge function in the opening movement

On delivery and after a factory reset, the EP105 is configured to reverse when the safety edge is activated in the opening movement.

Reverse does not take place to the closed position, but during the time specified in C494.

Low speed after safety edge activation (Only when using a frequency inverter)

Using this setting the gate can be allowed to close slowly if it has reversed due to a safety edge. This is to prevent it closing on any remaining obstacle with full force. Set C105 either to 0 to deactivate the function or 1 to activate it, bearing in mind that this is only possible when using a frequency converter.

Performance testing safety edges

Check that the automatic control unit reacts as intended as configured above when the safety edge is activated.

Check that the LED indicates activated safety edges SE.C1, SE.O1, SE.C2 and SE.O2 with a constant light. Also check that the safety edges flash when they are no longer activated.

☞ Use L001 and L002 to disable one or the other motor by specifying 0 in one of these channels.

- **Input for photocell**

Terminal 29 can be used for photocell or vehicle loop via a control unit. The photocell can advantageously receive power from terminals 28 and 30, see Signal list section. The indication for this input is marked PHOTO, see section on Indications. If two units are to be used at the same time on this input, these must be connected in series via potential-free contacts with normally closed function.

Input for photocell in closing movement

When a vehicle passes the photocell or vehicle loop during the closing movement, the door usually reverses to the fully open position. To prevent a vehicle opening the door to fully open in this way, the door can instead stop, to prevent passage. To then close after an automatic closing time, C340 is set to 2 and C500 to a suitable delay.

Input for photocell in opening movement

If a vehicle passes the photocell while the door is opening, nothing usually happens. It is possible to set the door to stop instead, then close after the automatic closing time when the photocell is clear. However, this setting would prevent reverse in response to an activated photocell during the closing movement.

The door can either close again when the photocell or vehicle loop is clear, or stop while the photocell is activated and then close when the photocell is clear, according to the setting in channel C342.

Programmable input 6 configured for photocell

There is also an option for an extra input for photocell or vehicle loop by using terminal 27, and changing P600 to 2. Set the desired safety function in P640, P641, P642 and P643. The indication for this input is marked INP6, see section on Indications.

- **Limited running time**

If the limit switches have been selected in L001 or L002, a channel is displayed for limited running time, L203. Limited running time is used to protect the equipment against possible damage when the door or gate does not reach the open or closed position because of some fault. Limited running should be set to a slightly longer time than the normal running time for opening and closing.

In hold-to-run mode there is no limited running time, so this is a good way of measuring the running time.

Use hold-to-run mode to operate the door from fully closed to fully open and the other way around, read off and note the running times from L211 for motor 1 and L221 for motor 2. Select channel L203 and enter a value about 3 seconds longer than the longest time measured. If too short a time has been specified in L203, the error code E003 is displayed when the time in L203 has passed and the control unit stops the movement.

When encoder has been selected in both L001 and L002, L203 is not displayed as it does not need to be set either.

- **Checking LED indications**

Before continuing the commissioning process, check that all LEDs are working correctly as described in Indications. If there is a problem, review the connection instructions and check the connections. If the problem is still not solved, see "Troubleshooting" to find out what to do next.

- **Pulse mode and hold-to-run mode**

Hold-to-run mode means that the button has to be kept pressed to open or close – when the button is released, the motor stops.

In pulse mode, pressing and releasing the button opens or closes the door automatically. Pulse mode can be configured for either direction. Pulse mode must be active for automatic operation of the door.

Note that the applicable directive does not allow wireless transmitters to operate in hold-to-run mode, and wireless transmitters therefore do not work in hold-to-run mode. Pulse mode always applies with wireless transmitters.

Selecting pulse mode or hold-to-run mode

Select channel C033 and set the function you want.

Example 1: To set pulse mode for both opening and closing movements, set the value to 3.

Example 2: To set pulse mode for the opening movement and hold-to-run mode for the closing movement, set the value to 1.

Example 3: Set value 5 to put the automatic control unit into service mode. This means that no external control signals can be used. This results in safer working, as the system cannot be operated in any other way than with the card's internal buttons. It is also used for force-run without a functioning limit switch or encoder. Only hold-to-run works in this mode. Either L001 or L003 must be set to 4 in this mode. If encoder is used, L110 and L120 must also be selected for the display in L111 and L121 to be correct.

Hold-to-run if there is an error in the safety edge or PHOTO input

If the safety edge, photocell or vehicle loop is faulty, the automatic control unit automatically switches to hold-to-run mode in the direction in which there is a fault. Even when the safety edge or photocell/vehicle loop are activated, you can still open and close the door by keeping the button on the PCB pressed. As long as the control button is held down, the gate will open or close.

- **Checking safety functions**

When the automatic control unit has been commissioned, all the safety functions should be checked to make sure they work as intended. Take the drive units into operation again by recoupling and checking the following functions:

- Check that the safety edges work as desired, first on motor 1 and then on motor 2.
- Check that the load guard is activated under abnormal load.
- Check that the photocell (if there is one) is working.
- Check that the vehicle loop (if there is one) is working.
- If all the points above are OK, continue with commissioning. Otherwise return to the relevant section and check the settings. If this does not help, see "Troubleshooting".

- **Setting electric motor braking**

This function causes the motor to change direction for a short time when the limit switch is activated, so that a direct stop is obtained instead of slippage.

Electric motor braking only works on 3-phase drive units and does not work on control units with a frequency converter or single-phase drive unit. To set the control unit to this mode carry out the following:

- Adjust encoders or limit switch cams so they match the open and closed positions of the gate.
- Configure the braking time in C495 for motor 1 and C496 for motor 2. On light sliding gates the value should be 15-20 milliseconds. The value should be selected as low as possible, but sufficiently high for the desired braking force to be achieved. This is to protect the mechanism in the gearbox.

• Programmable inputs, P channels

There are six programmable inputs available in the EP105.

The instructions are identical for all six programmable inputs, apart from the channel number – input 1 has channel number P1nn, input 2 has channel number P2nn, etc. The settings below are for input 1.

Activate input 1 by setting P100 to 1. Note that the indication for the programmable input works even if the input is disabled. The following channels are used to set the function for the programmable input.

P160, Control function

Option 0 disables the control function on the programmable input, 1 is for the opening function, 2 is for the closing function, and 3 is for the stop function. Option 4 means open the gate if it is not already open, then close it as soon as it is in the open position. Option 5 means open, stop and close alternately. Five seconds after the last command, the next command is automatically set to open again.

P161, Type of control signal.

Use this channel to specify whether you want the signal to be a constant signal throughout the signal duration or just for the on flank (the automatic control unit interprets the signal as a pulse). If the pulse option is set, hold-to-run does not work if the safety edge is defective but the door can be operated via another input even if the input is activated.

P162, Half operation

To only open motor 1 set the value to 1, to only open motor 2 set the value to 2, and to open both motors 1 and 2 set the value to 3.

P163, Limited opening

With set value 0, the door opens to its end position, at set value 1 the door opens with encoder the number of degree specified in L116 and/or L117 or with limit switch, during the set time in L216 and/or L226.

P170, Motor lock.

When the value is set to 1 the door will start opening or closing when there is a signal on the input and another input is controlled. This is to ensure that the motor lock is unlocked before opening or closing takes place.

P175, Delayed opening

The motors will not start the opening until the input has been activated for a set time. This may be used, for example, to prevent unintended opening signals.

P180, Park

Use this channel to park the door. Option 0 disables the function, option 1 parks the door in the open position and waits for a new control signal before the door is closed. To use a timer for parking and opening the door, set P160 to 1 and P180 to 2. The input will then send a command to open the door in response to a signal, and keep the door open for as long as there is a constant signal at the input.

P190, Interlock opening

Use this parameter with the value 1 if you want the input to open a local door and also forward the open signal to a remote door.

P196, Blocking disabled for local and remote doors

Set the value to 1 to disable blocking for the local and remote doors.

P198, Automatic closing disabled for local and remote doors

Set the value to 1 to disable automatic closing for local and remote doors.

• Automatic closing

To prevent the door being left open, you can configure the unit to close it automatically after a specified period. Any time from 0.1 to 600.0 seconds can be chosen. The timer starts when the door has stopped moving. If any control input or safety device is activated in the closing direction, the timer is stopped and the time starts counting from the set value again.

If you use automatic closing, it is a good idea to connect a wireless transmitter or a pull cord to an unused input. This is to allow passing users to send a new opening signal and reset the automatic closing time.

You can use programmable inputs and a timer to disable automatic closing at particular times of the day. The time remaining until automatic closing takes place can be read off in channel C019.

Configuring automatic closing

Choose channel C500 and set a suitable time between 0.1 and 600.0 seconds before automatic closing takes place. Note that only times with whole seconds can be indicated between 10.0 and 600.0. 0.0 means that automatic closing is disabled.

Stop function

The automatic control unit has an adjustable stop function. The function applies to the normal stop buttons and also the stop function in programmable inputs. The initial setting is that when the stop button is pressed the countdown for automatic closing does not restart.

Automatic closing after stop

All control signals except stop and power failure restart the countdown for automatic closing. This means that automatic closing is not affected in the event of a stop signal. This applies to conventional inputs and to programmable inputs.

If you want the countdown to restart automatically even after stop has been activated, you must set a delay in channel C520 and C500.

Select channel C520 and set a 20 - 600 seconds delay for automatic closing after stop has been activated. Set the value to 000 to disable automatic closing.

Automatic closing after photocell activation

This function enables automatic closing after a photocell is activated.

Use channel C351 to activate the function.

Select channel C351 and set the value to 1 to activate or 0 to deactivate.

Use channel C354 to specify how the door closes once the photocell is no longer activated.

Select channel C354 and set the value to 1 to close immediately, or 2 to close only after opening fully.

To delay closing after photocell activation, select channel C510 and set a time between 0 and 99 seconds.

Note that the delay configured in channel C510 is also used for automatic closing after the vehicle loop is activated.

If the photocell is not activated, automatic closing occurs as described above.

Automatic closing after vehicle loop activation

This function enables automatic closing after the vehicle loop is activated. The function is present on both loops, but is shown below for loop 1.

To access the function, select channel d151.

Select channel d151 and set the value to 1 to activate or 0 to deactivate.

Use channel d154 to specify how the door closes once the vehicle loop is no longer activated.

Select channel d154 and set the value to 1 to close immediately, or 2 to close only after opening fully.

To delay closing after loop activation, select channel C510 and set a time between 0 and 99 seconds.

Note that the delay configured in channel C510 is also used for automatic closing after a photocell is activated.

If the vehicle loop is not activated, automatic closing occurs as described above.

Direction sensing for an internal closing pulse

Using channel C591 and the DB402 add-in card for vehicle loops, you can configure the internal close signal depending on the preferred direction sensing mode in LOOP1 and LOOP2 and the PHOTO input.

See the channel reference for all possible values.

• Run-on time with mechanical limit switches

The run-on time is the set time that the control continues to run the motor after the limit switch has been tripped. By making a rough setting of the mechanical limit switch, so that it trips earlier, the final position of the gate or door can then be finely adjusted using the run-on time. This avoids the need to climb up to the drive unit for fine adjustment of the limit switch. The run-on time can also be used if you want a door to close securely against the frame without triggering the load guard or safety edge.

To see how stop is to take place during the run-on time, see also the section “Stop function during run-on time in closing” below.

NOTE! The run-on time must never be set so long that there is a risk of the limit switch cam bypassing the limit switch.

Run-on time for closing

Run-on time means that when the limit switch in the closed position has been activated the gate or door continues closing during the set run-on time and the movement is then stopped. Choose channel L213 for run-on time in closing for motor 1 and channel L223 for motor 2.

Run-on time for opening

Run-on time means that when the limit switch in the open position has been activated the gate or door continues opening during the set run-on time and the movement is then stopped. Choose channel L212 for run-on time in opening for motor 1 and channel L222 for motor 2.

Stop function after run-on time in closing movement

There are two events that can activate the closing movement during run-on time. Either a safety edge is activated or the load guard trips. If neither of these occurs, movement will stop when the run-on time expires. What is to activate movement is controlled by the settings in C436, C448 and C449. Channel C436 determines if safety edge or load guard is to be able to stop a closing movement during the run-on time.

If C436 is set to 0, neither safety edge nor load guard will stop movement, and reversing or nothing will take place depending on the settings in C448 and C449. In both these channels 0 means that nothing happens in activation of safety edge or load guard, and the closing movement continues during the run-on time. If C448 and/or C449 are set to 1, the closing movement will reverse.

If C436 is set to 2, the closing movement will stop when safety edge or load guard are activated before the run-on time has expired, if the settings in C448 and C449 are set to 0 no reversing. If C448 and/or C449 are set to 1, the closing movement will reverse. With safety edge or load guard activated during the run-on time, reversing in channels C448 and C449 thus has higher priority than stop in C436.

Set C448 to 0 to allow the automatic control unit to be operated without the safety edge function during the run-on time. If C436 is set to 2, movement will stop when the safety edge is activated, but if C436 is set to 0 movement will continue until the run-on time has elapsed regardless of the safety edge. In this setting the limit switch cams will be adjusted so that the run-on time is reduced to as short a time as possible to prevent crush risk!

- **Run-on with encoder**

In use of an encoder the run-on times in L213 and L223 are not used and the final positions of the door or gate are instead adjusted directly in channels L112, L113, L122 and L123. Disengagement angle is used to disengage different protective functions. The disengagement angle is indicated in channels L117, L118, L127 and L128 depending on motor 1 or 2 and depending on what function is to be disengaged. The run-on times on opening movement in L212 and L222 can be used to produce a continued opening movement after the value in L112 and L122 has been reached.

Stop function during disengagement angle in closing movement

Stop function with an encoder works in similar way as for a limit switch, but disengagement angle is used instead to indicate at what angle, from closed position, the protection function is to be disengaged. See also “Stop function during run-on time in closing movement” above. NOTE! Channel C436 is subordinate to channels C448, C449, L117, L118, L127 and L128. Select channel C436 and choose the stop function you want during disengagement angle. The function specified in channel C436 is only active during the set disengagement angle for closing. Depending on the stop function configured in C436, it is possible, for example, to set the door to close tightly against rubber strips without triggering the load guard or safety edge. The disengagement angles are to be reduced to as small an angle as possible, to prevent crush risks.



Choosing disengagement angles that are too large may lead to a crush risk!

- **Reverse**

Reverse delay

To obtain faster or slower turning in change of direction, the time when the door changes direction can be adjusted. Use channel C492 to configure the reverse delay – either opening or closing – after the photocell or a vehicle loop is activated.

Select channel C492 and set a suitable delay. Note that when a frequency inverter has been selected in C202, channel C492 is not displayed, and the times specified in F005 and F006 instead apply to retardation.

Reverse priority

The automatic control unit is normally set to priority open, channel C063 = 1, which means that opening continues to the fully open position even if the close signal is given while the door is opening.

Important. The change of priority does not apply to the open/stop/close or open/close function in programmable inputs.

- **Priority open only**

When the open button is pressed during closing, the direction changes to opening.

When the close button is pressed during opening, nothing happens.

Select channel C063 and set the value to 1.

- **Priority close only**

When the close button is pressed during opening, the direction changes to closing.

When the open button is pressed during closing, nothing happens.

Select channel C063 and set the value to 2.

- **Priority open and close**

When the open button is pressed during closing, the direction changes to opening.

When the close button is pressed during opening, the direction changes to closing.

Select channel C063 and set the value to 3.

- **No priority**

Pressing the open or close button has no effect if the door is already moving.

Select channel C063 and set the value to 0.

Functions using add-in cards

Add-in cards can be installed in the EP105 for access to extra functions. DB407 and DB410 programmable outputs, DB402 vehicle detector, DB411 (the DBR1 system) for 4 programmable radio inputs, DB512 for interlock communication, and DB409 for motor control with frequency inverter.

Follow the instruction manual supplied with the add-in card when installing add-in cards in the EP105 and commissioning.

Channel list

There are seven channel categories, each with its own letter and each handling different functions in the card. Note that an explanation of d, F, o and r-channels is provided in the appropriate instruction manual

- C-channels: General readout and configuration channels.
- d-channels Channels relating to the DB402 vehicle detector.
- F-channels: Channels relating to settings for frequency converter, DB409
- L-channels: Channels relating to limit switches and timer control and the DB405 encoder.
- o-channels: Channels relating to output cards DB407 and DB410.
- P-channels: Channels relating to programmable inputs.
- r-channels: Channels relating to function of the DB411 radio card.

There is a reference column for each channel, showing where you can find more details and examples of how to use the channel, and the functions you can access with the channel.

Channels with a grey background are readout channels so they cannot be changed.

The  symbol means that the channel is a safety setting, and any change in value must be documented in the log book, with a name and date.

• General, C-channels

General readout channels

No.	Name	Range	Factory	Setting	Ref. page
C001	Software revision				
C004	Hardware revision				
C005	Voltage after stop circuit	00.0 – 30.0 V			
C014	Number of openings x1	000 - 999			
C015	Number of openings x1000	000 - 999			
C019	Time remaining to automatic closing	000.0-600.0 seconds			
C020	Most recent cause of motor stop				
	01	Limit switch motor 1 open			
	02	Limit switch motor 1 closed			
	03	Limit switch motor 2 open			
	04	Limit switch motor 2 closed			
	10	Stop			
	21	Photocell during opening movement			
	22	Photocell during closing movement			
	31	Loop 1 during opening movement			
	32	Loop 1 during closing movement			
	33	Loop 2 during opening movement			
	34	Loop 2 during closing movement			
	41	Safety edge opening reverse			
	42	Safety edge opening stop			
	43	Safety edge closing reverse			
	44	Safety edge closing stop			
	51	Photocell input 6 opening			
	52	Photocell input 6 closing			
	90	Loss of mains voltage			
	91	Low 24VDC			

General configuration channels

No.	Name	Range	Factory	Setting	Ref. page
▲ C033	Pulse/hold-to-run	0 - 5	5		29
	0	Open and close with hold-to-run and load guard inactive			
	1	Open with pulse and close with hold-to-run and load guard active			
	2	Open with hold-to-run and close with pulse and load guard active			
	3	Open and close with pulse and load guard active			
	4	Open and close with hold-to-run and load guard active			
	5	Service mode, only internal open/close buttons with hold-to-run. Enables L001/2 to be set to 4, operation without limit switch.			
C063	Reverse priority during movement	0 - 3	1		32
	0	None			
	1	Open			
	2	Close			
	3	Open and close			

Safety edge

No.	Name	Range	Factory	Setting	Ref. page
▲ C101	Safety edge acknowledgement SE.C1	0 – 1	0		18
	0	Disabled			
	1	Enabled			
▲ C102	Output for self-test of external protection	0 – 4	0		24
	0	Check disabled, open output.			
	1	Closed to GND on activation, normally open.			
	2	Closed to V+24 VDC on activation, normally open.			
	3	Open on activation, normally closed to GND.			
▲ C103	Function of safety edge input during test of external safety edge unit	1 – 2	1		24
	1	Low resistance during test			
	2	High resistance during test			
▲ C104	Connection and safety edge function	1 – 3	1		27
	1	SE.C1 or SE.C2 can be connected to either motor 1 or motor 2. SE.O1 or SE.O2 can be connected to either motor 1 or motor 2. Both safety edges reverse/stop an active motor			
	2	SE.C1 and SE.O1 must be connected to motor 1 SE.C2 and SE.O2 must be connected to motor 2 The safety edge function is attached to the motor concerned			
	3	SE.C1 or SE.C2 can be connected to either motor 1 or motor 2. SE.O1 can be connected for protection function in opening for motor 1 and motor 2. The safety edges reverse/stop an active motor SE O2 stops an active motor in both opening and closing and overrides channel C142			
C105	Halved speed after activated safety edge. Only when using a frequency converter.	0 - 1	0		27
	0	Disabled			
	1	Active			
▲ C111	Selects function for safety edge SE.C1	0-2	2		26
	0	SE.C1 disabled			
	1	Limits according to set value in C115			
▲ C112	Reverse/stop with activated safety edge SE.C1 (KSS)	1 - 2	1		27
	1	Reverse			
▲ C113	Control of external protection connected to SE.C1	0 - 1	1		24
	0	No check			
▲ C115	Setting impedance value for safety edge SE.C1 Set to 1 only at C111.	1.0-9.9 kΩ	8.2		26
	C114	Reading impedance SE.C1	00.0-99.9 kΩ		

No.	Name	Range	Factory	Setting	Ref. page
▲ C121	Selects function for safety edge SE.C2	0-2	2		26
	0	SE.C2 disabled			
	1	Limits according to set value in C125			
	2	Fixed limits between 5 kΩ and 15 kΩ			
▲ C122	Reverse/stop with activated safety edge SE.C2	1 – 2	1		26
	1	Reverse			
	2	Stop			
▲ C123	Control of external protection connected to SE.C2	0 - 1	1		24
	0	No check			
	1	Test of protection connected to SE.C2 if C102 is enabled			
C124	Reading impedance SE.C2	00.0-99.9 kΩ			
▲ C125	Setting impedance value for safety edge SE.C2 Set to 1 only at C121.	1.0-9.9 kΩ	8.2		26
▲ C131	Selects function for SE.O1	0-2	0		26
	0	SE.O1 disabled			
	1	Limits according to set value in C135			
	2	Fixed limits between 5 kΩ and 15 kΩ			
▲ C132	Reverse/stop with activated safety edge SE.O1	1 – 2	1		26
	1	Reverse			
	2	Stop			
▲ C133	Control of external protection connected to SE.O1	0 - 1	1		24
	0	No check			
	1	Test of protection connected to SE.O1 if C102 is enabled			
C134	Reading impedance SE.O1	00.0-99.9 kΩ			
▲ C135	Setting impedance value for safety edge SE.O1. Set to 1 only at C131.	1.0-9.9 kΩ	8.2		26
▲ C141	Selects function for SE.O2	0-2	0		26
	0	SE.O2 disabled			
	1	Limits according to set value in C135			
	2	Fixed limits between 5 kΩ and 15 kΩ			
▲ C142	Reverse/stop with activated safety edge SE.O2 Subordinate to channel C104	1 – 2	1		26
	1	Reverse			
	2	Stop			
▲ C143	Control of external protection connected to SE.O2	0 - 1	1		24
	0	No check			
	1	Test of protection connected to SE.O2 if C102 is enabled			
C144	Reading impedance SE.O2	00.0-99.9 kΩ			
▲ C145	Setting impedance value for safety edge SE.O2. Set to 1 only at C141.	1.0-9.9 kΩ	8.2		26

Load guard and motor settings

No.	Name	Range	Factory	Setting	Ref. page
▲ C200	Load guard function	0 – 4	3		25
	0	Disabled. Service and troubleshooting only			
	1	Reverse when closing, stop when opening			
	2	Stop when closing and reverse when opening			
	3	Reverse when closing and opening			
	4	Stop when closing and opening			
▲ C202	Type of power supply	0 - 5	0		16
	0	3x400V with neutral			
	1	3x230V without neutral			
	2	1x230V with neutral, asymmetrical			
	3	3x400 V without neutral (see separate instructions)			
	4	1x230V with neutral, frequency converter (See DB409)			
	5	1x230V with neutral, asymmetrical			
C205	Load guard for personal protection active during the closing movement	0-1	1		
	0	Disabled			
	1	Active			
▲ C211	Load guard delay	0.01-2.50 seconds	0.06		25
▲ C212	Load guard, connection delay on start, all starts	0.1-2.5 seconds	1.0		25
▲ C221	Motor protection delay	3.0-5.0 seconds	5.0		
▲ C230 ^{AC}	Set motor power readout for personal protection, motor 1	0.00 and 0.12-0.35 kW	0.20		25
C231 ^A	Motor power readout, motor 1	0.00-1.99 kW			
▲ C232 ^A	Set load guard limit for motor 1 opening	0.05-1.99 kW	0.70		25
▲ C233 ^A	Set load guard limit for motor 1 closing	0.05-1.99 kW	0.70		25
▲ C240 ^{BC}	Set motor power readout for personal protection, motor 2	0.00 and 0.12-0.35 kW	0.20		25
C241 ^B	Motor power readout, motor 2	0.00-1.99 kW			
▲ C242 ^B	Set load guard limit for motor 2 opening	0.05-1.99 kW	0.70		25
▲ C243 ^B	Set load guard limit for motor 2 closing	0.05-1.99 kW	0.70		25
C251 ^A	Motor current readout, motor 1	0.0-20.0A			
▲ C252 ^A	Set motor current readout, motor 1 opening	0.0 and 0.5-6.0A	0.8		25
▲ C253 ^A	Set motor current readout, motor 1 closing	0.0 and 0.5-6.0A	0.8		25
C261 ^B	Motor current readout, motor 2	0.0-20.0A			
▲ C262 ^B	Set motor current readout, motor 2 opening	0.0 and 0.5-6.0A	0.8		25
▲ C263 ^B	Set motor current readout, motor 2 closing	0.0 and 0.5-6.0A	0.8		25
C271 ^{AC}	Power factor readout motor 1	0.00-0.99 cos φ			
C281 ^{BC}	Power factor readout motor 2	0.00-0.99 cos φ			

A = Not shown as L001 = 0; B = Not shown as L002 = 0, C = Not shown as C202 = 4

Photocell

No.	Name	Range	Factory	Set- ting	Ref. page
C340	Safety function in closing movement	0 – 3	1		28
	0	Disabled			
	1	Reverse to fully open			
	2	Stop with automatic restart of automatic closing			
	3	Stop, wait for new control signal or time in C520 and thereafter automatic closing.			
C341	Safety during run-on time or disengagement angle in closing movement.	0 - 1	1		
	0	Disabled when both halves are in run-on or disengagement angle			
	1	Activated according to C340			
C342	Safety function in opening movement	0 – 4	0		28
	0	Disabled			
	1	Reverse to fully closed.			
	2	Stop with automatic restart of automatic closing			
	3	Stop, wait for new control signal or time in C520 and thereafter automatic closing.			
	4	Stop with restart of opening			
C343	Check of external protection connected to PHOTO	0 - 1	1		
	0	No check			
	1	Test of break in continuity for protection connected to PHOTO			
C351	PHOTO closing after time in C510	0 – 1	0		31
	0	Disabled			
	1	Enabled and subordinated to C340			
C354	Type of closing with PHOTO	1 – 2	2		31
	1	Close immediately if PHOTO is clear			
	2	Continues to fully open, then closes if PHOTO is disabled			

General time channels.

No.	Name	Range	Factory	Setting	Ref. page
▲ C436	Stop during run-on time or disengagement angle in closing, subordinated to C448 and C449	0 - 3	3		31
	0	No stop function activated			
	1	Stop with triggered load guard			
	2	Stop with activated safety edge			
	3	Stop with activated safety edge or with triggered load guard			
▲ C448	Reversing during run-on time or disengagement angle with safety edge activated, L117, L127, L213, L223	0 - 2	2		31
	0	No reversing			
	1	Reversing in closing movement			
	2	Reversing in closing and during time in C492, Change of direction delay			
▲ C449	Reversing during run-on time or disengagement angle with load guard triggered, L117, L127, L213, L223	0 - 1	1		31
	0	No reversing			
	1	Reversing in closing movement			
C460	Time delay before second motor starts. Start of motor 2 is delayed during opening Start of motor 1 is delayed during closing	0.1-9.9 seconds	0.1		
C470	Time delay before first motor starts. Start of motor 1 is delayed during opening Start of motor 2 is delayed during closing	0.00-0.99 seconds	0.00		
▲ C492	Reverse delay if PHOTO, SL1 or SL2 or control signal are activated.	0.1-4.0 seconds	0.8		31
▲ C493	Reverse delay if safety edge or load guard are activated	0.03-2.00 seconds	0.10		31
▲ C494	Closing time after activated protection function, safety edge or load guard, while opening	0.1-2.0 seconds	1.0		
C495	Engagement time for brake, motor 1	00, 10-50 ms	00		29
C496	Engagement time for brake, motor 2	00, 10-50 ms	00		

Automatic closing

No.	Name	Range	Factory	Setting	Ref. page
C500	Time before automatic closing 000,0 means disabled function	000.0-600.0 seconds	000.0		30
C510	Time before closing, after passage, on photocell closing and loop closing. Subordinated to C351, d151 and d251.	00-99 seconds	00		30
C520	Blocking time for automatic closing after the stop button is activated 000 means disabled function	000 and 020-600 seconds	000		31
C591	Closing using loops and photocell	00 - 14	00		31
	00	Disabled			
	01	Presence detection, LOOP1 must first be activated, closes when LOOP1 is clear.			
	02	Presence detection, LOOP2 must first be activated, closes when LOOP2 is clear.			
	03	Presence detection, LOOP1 or LOOP2 must first be activated, closes when either LOOP1 or LOOP2 is clear.			
	04	Presence detection, PHOTO must first be activated, closes when PHOTO is clear.			
	05	Presence detection, PHOTO and LOOP1 must first be activated simultaneously, then close when either PHOTO or LOOP1 is clear.			
	06	Presence detection, PHOTO and LOOP2 must first be activated simultaneously, then close when either PHOTO or LOOP2 is clear.			
	07	Presence detection, PHOTO LOOP1 and LOOP2 must first be activated simultaneously, close when either PHOTO, LOOP1 or LOOP2 is clear.			
	08	Presence detection, LOOP1 and LOOP2 must first be activated simultaneously, close when either LOOP1 or LOOP2 is clear.			
	09	Direction sensing, LOOP1 must first be activated, during the time LOOP2 must be activated, then LOOP1 must be clear, closes when LOOP2 is clear.			
	10	Direction sensing, LOOP1 must first be activated, during the time PHOTO must be activated, then LOOP1 must be clear, closes when PHOTO is clear.			
	11	Direction sensing, LOOP2 must first be activated, during the time LOOP1 must be activated, then LOOP2 must be clear, closes when LOOP1 is clear.			
	12	Direction sensing, LOOP2 must first be activated, during the time PHOTO must be activated, then LOOP2 must be clear, closes when PHOTO is clear..			
	13	Direction sensing, PHOTO must first be activated, during the time LOOP1 must be activated, then PHOTO must be disabled,closes when LOOP1 is clear.			
	14	Direction sensing, PHOTO must first be activated, during the time LOOP2 must be activated, then PHOTO must be disabled, closes when LOOP2 is clear.			

Communication

No.	Name	Range	Factory	Setting	Ref. page
C600	Choice of communication	0 – 2	0		
	0	Disabled			
	1	Interlock			
	2	Simply connect			

Interlock

C610	Choice of unit address	1 – 2	2		
C614	Block of local door	0 – 3	0		
	0	No blocking of the local door depending on position of remote door			
	1	Block of open on local door until remote door is closed			
	2	Block of open on local door until remote door is open			
	3	Blocking of close on local door until remote door is closed			
C615	In block of local door	0 – 3	3		
	0	Stopped local door does not disable blocking of remote door Local door does not remember open and stop			
	1	Stopped local door does not disable blocking of remote door Local door remembers open and stop			
	2	Stopped local door disables blocking of remote door Local door does not remember open and stop			
	3	Stopped local door disables blocking of remote door Local door remembers open and stop			

Simply connect

C620	Choice of unit address	1 – 4	1		
C621	Channel access	0 – 1	1		
	0	Reading only			
	1	Reading and writing			
C630	Simply connect pin code	0000 – 9999	0000		

Configuration

No.	Name	Range	Factory	Setting	Ref. page
C700	Selection of application	0 – 7	2		15
	0	Not selected			
	1	Gate, Swing gate			
	2	Gate, Folding gate			
	3	Gate, Sliding gate			
	4	Door, Swing door			
	5	Door, Folding door			
	6	Door, Sliding door			
	7	Barrier			
C701	Magnetic lock control DB310	0 – 1	0		
	0	Not installed, does not affect display of channels			
	1	Installed			
C702	Vehicle detector DB402	0 – 1	0		
	0	Not installed, d-channels not displayed			
	1	Installed			
C705	Encoder card DB405	0 – 1	0		
	0	Not installed, does not affect display of L-channels			
	1	Installed, the settings in L001 and L002 also control display of L-channels			
C707	Output card DB407	0 – 1	0		
	0	Not installed, o-channels not displayed			
	1	Installed			
C709	Frequency converter card DB409	0 – 1	0		
	0	Not installed, does not affect display of F-channels			
	1	Installed, selection in channel C202 also controls display of the F-channels			
C710	Output channel DB410, o-channels not displayed	0 – 1	0		
	0	Not installed			
	1	Installed			
C711	Radio card DB411	0 – 1	0		
	0	Not installed, r-channels not displayed			
	1	Installed			
C712	Adapter card DB512	0 – 1	0		
	0	Not installed, does not affect display of channels			
	1	Installed			

Service channels

No.	Name	Range	Factory	Setting	Ref. page
C900	Service channel, for service personnel only Random number	000 - 999			
C901	Service channel, for service personnel only.	00 - 99	00		
	00	No function selected			
	10	Channel values locked for editing.			
	80	Erasure of error code list in channel C903			
C902	Service channel, for service personnel only, checksum	0000-FFFF			
C903	Error code list showing the most recent error events.				
	_____	Start of the list, followed by the latest message when the minus button is pressed.			
	E003-E976	Error messages, use + and - buttons to step up or down.			
	n021-n074	Message, use + and - buttons to step up or down.			
	_____	End of the list, followed by the oldest message when the plus button is pressed.			
C904	Message on display and in error code list.	0 - 1	1		
	0	Message is neither displayed nor stored in the error code list			
	1	Message is displayed and stored in the error code list			
C999	Display mode	0 - 4	2		15
	0	No restriction on channel display.			
	1	Shows only channels that differ from factory settings, use + and - to step up or down. The button on the far left is used for rapid stepping between the channel groups, has no function in this position.			
	2	Displays only the channels needed for choosing voltage supply, setting of open and closed position and motor protection.			
	3	Displays only the channels needed for setting of load guard, motor protection, gear ratio, limit switch type and selection of application.			
	4	Displays channels for selecting application and add-on boards.			

- Limit switch, L-channels

No.	Name	Range	Factory	Setting	Ref. page
L001	Choice of limit switch type for motor 1	0 - 3	0		22
	0	Motor 1 disabled, no limit switch chosen			
	1	Encoder			
	2	Limit switch			
	3	Time			
	4	Hold-to-run without limit switches. NOTE! Only one half at a time can be run. C033 must be set to 5.			
L002	Choice of limit switch type for motor 2	0 - 3	0		22
	0	Motor 2 disabled, no limit switch chosen			
	1	Encoder			
	2	Limit switch			
	3	Time			
	4	Hold-to-run without limit switches. NOTE! Only one half at a time can be run. C033 must be set to 5.			

Encoder

L110 ¹	Position of motor 1, viewed from the motor side	0 - 2	1		22
	0	No location chosen, L111 shows 000			
	1	Left			
	2	Right			
L111 ¹	Position angle readout motor 1	000-360 degrees			
L112 ¹	Angle for open position, motor 1	145-330 degrees	260		22
L113 ¹	Limit for closed position, motor 1	015-200 degrees	90		22
L116 ¹	Angle for limited opening, motor 1.	0-200 degrees	45		
L117 ¹	Angle for disconnection of safety edge, load guard and photocell from the end of the closing movement, motor 1 in combination with C436, C341 and C448	0-30 degrees	0		
L118 ¹	Angle for the disconnection of vehicle loops from the end of the closing movement, motor 1 in combination with d141 or d241.	0-45 degrees	0		
L120 ²	Position of motor 2, viewed from the motor side	0 - 2	2		22
	0	No location chosen, L121 shows 000			
	1	Left			
	2	Right			
L121 ²	Position angle readout motor 2	000-360 degrees			
L122 ²	Angle for open position, motor 2	145-330 degrees	260		22
L123 ²	Limit for closed position, motor 2	015-200 degrees	90		22
L126 ²	Angle for limited opening, motor 2.	0-200 degrees	45		
L127 ²	Angle for disconnection of safety edge, load guard and photocell from the end of the closing movement, motor 2 in combination with C436, C341 and C448	0-30 degrees	0		
L128 ²	Angle for the disconnection of vehicle loops from the end of the closing movement, motor 2 in combination with d141 or d241.	0-45 degrees	0		

1 = Only displayed if L001 is set to 1 or 4. 2 = Only displayed if L002 is set to 1 or 4.

Limit switch

No.	Name	Range	Factory	Setting	Ref. page
L203 ^A	Setting limited running time (Not used with encoder)	001-999 seconds	001		
L211 ^A	Running time readout, motor 1	000-999 seconds			
L212 ^{AB}	Run-on time following limit switch open, motor 1	0.00-7.99 seconds	0.00		22
L213 ^A	Run-on time following limit switch closed, motor 1	0.00-7.99 seconds	0.00		22
L216 ^A	Set limited opening, motor 1 with limit switch	00.3-99.9 seconds	05.0		
L221 ^A	Running time readout, motor 2	000-999 seconds			
L222 ^{AC}	Run-on time following limit switch open, motor 2	0.00-7.99 seconds	0.00		22
L223 ^A	Run-on time following limit switch closed, motor 2	0.00-7.99 seconds	0.00		22
L226 ^A	Set limited opening, motor 2 with limit switch	00.3-99.9 seconds	05.0		

Time control

L311	Time readout for motor 1	00.1-99.9 seconds			
L312 ^A	Set time for motor 1	00.1-99.9 seconds	00.1		22
L321	Time readout for motor 2	00.1-99.9 seconds			
L322 ^A	Set time for motor 2	00.1-99.9 seconds	00.1		22

A = Only displayed if L001 and/or L002 are set to 2 or 3.

B = Only displayed if L001 = 1 and C202 = 4, frequency converter.

C = Only displayed if L002 = 1 and C202 = 4, frequency converter.

- Programmable inputs, P channels

Programmable input 1

No.	Name	Range	Factory	Setting	Ref. page
P100	Programmable input 1	0 - 1	1		30
	0	Disabled			
	1	Enabled			
P160	Control function	0 - 5	1		30
	0	Disabled			
	1	Open			
	2	Close			
	3	Stop			
	4	Open/close			
	5	Open/stop/close			
▲ P161	Type of control signal when activated	1 - 2	1		30
	1	Pulse (hold-to-run mode not possible)			
	2	Signal for as long as the input is activated			
P162	Half operation	1 - 3	3		30
	1	Motor 1			
	2	Motor 2			
	3	Motors 1 and 2			
P163	Limited opening	0 - 1	0		30
	0	Disabled			
	1	Opening according to set time in channel L216/L226 or number of degrees in L116/L126 if encoder is used.			
P170	Motor lock	0 - 1	0		30
	0	Disabled			
	1	The barrier cannot be operated without a signal at programmable input 1. If the signal disappears ongoing movement stops.			
P175	Opening via input after activation during set time, input will not open the gate until it has been activated for the set time.	0.0-9.9 seconds	0.0		30
P180	Park	0 - 2	2		30
	0	Disabled			
	1	Automatic closing disabled after the input is activated, reset by another control signal			
	2	Automatic closing disabled by a constant signal.			
P190	Interlock opening	0 - 1	0		30
	0	Disabled			
	1	Opens the local door if P160 is set to open, and passes the signal on to the remote door			
P196	Blocking disabled for local and remote doors. Works only with a constant signal.	0 - 1	0		30
	0	Disabled, function according to channel C614			
	1	Blocking disabled			
P198	Automatic closing switched off for remote door. Only works if there is a constant signal	0 - 1	0		30
	0	Disabled, function according to channel C500			
	1	Automatic closing switched off			

Programmable input 2

No.	Name	Range	Factory	Setting	Ref. page
P200	Programmable input 2	0 - 1	1		30
	0	Disabled			
	1	Enabled			
P260	Control function	0-5	2		30
	0	Disabled			
	1	Open			
	2	Close			
	3	Stop			
	4	Open/close			
	5	Open/stop/close			
▲ P261	Type of control signal when activated	1 - 2	1		30
	1	Pulse (hold-to-run mode not possible)			
	2	Signal for as long as the input is activated			
P262	Half operation	1 - 3	3		30
	1	Motor 1			
	2	Motor 2			
	3	Motors 1 and 2			
P263	Limited opening	0 - 1	0		30
	0	Disabled			
	1	Opening according to set time in channel L216/L226 or number of degrees in L116/L126 if encoder is used.			
P270	Motor lock	0 - 1	0		30
	0	Disabled			
	1	The barrier cannot be operated without a signal at programmable input 2. If the signal disappears ongoing movement stops.			
P275	Opening via input after activation during set time, input will not open the gate until it has been activated for the set time.	0.0-9.9 seconds	0.0		30
P280	Park	0 - 2	0		30
	0	Disabled			
	1	Automatic closing disabled after the input is activated, reset by another control signal			
	2	Automatic closing disabled by a constant signal.			
P290	Interlock opening	0 - 1	0		30
	0	Disabled			
	1	Opens the local door if P260 is set to open, and passes the signal on to the remote door			
P296	Blocking disabled for local and remote doors. Works only with a constant signal.	0 - 1	0		30
	0	Disabled, function according to channel C614			
	1	Blocking disabled			
P298	Automatic closing switched off for remote door. Only works if there is a constant signal	0 - 1	0		30
	0	Disabled, function according to channel C500			
	1	Automatic closing switched off			

Programmable input 3

No.	Name	Range	Factory	Setting	Ref. page
P300	Programmable input 3	0 - 1	1		30
	0	Disabled			
	1	Enabled			
P360	Control function	0 - 5	1		30
	0	Disabled			
	1	Open			
	2	Close			
	3	Stop			
	4	Open/close			
	5	Open/stop/close			
▲ P361	Type of control signal when activated	1 - 2	2		30
	1	Pulse (hold-to-run mode not possible)			
	2	Signal for as long as the input is activated			
P362	Half operation	1 - 3	3		30
	1	Motor 1			
	2	Motor 2			
	3	Motors 1 and 2			
P363	Limited opening	0 - 1	0		30
	0	Disabled			
	1	Opening according to set time in channel L216/L226 or number of degrees in L116/L126 if encoder is used.			
P370	Motor lock	0 - 1	0		30
	0	Disabled			
	1	The barrier cannot be operated without a signal at programmable input 3. If the signal disappears ongoing movement stops.			
P375	Opening via input after activation during set time, input will not open the gate until it has been activated for the set time.	0.0-9.9 seconds	0.0		30
P380	Park	0 - 2	0		30
	0	Disabled			
	1	Automatic closing disabled after the input is activated, reset by another control signal			
	2	Automatic closing disabled by a constant signal.			
P390	Interlock opening	0 - 1	0		30
	0	Disabled			
	1	Opens the local door if P360 is set to open, and passes the signal on to the remote door			
P396	Blocking disabled for local and remote doors. Works only with a constant signal.	0 - 1	0		30
	0	Disabled, function according to channel C614			
	1	Blocking disabled			
P398	Automatic closing switched off for remote door. Only works if there is a constant signal	0 - 1	0		30
	0	Disabled, function according to channel C500			
	1	Automatic closing switched off			

Programmable input 4

No.	Name	Range	Factory	Setting	Ref. page
P400	Programmable input 4	0 - 1	1		30
	0	Disabled			
	1	Enabled			
P460	Control function	0 - 5	2		30
	0	Disabled			
	1	Open			
	2	Close			
	3	Stop			
	4	Open/close			
	5	Open/stop/close			
▲ P461	Type of control signal when activated	1 - 2	2		30
	1	Pulse			
	2	Signal for as long as the input is activated			
P462	Half operation	1 - 3	3		30
	1	Motor 1			
	2	Motor 2			
	3	Motors 1 and 2			
P463	Limited opening	0 - 1	0		30
	0	Disabled			
	1	Opening according to set time in channel L216/L226 or number of degrees in L116/L126 if encoder is used.			
P470	Motor lock	0 - 1	0		30
	0	Disabled			
	1	The barrier cannot be operated without a signal at programmable input 4. If the signal disappears ongoing movement stops.			
P475	Opening via input after activation during set time, input will not open the gate until it has been activated for the set time.	0.0-9.9 seconds	0.0		30
P480	Park	0 - 2	0		30
	0	Disabled			
	1	Automatic closing disabled after the input is activated, reset by another control signal			
	2	Automatic closing disabled by a constant signal.			
P490	Interlock opening	0 - 1	0		30
	0	Disabled			
	1	Opens the local door if P460 is set to open, and passes the signal on to the remote door			
P496	Blocking disabled for local and remote doors. Works only with a constant signal.	0 - 1	0		30
	0	Disabled, function according to channel C614			
	1	Blocking disabled			
P498	Automatic closing switched off for remote door. Only works if there is a constant signal	0 - 1	0		30
	0	Disabled, function according to channel C500			
	1	Automatic closing switched off			

Programmable input 5

No.	Name	Range	Factory	Setting	Ref. page
P500	Programmable input 6	0 - 1	1		16
	0	Disabled			
	1	Activated (Only channels P560-P598 activated)			
	2	Battery operation, only together with frequency inverter (Channels P560-P598 disabled)			
P560	Control function	0 - 5	0		30
	0	Disabled			
	1	Open			
	2	Close			
	3	Stop			
	4	Open/close			
	5	Open/stop/close			
▲ P561	Type of control signal when activated	1 - 2	1		30
	1	Pulse			
	2	Signal for as long as the input is activated			
P562	Half operation	1 - 3	3		30
	1	Motor 1			
	2	Motor 2			
	3	Motors 1 and 2			
P563	Limited opening	0 - 1	0		30
	0	Disabled			
	1	Opening according to set time in channel L216/L226 or number of degrees in L116/L126 if encoder is used.			
P570	Motor lock	0 - 1	0		30
	0	Disabled			
	1	The barrier cannot be operated without a signal at programmable input 5. If the signal disappears ongoing movement stops.			
P575	Opening via input after activation during set time, input will not open the gate until it has been activated for the set time.	0.0-9.9 seconds	0.0		30
P580	Park	0 - 2	0		30
	0	Disabled			
	1	Automatic closing disabled after the input is activated, reset by another control signal			
	2	Automatic closing disabled by a constant signal.			
P590	Interlock opening	0 - 1	0		30
	0	Disabled			
	1	Opens the local door if P560 is set to open, and passes the signal on to the remote door			
P596	Blocking disabled for local and remote doors. Works only with a constant signal.	0 - 1	0		30
	0	Disabled, function according to channel C614			
	1	Blocking disabled			
P598	Automatic closing switched off for remote door. Only works if there is a constant signal	0 - 1	0		30
	0	Disabled, function according to channel C500			
	1	Automatic closing switched off			

Programmable input 6

No.	Name	Range	Factory	Setting	Ref. page
P600	Programmable input 6	0 - 1	1		30
	0	Disabled			
	1	Activated (Only channels P660-P698 activated)			
	2	Safety input (Only channels P640-P643 activated)			
P640	Safety function when input is activated	0 - 3	1		28
	0	Disabled			
	1	Reverse to fully open			
	2	Stop with automatic restart of automatic closing			
	3	Stop, wait for new control signal or time in C520 and thereafter automatic closing.			
P641	Safety during run-on time or disengagement angle in closing movement.	0 - 1	0		28
	0	Disabled when both halves are in run-on or disengagement angle			
	1	Activated according to P640			
P642	Protection in opening movement	0 - 4	1		28
	0	Disabled			
	1	Reverse to fully closed			
	2	Stop with automatic restart of automatic closing			
	3	Stop, wait for new control signal or time in C520 and then automatic closing.			
	4	Stop with restart of opening			
P643	Control of external protection connected to INP6	0 - 1	1		28
	0	No check			
	1	Test of break in continuity for protection connected to INP6			
P660	Control function	0 - 5	0		30
	0	Disabled			
	1	Open			
	2	Close			
	3	Stop			
	4	Open/close			
	5	Open/stop/close			
▲ P661	Type of control signal when activated	1 - 2	1		30
	1	Pulse			
	2	Signal for as long as the input is activated			
P662	Half operation	1 - 3	3		30
	1	Motor 1			
	2	Motor 2			
	3	Motors 1 and 2			
P663	Limited opening	0 - 1	0		30
	0	Disabled			
	1	Opening according to set time in channel L216/L226 or number of degrees in L116/L126 if encoder is used.			

No.	Name	Range	Factory	Setting	Ref. page
P670	Motor lock	0 - 1	0		30
	0	Disabled			
	1	The barrier cannot be operated without a signal at programmable input 6. If the signal disappears ongoing movement stops.			
P675	Opening via input after activation during set time, input will not open the gate until it has been activated for the set time.	0.0-9.9 seconds	0.0		30
P680	Park	0 - 2	0		30
	0	Disabled			
	1	Automatic closing disabled after the input is activated, reset by another control signal			
	2	Automatic closing disabled by a constant signal.			
P690	Interlock opening	0 - 1	0		30
	0	Disabled			
	1	Opens the local door if P660 is set to open, and passes the signal on to the remote door			
P696	Blocking disabled for local and remote doors. Works only with a constant signal.	0 - 1	0		30
	0	Disabled, function according to channel C614			
	1	Blocking disabled			
P698	Automatic closing switched off for remote door. Only works if there is a constant signal	0 - 1	0		30
	0	Disabled, function according to channel C500			
	1	Automatic closing switched off			

Error messages in display and in the error code list in channel C903

Grey background means that the automatic control unit must be restarted (power off) in order to reset the error message.

Error code	Meaning	Possible cause
EP-1	Not an error code – indicates the type of EP105 in use	
EP-2	Not an error code – indicates the type of EP105 in use	
E000	No error, shown to acknowledge a change in the service channel.	
E003	Limited running time exceeded	Gears slipping? Check the time in L203
E008	Momentary loss of 24 V	Mains failure, momentary 24 V short circuit.
E015	Loss of mains power 230 V	Has there been a power failure?
E016	Momentary loss of 230V	Has there been a power failure?
E017	Safety edge or load guard triggered five times in succession	Is something preventing the door reaching the closed position?
E020	Voltage too high in safety circuit	The voltage measured by the automatic control unit is too high.
E021	Voltage too low in safety circuit	Poor contact through connected buttons?
E025	Incorrect setting for personal protection, motor 1	Check C200 and C230, the load guard cannot be disabled, C200=0 with personal protection activated, value in C230. Check C211, it must not be longer than 0.06 seconds. C212 cannot be longer than 2 seconds. C493 cannot be longer than 0.20 seconds.
E026	Incorrect setting for personal protection, motor 2	Check C200 and C240, the load guard must not be disabled, C200=0 with personal protection activated, value in C240. Check C211, it must not be longer than 0.06 seconds. C212 cannot be longer than 2 seconds. C493 cannot be longer than 0.20 seconds.
E028	Brake selected when C202 is set to 2, 4 or 5	Check that C495/C496 is set to 0.
E032	Limit switch L.O1 has lost its position	Is the limit switch cam bypassing the switch? Loose connection in switch?
E033	Limit switch L.C1 has lost its position	Is the limit switch cam bypassing the switch? Loose connection in switch?
E034	Limit switch L.O2 has lost its position	Is the limit switch cam bypassing the switch? Loose connection in switch?
E035	Limit switch L.C2 has lost its position	Is the limit switch cam bypassing the switch? Loose connection in switch?
E044	Hidden channels shown	No error, information only
E046	Opening counter reset	No error, information only
E047	Factory reset of all channels	No error, information only
E048	Error code list reset	No error, information only
E053	Unknown circuit board revision	Contact FAAC Nordic AB
E116	No safety edge acknowledgement	Only applies to up-and-over control, fault in safety edge? Correct run-on time?
E141	SE.O2 is disabled when C104 is set to 3	Indication function of SE.O2 in channel C141
E201	Motor protection triggered for motor 1	Motor is taking more than 1.5x motor current. Motor is sluggish or stops. Faulty fuse? Phase failure in an incoming phase? Break in cable to motor or motor winding? Check the motor protection setting in channels C252, C253, C262, C263.
E202	Motor protection triggered for motor 2	
E203	Motor protection triggered four times in a row, control unit locked for 3 minutes	Is there an obstacle? Fault in electric motor? Check the configuration of channels C252, C253, C262, C263.

Error code	Meaning	Possible cause
E204	Current through motor 1, which is switched off	Contact FAAC Nordic AB.
E205	Current through motor 2, which is switched off	Contact FAAC Nordic AB.
E206	No current or low current in motor 1	The electric motor is running at less than half the motor protection setting. Check the motor protection setting. Phase failure in an incoming phase? Faulty fuse? Break in cable to electric motor? Voltage drop in stop circuit/limit switch circuit? Check the settings of the motor protection in C252, C253, C262 and C263 against C251 and C261.
E207	No current or low current in motor 2	
E221	Start load too low, motor 1	Check that the motor is correctly connected and that the value in C230 agrees with C231.
E222	Start load too low, motor 2	Check that the motor is correctly connected and that the value in C240 agrees with C241.
E223	Normal power too low, motor 1	Check that the value in C230 agrees with C231.
E224	Normal power too low, motor 2	Check that the value in C240 agrees with C241.
E225	The load guard has been tripped three times in a row	Obstacle in the way? Mechanical fault preventing closing? Check the settings of the load guard in C230, C232, C233, C240, C242 and C243 against C231 and C241.
E318	Error in vehicle loop 1	Are the loop and connectors electrically continuous?
E319	Error in vehicle loop 2	For more troubleshooting tips, see the instruction manual for the vehicle detector
E614	Interlock communication error	Correct polarity in communication cables? Break in communication cable? Correct settings in both automatic control units? Is the external unit switched on?
E651	No response from frequency converter motor 1	Check the connection and the settings as described in Instruction Manual for DB409. Address must be set for the frequency converter.
E652	No response from frequency inverter motor 2	Check the connection and the settings as described in Instruction Manual for DB409. Address must be set for the frequency converter.
E661	Incorrect value sent to frequency converter motor 1	Check the settings in the frequency inverter against the instruction manual for DB409
E662	Incorrect value sent to frequency inverter motor 2	Check the settings in the frequency inverter against the instruction manual for DB409
E671	Incorrect response from frequency converter motor 1	Check the settings in the frequency inverter against the instruction manual for DB409
E672	Incorrect response from frequency inverter motor 2	Check the settings in the frequency inverter against the instruction manual for DB409
E901	Extraneous voltage at safety edge input SE.C1	Disconnect the terminals marked 1-11 and 2-12. Do a restart using the main on/off switch. Contact FAAC Nordic AB if the fault persists, otherwise check the safety edges.
E902	Extraneous voltage at safety edge input SE.C2	
E903	Extraneous voltage at safety edge input SE.O1	
E904	Extraneous voltage at limit switch input	Check the connections.
E905	Extraneous voltage in stop circuit	Check the connections.
E906	Extraneous voltage at safety edge input SE.O2	Disconnect the terminals marked 1-11 and 2-12. Do a restart using the main on/off switch. Contact FAAC Nordic AB if the fault persists, otherwise check the safety edges.
E906	Extraneous voltage on limit switch L.O1	Check connections.
E908	Extraneous voltage on limit switch L.O2	Check connections.
E912	Incorrect checksum in flash memory	Contact FAAC Nordic AB.
E913	Memory error in RAM	Contact FAAC Nordic AB.
E914	Memory error in EEPROM	Contact FAAC Nordic AB.
E915	Incorrect EEPROM version	Contact FAAC Nordic AB.

Error code	Meaning	Possible cause
E916	Internal test not completed in time	Contact FAAC Nordic AB.
E917	Incorrect order of execution	Contact FAAC Nordic AB.
E921	Contactor for motor 1 activated before the previously activated contactor has been deactivated.	Contact FAAC Nordic AB.
E922	Contactor for motor 2 activated before the previously activated contactor has been deactivated.	Contact FAAC Nordic AB.
E931	Stop at the same time as an open/close operation.	Use the pulse function for programmable inputs
E932	Open operation at the same time as a close operation.	Use the pulse function for programmable inputs
E941	Motor 1 running in the wrong direction according to the encoder setting.	Check that channel L110 is set to the correct side. Check the motor is running in the right direction.
E942	Motor 2 running in the wrong direction according to the encoder setting.	Check that channel L120 is set to the correct side. Check the motor is running in the right direction.
E943	No movement encoder 1	Check connection to the encoder.
E944	No movement encoder 2	Check connection to the encoder.
E961	SE.C1 did not change to low during the external test.	Check that the safety edge is functional, if the safety edge is not functional, set channel C113 to 0.
E962	SE.C2 did not change to low during the external test.	Check that the safety edge is functional, if the safety edge is not functional, set channel C123 to 0.
E963	SE.O1 did not change to low during the external test.	Check that the safety edge is functional, if the safety edge is not functional, set channel C133 to 0.
E964	PHOTO did not change to low during the external test.	Check that the safety edge is functional, if the safety edge is not functional, set channel C343 to 0.
E965	INP6 did not change to low during the external test.	Check that INP6 is working, if no self-test in the photocell, set channel P643 to 0.
E966	SE.O2 did not change to low during the external test.	Check that the safety edge is functional, if the safety edge is not functional, set channel C143 to 0.
E971	SE.C1 did not change to high during the external test.	Check that the safety edge is functional, if the safety edge is not functional, set channel C113 to 0.
E972	SE.C2 did not change to high during the external test.	Check that the safety edge is functional, if the safety edge is not functional, set channel C123 to 0.
E973	SE.O1 did not change to high during the external test.	Check that the safety edge is functional, if the safety edge is not functional, set channel C133 to 0.
E976	SE.O2 did not change to high during the external test.	Check that the safety edge is functional, if the safety edge is not functional, set channel C143 to 0.

Messages in display and in the error code list in channel C903

Code	Meaning
n021	Safety function for the photocell activated while opening
n022	Safety function for the photocell activated while closing
n031	Safety function for vehicle loop 1 activated while opening
n032	Safety function for vehicle loop 1 activated while closing
n033	Safety function for vehicle loop 2 activated while opening
n034	Safety function for vehicle loop 2 activated while closing
n041	Safety function for safety edge SE .O1 activated while opening
n042	Safety function for safety edge SE .C1 activated while closing
n043	Safety function for safety edge SE .O2 activated while opening
n044	Safety function for safety edge SE .C2 activated while closing
n071	Reverse due to load guard for motor 1 while opening
n072	Reverse due to load guard for motor 1 while closing
n073	Reverse due to load guard for motor 2 while opening
n074	Reverse due to load guard for motor 2 while closing

Troubleshooting

At each service, please check all the functions described in the relevant section on commissioning.

Problem	Possible cause, tip
Error message in the display (Ennn)	See the section above on error messages.
The door reverses and the red LEDs M1/M2 start flashing.	Is the load guard correctly installed? Has the correct supply voltage been set? Mechanical fault? Does the door move easily when decoupled?
Are the red LEDs SE.C1, SE.C2, SE.O1 or SE.O2 on or flashing?	Check the channels for the safety edge value. Is the impedance correct? Adjust the safety edge switch if necessary? Are all the safety edge units in use? Are any of the limit switch LEDs on? The safety edge will not work unless the limit switches are connected at the time the power is switched on. Is the stop LED on? The safety edge will not work unless the stop circuit is uninterrupted at the time the power is switched on.
The door will not open or close.	Are all the green LEDs that should be lit on? Have unused stop inputs been jumpered? Are any of the LEDs INP1-INP6 on? They should not usually be on (unless the system is parked at certain times). The limit switch LEDs must light up before the door can be operated. Example: L.O1 is on = motor 1 can start. The limit switches are connected in series with the stop circuit. Fault/interruption in the wicket door contact or other contact in the stop circuit. Check that the warning is configured. Check that the block is configured.
The door will not close but it will open.	The PHOTO LED should be on. Are any safety edge indications on? They should normally be off. Suspect an incorrect connection to the safety edge. Alternatively, an adjustment may be necessary. Check the channel for pulse operation.
No automatic closing.	Suspect an interruption somewhere in the stop circuit. Wicket door contact? Stop button? Check the setting for restart after stopping.
The display and LEDs do not switch on	Are all supply phases present? Possibly a short circuit to earth in a low current connection. Switch off at the main switch for 1 minute and remove all jackable terminals. Switch on the power again with the jackable terminals disconnected.

You will need to hold down the run button to operate.	Check that the automatic control unit is in pulse mode. Is the PHOTO LED on? Are any of the safety edge LEDs on? Is LOOP1 or LOOP2 lit? These should only be on if a vehicle is over the loop.
Does the door inexplicably close "by itself"? (without an error message or alarm LEDs)	Try to operate the door again, opening and closing. Also check C020 for the most recent stop cause. Cross-check the number with the channel reference to find out what stopped the door.

- **Resetting/replacing tripped fuses**

If the fuse protecting the power supply to the automatic control unit trips, FAAC Nordic AB recommends following these steps to reset/replace it.

- Switch off the main switch to the automatic control unit.
- Decouple the drive unit.
- Reset or replace the fuse.
- Switch on the main switch to the automatic control unit.
- Check that none of the drive units start before receiving the control signal.
- Check that the drive units can be started and stopped from the control buttons.
- If the drive unit cannot be stopped, contact FAAC Nordic AB.



FAAC