

CHANNEL LIST

DAAB AUTOMATIC CONTROL UNIT EP105

Installer's guide for EP105

For full instructions refer to the EP105
Instruction Manual and other documentation supplied





FAAC Nordic AB

BOX 125, SE-284 22 PERSTORP SWEDEN, ☎ +46 435 77 95 00, ✉ support@faac.se

www.faac.se

Safety

CAUTION: Important safety instructions. Following these instructions is important for personal safety. Retain these instructions.

 Carefully read through this instruction manual in its entirety – it contains important information about safety, installation, commissioning and use. Particularly important safety information is identified with the symbol  in the left margin.

If you fail to follow the safety instructions in this instruction manual, there is a risk of serious damage to property or injury to animals or people. You should keep this instruction manual in a safe place for future use.

The EP105 or a unit controlled by the EP105 can be used by children from the age of 8 years and by people with physical, sensory or mental disabilities or inadequate experience and knowledge if supervised, or if they are given instructions on how to use the EP105 or a unit controlled by the EP105 and understand the dangers that may arise.

Children must not play with the installation or the controlled units. Cleaning and maintenance must not be carried out by children.

The EP105 control unit or the accessories recommended by FAAC Nordic AB must not be modified without the explicit consent of FAAC Nordic AB.

Only qualified persons working in their own fields may perform installation, adjustment, commissioning, repair and other work.

Electrical connections may only be made by qualified electricians, who accept responsibility for the connections.

Follow the safety instructions of the equipment to be controlled by the control unit.

• Safety classification

FAAC Nordic AB has validated the safety circuits in the EP105 to performance level PL = c and Category 2 as defined in SS-EN ISO 13849-2:2008.

The EP105 is designed with safety edge inputs and an integrated load guard for use in personal safety applications. These features are designed to meet the requirements of the Machinery Directive 2006/42/EC.

The validation process assumed a technical service life of 10 years or 1 million operating cycles for components in safety circuits.

FAAC Nordic is unable to guarantee this validation when the motor contactors and safety edges exceed this technical service life. For this reason, these components should be replaced before the end of their service life.

Operation

• General

 Anyone installing or modifying the EP105 must have documented knowledge and understanding of its functions, as well as experience of setting up the control system for the application in which it will be used.

Take care when operating internal buttons to avoid touching live components.

The unit may only be connected by a qualified electrician, who accepts responsibility for ensuring that the electric connections have been carried out in accordance with the applicable standards and this instruction manual.

Anyone commissioning the EP105 must have documented knowledge and understanding of its functions, as well as experience of commissioning control systems for the application in which it is used.

• Service and maintenance

 Regular inspection is required of the external safety features of the EP105, such as safety edges, stop buttons, photocells, load guards and safety loops. The condition of the enclosure, cables and installation must also be checked. This inspection must be carried out at least twice a year.

CAUTION: The EP105 must be disconnected from its power supply during cleaning, maintenance and when replacing parts or carrying out repairs.

• Resetting/replacing tripped fuses

If the fuse protecting the power supply to the automatic control unit trips, FAAC Nordic AB recommends following these steps to reset/replace it.

- Switch off the main switch to the automatic control unit.
- Decouple the motor unit.
- Reset or replace the fuse.
- Switch on the main switch to the automatic control unit.
- Check that none of the drive units start before receiving the control signal.
- Check that the drive units can be started and stopped from the control buttons.
- If the drive unit cannot be stopped, contact FAAC Nordic AB.

Connection

CAUTION: Important safety instructions. Follow all instructions, as incorrect installation can cause serious injury.

- Safety

 The electrical connections may only be made by a qualified electrician, who accepts responsibility for ensuring that the electric connections have been carried out in accordance with the applicable standards and this instruction manual.

Always disconnect the power supply when connecting the control box. Mechanical installation of the control unit must be carried out by persons with the necessary knowledge for the task.

- Installation

The location of the control unit must be selected with regard to the protection class of the enclosure, at least IP54. A heating and/or cooling element should be included if necessary to maintain the operating temperature stated in the technical specification.

The control unit must be securely fixed to a wall or a bracket intended for this purpose, using screw joints. The fixing holes are on the rear or underside of the enclosure.

Cables into and out of the enclosure must have cable entry seals that are approved for use with the particular cable. Cables outside the enclosure must be securely fixed to the surrounding structure. They must not hang loose and there must be no possibility of them catching on passing objects.

- High current

The power supply must be connected via a lockable main switch, and have T10A protection. Connect the incoming earth to the earth bar.

Check that the power supply and motor voltage are compatible.

- Motors

The largest motor that can be connected is 1.5 kW (3-phase 3x400 V).

See "Commissioning" for details of how to check the direction of rotation.

Connecting motors to EP105

Supply 3x400V with neutral

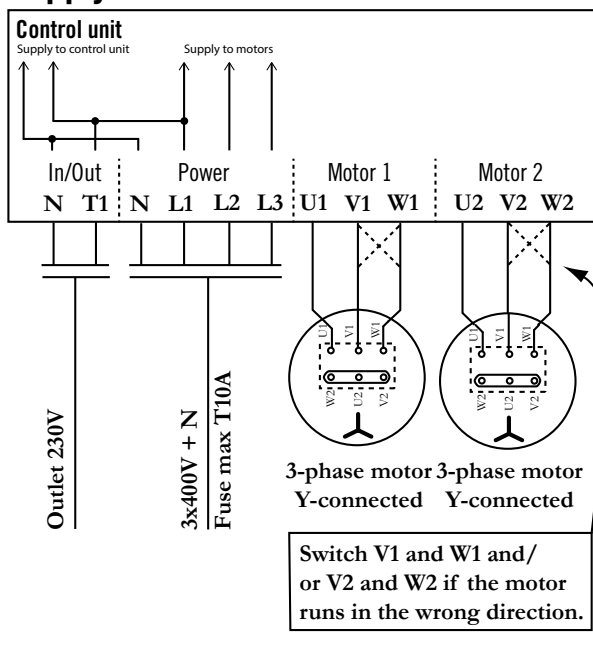

Supply 3x230V without neutral

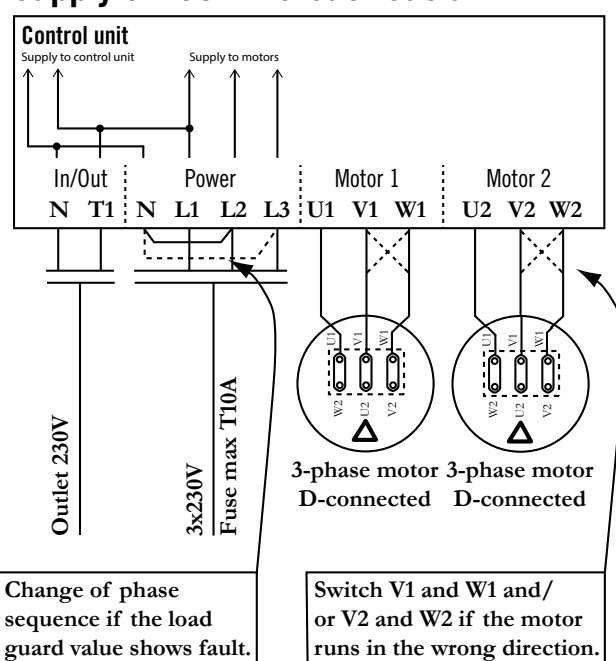

For information about connecting to a frequency converter, see the instructions for add-in card DB409.

Supply 1x230V with neutral (symmetrical)

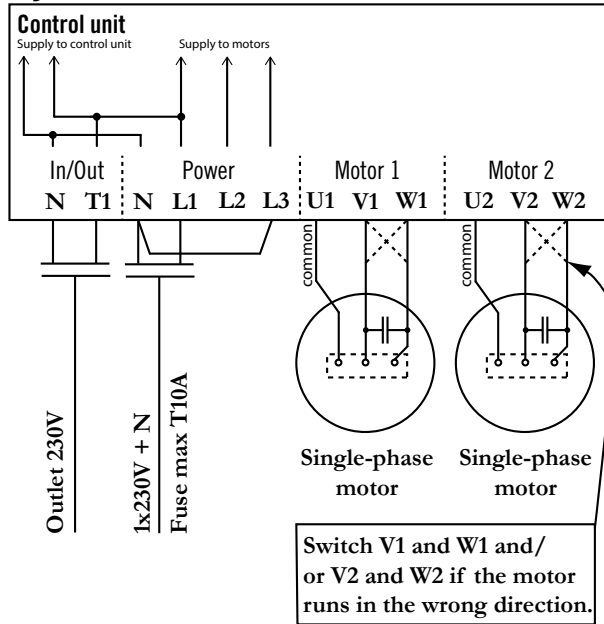

If a symmetrical single-phase motor is used (as shown on the left) make the following changes.

EP105-1: Swap the cable at X12: L1-1 with X12: L1-C1.

EP105-2: Remove the cable between X11: L2-1 and X4: L2-2.

Swap the cable at X12: L1-1 with X12: L1-C1. Swap the cable at X7: L1-2 with X7:L1-C2. See the diagram below for the terminal locations.

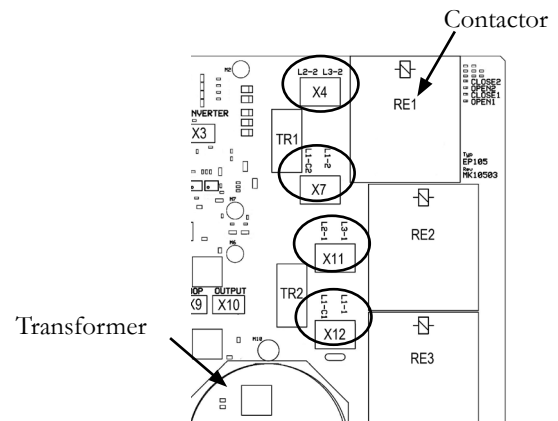

Supply 1x230V with neutral (asymmetrical)

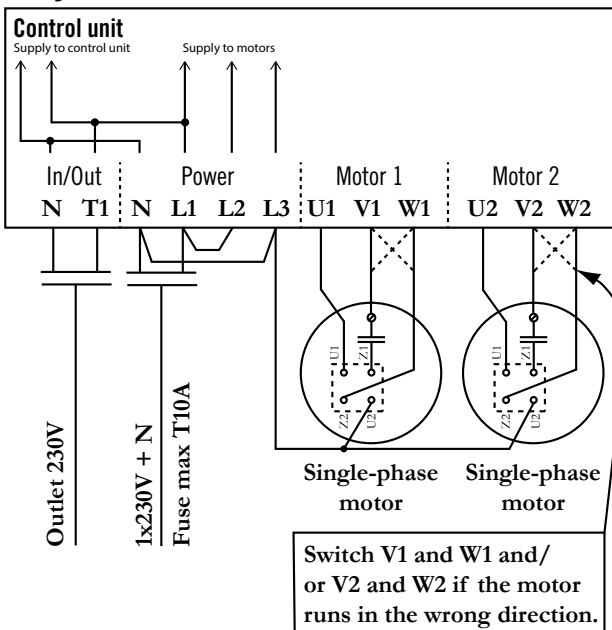

• Connecting a safety edge

The safety edge resistor must be installed in the safety edge so that an open-circuit in the resistor or the cable is interpreted as actuation of the device. See the wiring diagram below. SE.C1 and SE.O1 must be used for a safety edge connected to the half to which motor 1 is connected, and SE.C2 and SE.O2 to the half to which motor 2 is connected.

The impedance can be between 1.0-9.9 kΩ with a 1% tolerance and a power capability of at least 0.5 W. FAAC Nordic AB recommends an impedance of 8.2 kΩ. A safety edge can only be connected in series.

When connecting in series, only one resistor is used in the outermost safety edge, as shown in the wiring diagram below. The maximum number of safety edges connected in series with an impedance of 8.2 kΩ is six per input.

Note that the impedance used for a safety edge must be checked and entered into the EP105 on commissioning, see Commissioning below.

 Other types of impedance safety edge must not be connected directly to the safety edge inputs – they require an external control unit.

See the instruction manual for these safety edges.

Use only safety edges approved by FAAC Nordic AB.

• Connecting safety edges and photocells

The diagram below illustrates how to connect an external safety edge unit.

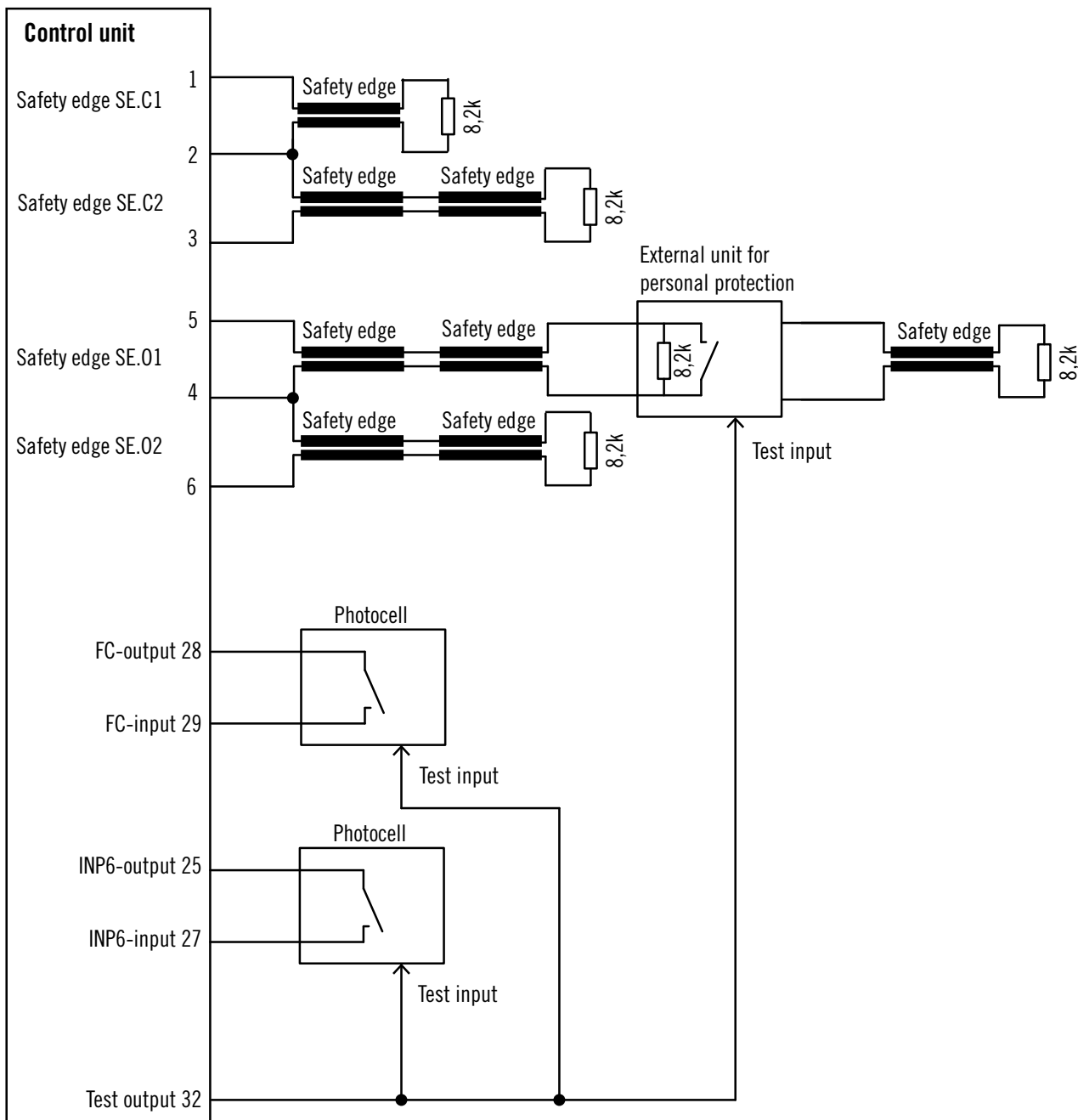

• **Connecting an encoder (electronic limit switch)**

The EP105 supports DB405 type encoders. The encoder uses the same terminals as a conventional mechanical limit switch. The two diagrams below illustrate how to connect the encoder, and they also show which is the left and right motor from the point of view of the automatic control unit. Make sure the cable to the encoder does not share the same buried pipe as the motor power supply.

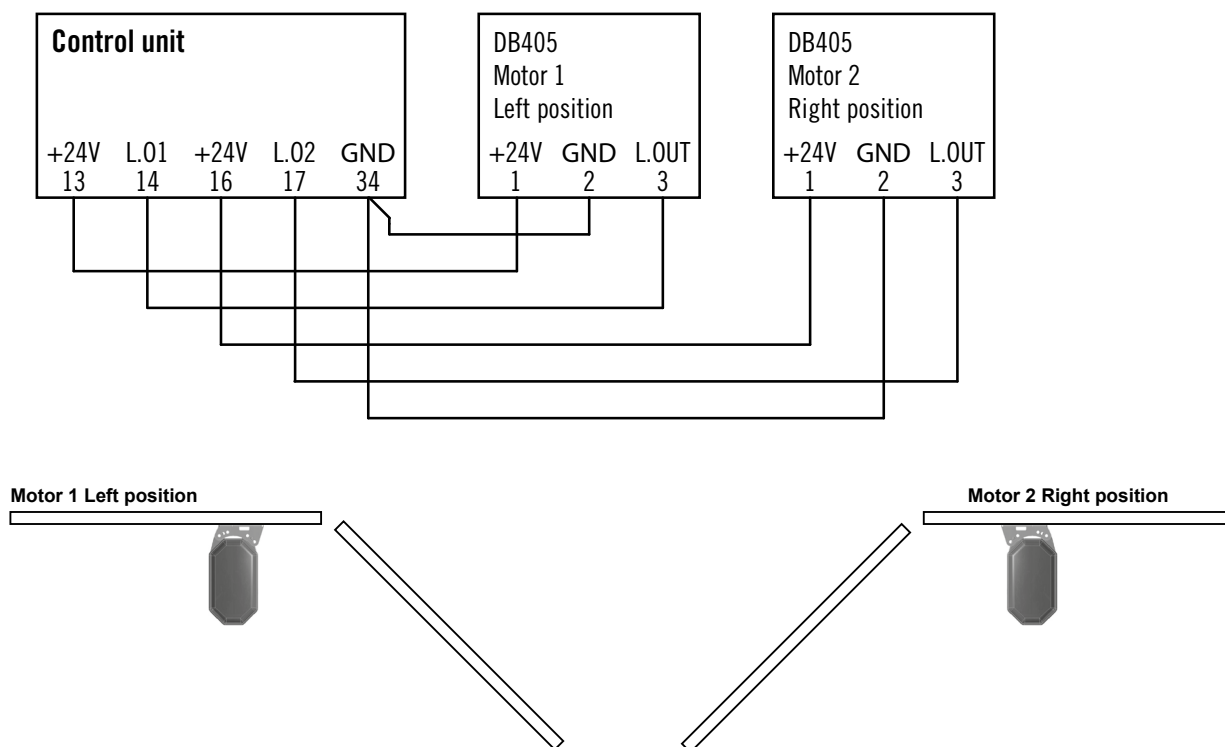

• **Connecting a mechanical limit switch (microswitch)**

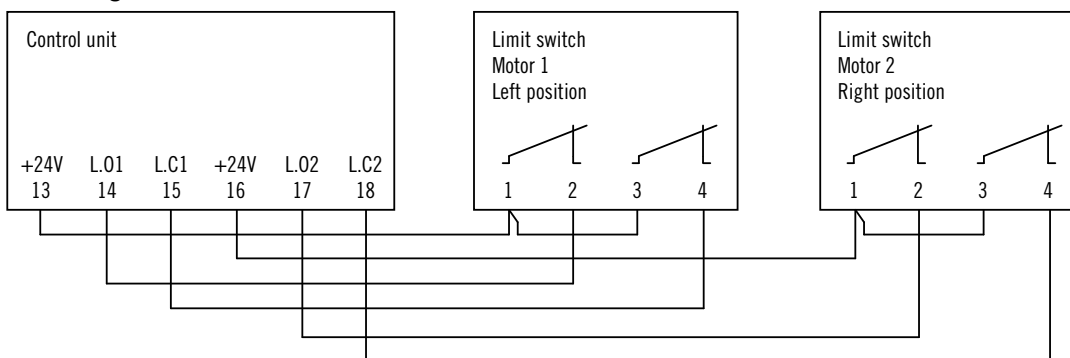

• **Connecting timer control limit switches**

Limit switches can still be used with timer control – they are connected as shown above (mechanical limit switch) but only for the open position. If there is no limit switch, make the connections as shown below. A mechanical stop in the open position must be fitted.

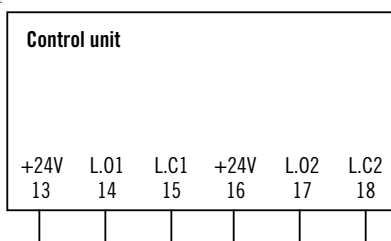

• Signal reference

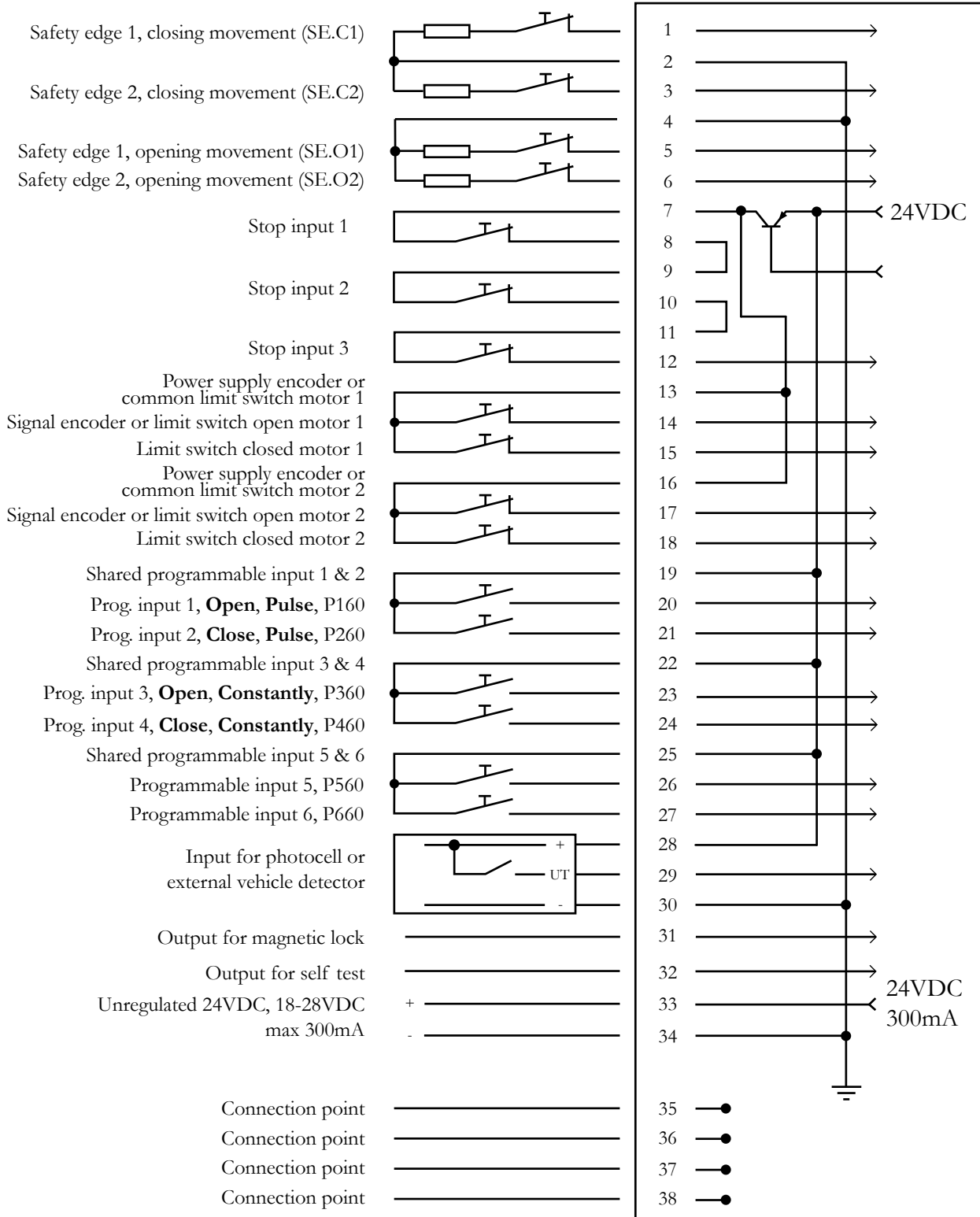

• Low current

The safety circuit, safety edge or limit switch must not be connected to, or used for, any other function. If signals from the EP105 are needed, a separate output card must be used.

The connection instructions are the same for all types of application, but not all signals may be needed.

If stop signals are unused, the associated input signals must be jumpered on the terminal block, see "Signal reference".

Note that the 24 V for the stop circuit must not be combined with other 24 V circuits.

Technical specification

Dimensions (WxHxD)	190x224x60 mm.
Power supply	3-phase or single-phase.
Power supply	3x400 V+N+PE, 3x230 V+PE, 1x230 V+N+PE, 3x400 V+PE (requires an external transformer)
Permitted voltage variation	±10%
Frequency	50 Hz.
Motor in 3-phase operation 3x400 V	3-phase asynchronous motor 0.18-1.5 kW.
Motor in 3-phase operation 3x230 V	3-phase asynchronous motor 0.18-0.75 kW.
Motor in single-phase operation	Single-phase motor with capacitor 0.18-0.37 kW.
Fuses	External fuse max. T10A.
Power consumption	Automatic control unit 22 VA + electric motors.
Operating mode	Intermittent operation 50% / maximum period of operation 2 minutes
Temperature range	0 to 45 °C.
Safety edge	2 closing inputs SE.C1 and SE.C2 for a safety edge while closing. 2 opening inputs SE.O1 and SE.O2 for a safety edge while opening. Variable impedance 1.0-9.9 kΩ, power capability at least 0.5 W.
Safety circuit	Maximum resistance 3 Ω total in the whole safety circuit. Cable length at 0.75 mm ² max 60 m. Cable length at 1.5 mm ² max 120 m.
Internal motor protection	Setting range 0.5-6 A.
Load guard	Setting range 0.05-1.99 kW.
Programmable inputs	6x Low level 0-8 VDC, high level 12-30 VDC. Input current 6 mA at 24 VDC. Cable length maximum 200 metres at cable cross-sectional area 0.75 mm ² (Ø 1 mm)
Limit switch/Encoder	2+2 inputs Input current 2 mA at encoder and 22 mA at limit switch Cable length mechanical limit switches maximum 200 metres at cable cross-sectional area 0.75 mm ² (Ø 1 mm) Cable length DB405 maximum 50 metres at cross-sectional area 0.75 mm ² (Ø 1 mm)
Photocell	1 input Low level 0-8 VDC, high level 12-30 VDC Input current 6 mA at 24 VDC. Cable length maximum 200 metres at cable cross-sectional area 0.75 mm ² (Ø 1 mm) Supply voltage 24 VDC max 50 mA.
External supply	Unregulated 24 VDC, 18-28 VDC, max 300mA
Degree of protection	The PCB is designed for an enclosure rating of at least IP54.

Quick guide for commissioning of gate

• Conditions

Electrical installation has been carried out and drive units are disconnected. Commission one drive unit at a time only and start with drive unit 1. The supply voltage in C202 is set to 0, 3x400V with neutral. The limit switch is of the encoder type. The display channel C999 is set to 2. The indicators for safety edge are unlit. The indicators for photocell, stop circuit and 24V are lit green

• Commissioning of drive unit 1

Direction of movement: Start L001 to 4, hold-to-run without limits. Check that the motor arm attachment is running in the right direction by pressing the OPEN or CLOSE buttons on the automatic control unit. For change of direction of rotation, see section on Connection in EP105 Instruction Manual.

Open and closed position: Connect the gate half to drive unit 1 and enter the positions for open and closed. After this, L001 is set to 1, encoder.

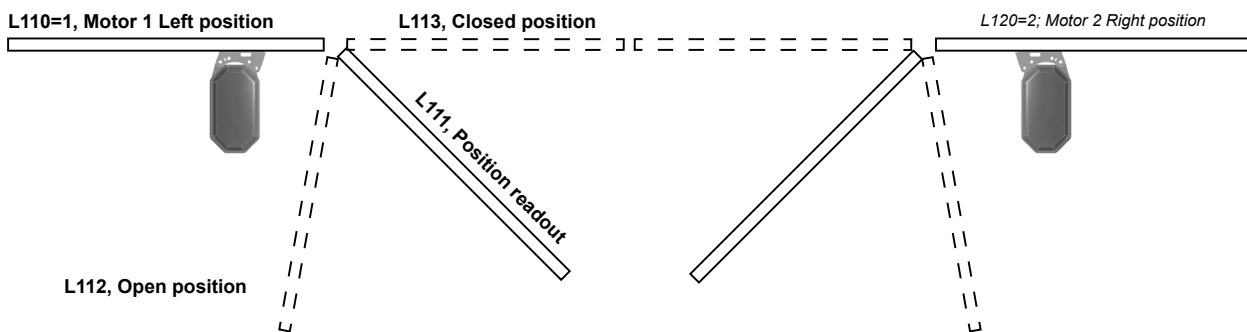

Motor protection: Read the motor current during operation in C251 and enter this value in C252 for opening and in C253 for closing. E201 means that the entered value is set too low. E206 means that the entered value is set too high.

Load guard: Set C999 to 3. In a swing gate application personal protection is not normally required, and C230 is set to 0.00. Set C033 to 3, pulse to activate the load guard. After the load guard has tripped, the indication M1 flashes and the message n071 or n072 is shown on the display and in the error code list in C903. Check that the setting in the load guard in C232 and C233 is at just the right height not to cause material damage, but at the same time is sufficiently high to be guaranteed to open depending on weather conditions and mechanical changes.

Safety edges: Check the safety edges on gate half 1 by activating the safety edges during movement. Note that safety edge function in opening is closed in C131. In activated safety edge during closing, the gate must reverse to the fully open position, while in opening it must reverse to the closed position during the time in C494. Flashing indication for SE.C1 or SE.O1 means that the safety edge has been activated, but is now disabled.

- Commissioning of drive unit 2

Preparations: C999 is set to 2. Open half 1 and set L001 to 0 to keep drive unit 1 in open position. Set C033 to 5, service position.

Direction of movement: Start L002 to 4, hold-to-run without limits. Check that the motor arm attachment is running in the right direction by pressing the OPEN or CLOSE buttons on the automatic control unit. For change of direction of rotation, see section on Connection in EP105 Instruction Manual.

Open and closed position: Connect the gate half to drive unit 2 and enter the positions for open and closed. After this, L002 is set to 1, encoder.

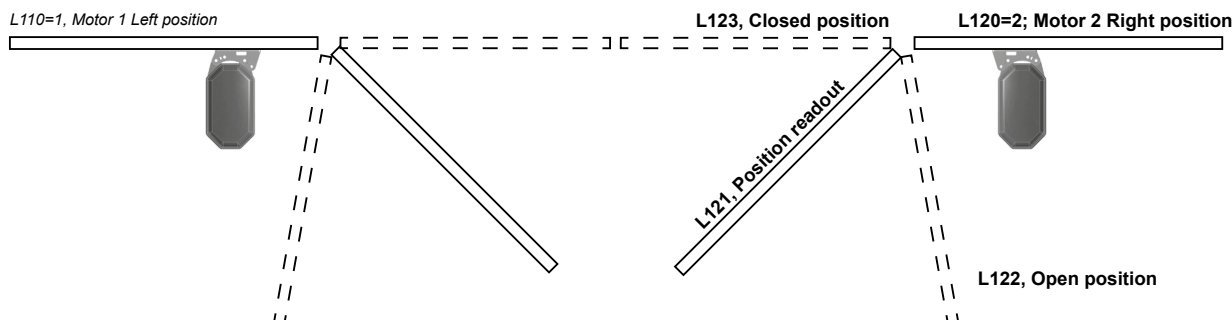

Motor protection: Read the motor current during operation in C261 and enter this value in C262 for opening and in C263 for closing. E202 means that the entered value is set too low. E207 means that the entered value is set too high.

Load guard: C999 is set to 3. In a hinged gate application personal protection is not normally required, and C240 is set to 0.00. Set C033 to 3, pulse to activate the load guard. After the load guard has tripped, the indication M2 flashes and the message n073 or n074 is shown on the display and in the error code list in C903. Check that the setting in the load guard in C242 and C243 is at just the right height not to cause material damage, but at the same time is sufficiently high to be guaranteed to open depending on weather conditions and mechanical changes.

Safety edges: Check the safety edges on gate half 2 by activating the safety edges while moving. Note that safety edge function in opening is closed in C141. In activated safety edge during closing, the gate must reverse to the fully open position, while in opening it must reverse to closed position during the time in C494. Flashing indication for SE.C2 or SE.O2 means that the safety edge has been activated, but is now disabled.

Additional boards: Set C999 to 4. Channels C702 to C712 show or hide channels for additional boards. If e.g. DB407, Output board, to be used set C707 to 1

Finishing: Set C999 to 0, display of all channels. Set L001 to 1, encoder and make fine adjustments to the gate halves in closed position using L113 and L123. Note all changed channels in EP105 Instruction Manual and the Log Book.

Channel list

There are seven channel categories, each with its own letter and each handling different functions in the card.

- C-channels: General readout and configuration channels.
- d-channels: Channels relating to the DB402 vehicle detector.
- F-channels: Channels relating to settings for frequency converter, DB409
- L-channels: Channels relating to limit switches and timer control and the DB405 encoder.
- o-channels: Channels relating to output cards DB407 and DB410.
- P-channels: Channels relating to programmable inputs.
- r-channels: Channels relating to function of the DB411 radio card.

There is a reference column for each channel, showing where you can find more details and examples of how to use the channel, and the functions you can access with the channel.

Channels with a grey background are readout channels so they cannot be changed.

The  symbol means that the channel is a safety setting, and any change in value must be documented in the log book, with a name and date.

• General, C-channels

General readout channels

No.	Name	Range	Factory	Setting
C001	Software revision			
C004	Hardware revision			
C005	Voltage after stop circuit	00.0 – 30.0 V		
C014	Number of openings x1	000-999		
C015	Number of openings x1000	0000-9999		
C019	Time remaining to automatic closing	000.0-600.0 seconds		
C020	Most recent cause of motor stop			
	01	Limit switch motor 1 open		
	02	Limit switch motor 1 closed		
	03	Limit switch motor 2 open		
	04	Limit switch motor 2 closed		
	10	Stop		
	21	Photocell during opening movement		
	22	Photocell during closing movement		
	31	Loop 1 during opening movement		
	32	Loop 1 during closing movement		
	33	Loop 2 during opening movement		
	34	Loop 2 during closing movement		
	41	Safety edge opening reverse		
	42	Safety edge opening stop		
	43	Safety edge closing reverse		
	44	Safety edge closing stop		
	51	Photocell input 6 opening		
	52	Photocell input 6 closing		
	90	Loss of mains voltage		
	91	Low 24VDC		

General configuration channels

No.	Name	Range	Factory	Setting
▲ C033	Pulse/hold-to-run	0 - 5	5	
	0	Open and close with hold-to-run and load guard inactive		
	1	Open with pulse and close with hold-to-run and load guard active		
	2	Open with hold-to-run and close with pulse and load guard active		
	3	Open and close with pulse and load guard active		
	4	Open and close with hold-to-run and load guard active		
	5	Service mode, only internal open/close buttons with hold-to-run. Enables L001/2 to be set to 4, operation without limit switch.		
C063	Reverse priority during movement	0 - 3	1	
	0	None		
	1	Open		
	2	Close		
	3	Open and close		

Safety edge

No.	Name	Range	Factory	Setting
▲ C101	Safety edge acknowledgement SE.C1	0-1	0	
	0	Disabled		
	1	Enabled		
▲ C102	Output for self-test of external protection	0-4	0	
	0	Check disabled, open output		
	1	Closed to GND on activation, normally open		
	2	Closed to +24 VDC on activation, normally open		
	3	Open on activation, normally closed to GND		
	4	Open on activation, normally closed to +24 VDC		
▲ C103	Function of safety edge input during test of external safety edge unit	1 – 2	1	
	1	Low resistance during test		
	2	High resistance during test		
▲ C104	Connection and safety edge function	1-3	1	
	1	SE.C1 or SE.C2 can be connected to either motor 1 or motor 2. SE.O1 or SE.O2 can be connected to either motor 1 or motor 2. Both safety edges reverse/stop an active motor		
	2	SE.C1 and SE.O1 must be connected to motor 1 SE.C2 and SE.O2 must be connected to motor 2 The safety edge function is attached to the motor concerned		
	3	SE.C1 or SE.C2 can be connected to either motor 1 or motor 2. SE.O1 can be connected for protection function in opening for motor 1 and motor 2. The safety edges reverse/stop an active motor SE O2 stops an active motor in both opening and closing and overrides channel C142		
C105	Halved speed after activated safety edge. Only when using a frequency converter.	0-1	0	
	0	Disabled		
	1	Active		
▲ C111	Selects function for safety edge SE.C1	0-2	2	
	0	SE.C1 disabled		
	1	Limits according to set value in C115		
	2	Fixed limits between 5 kΩ and 15 kΩ		
▲ C112	Reverse/stop with activated safety edge SE.C1 (KSS)	1-2	1	
	1	Reverse		
	2	Stop		
▲ C113	Control of external protection connected to SE.C1	0-1	1	
	0	No check		
	1	Test of protection connected to SE.C1 if C102 is enabled		
C114	Reading impedance SE.C1	00.0-99.9 kΩ		
▲ C115	Setting impedance value for safety edge SE.C1 Set to 1 only at C111.	1.0-9.9 kΩ	8.2	

No.	Name	Range	Factory	Setting
▲ C121	Selects function for safety edge SE.C2	0-2	2	
	0	SE.C2 disabled		
	1	Limits according to set value in C125		
	2	Fixed limits between 5 kΩ and 15 kΩ		
▲ C122	Reverse/stop with activated safety edge SE.C2	1-2	1	
	1	Reverse		
	2	Stop		
▲ C123	Control of external protection connected to SE.C2	0-1	1	
	0	No check		
	1	Test of protection connected to SE.C2 if C102 is enabled		
C124	Reading impedance SE.C2	00.0-99.9 kΩ		
▲ C125	Setting impedance value for safety edge SE.C2 Set to 1 only at C121.	1.0-9.9 kΩ	8.2	
▲ C131	Selects function for SE.O1	0-2	0	
	0	SE.O1 disabled		
	1	Limits according to set value in C135		
	2	Fixed limits between 5 kΩ and 15 kΩ		
▲ C132	Reverse/stop with activated safety edge SE.O1	1-2	1	
	1	Reverse		
	2	Stop		
▲ C133	Control of external protection connected to SE.O1	0-1	1	
	0	No check		
	1	Test of protection connected to SE.O1 if C102 is enabled		
C134	Reading impedance SE.O1	00.0-99.9 kΩ		
▲ C135	Setting impedance value for safety edge SE.O1. Set to 1 only at C131.	1.0-9.9 kΩ	8.2	
▲ C141	Selects function for SE.O2	0-2	0	
	0	SE.O2 disabled		
	1	Limits according to set value in C135		
	2	Fixed limits between 5 kΩ and 15 kΩ		
▲ C142	Reverse/stop with activated safety edge SE.O2 Subordinate to channel C104	1-2	1	
	1	Reverse		
	2	Stop		
▲ C143	Control of external protection connected to SE.O2	0-1	1	
	0	No check		
	1	Test of protection connected to SE.O2 if C102 is enabled		
C144	Reading impedance SE.O2	00.0-99.9 kΩ		
▲ C145	Setting impedance value for safety edge SE.O2. Set to 1 only at C141.	1.0-9.9 kΩ	8.2	

Load guard and motor settings

No.	Name	Range	Factory	Setting
▲ C200	Load guard function	0 – 4	3	
	0	Disabled. Service and troubleshooting only		
	1	Reverse when closing, stop when opening		
	2	Stop when closing and reverse when opening		
	3	Reverse when closing and opening		
	4	Stop when closing and opening		
▲ C202	Type of power supply	0 - 5	0	
	0	3x400V with neutral		
	1	3x230V without neutral		
	2	1x230V with neutral, asymmetrical		
	3	3x400 V without neutral (see separate instructions)		
	4	1x230V with neutral, frequency converter (See DB409)		
	5	1x230V with neutral, asymmetrical		
C205	Load guard for personal protection active during the closing movement	0-1	1	
	0	Disabled		
	1	Active		
▲ C211	Load guard delay	0.01-2.50 seconds	0.06	
▲ C212	Load guard, connection delay on start, all starts	0.1-2.5 seconds	1.0	
▲ C221	Motor protection delay	3.0-5.0 seconds	5.0	
▲ C230 ^{AC}	Set motor power readout for personal protection, motor 1	0.00 and 0.12-0.35 kW	0.20	
C231 ^A	Motor power readout, motor 1	0.00-1.99 kW		
▲ C232 ^A	Set load guard limit for motor 1 opening	0.05-1.99 kW	0.70	
▲ C233 ^A	Set load guard limit for motor 1 closing	0.05-1.99 kW	0.70	
▲ C240 ^{BC}	Set motor power readout for personal protection, motor 2	0.00 and 0.12-0.35 kW	0.20	
C241 ^B	Motor power readout, motor 2	0.00-1.99 kW		
▲ C242 ^B	Set load guard limit for motor 2 opening	0.05-1.99 kW	0.70	
▲ C243 ^B	Set load guard limit for motor 2 closing	0.05-1.99 kW	0.70	
C251 ^A	Motor current readout, motor 1	0.0-20.0A		
▲ C252 ^A	Set motor current readout, motor 1 opening	0.0 and 0.5-6.0A	0.8	
▲ C253 ^A	Set motor current readout, motor 1 closing	0.0 and 0.5-6.0A	0.8	
C261 ^B	Motor current readout, motor 2	0.0-20.0A		
▲ C262 ^B	Set motor current readout, motor 2 opening	0.0 and 0.5-6.0A	0.8	
▲ C263 ^B	Set motor current readout, motor 2 closing	0.0 and 0.5-6.0A	0.8	
C271 ^{AC}	Power factor readout motor 1	0.00-0.99 cos φ		
C281 ^{BC}	Power factor readout motor 2	0.00-0.99 cos φ		

A = Not shown as L001 = 0; B = Not shown as L002 = 0, C = Not shown as C202 = 4

Photocell

No.	Name	Range	Factory	Setting
C340	Safety function in closing movement	0 – 3	1	
	0	Disabled		
	1	Reverse to fully open		
	2	Stop with automatic restart of automatic closing		
	3	Stop, wait for new control signal or time in C520 and thereafter automatic closing.		
C341	Safety during run-on time or disengagement angle in closing movement.	0-1	1	
	0	Disabled when both halves are in run-on or disengagement angle		
	1	Activated according to C340		
C342	Safety function in opening movement	0 – 4	0	
	0	Disabled		
	1	Reverse to fully closed.		
	2	Stop with automatic restart of automatic closing		
	3	Stop, wait for new control signal or time in C520 and thereafter automatic closing.		
	4	Stop with restart of opening		
C343	Check of external protection connected to input PHOTO	0-1	1	
	0	No check		
	1	Test of break in continuity for protection connected to input PHOTO		
C351	Photocell closing after time in C510	0-1	0	
	0	Disabled		
	1	Enabled and subordinated to C340		
C354	Type of photocell closing	1-2	2	
	1	Closes immediately if photosensor is disabled		
	2	Continues to fully open, then closes if photocell is disabled		

General time channels.

No.	Name	Range	Factory	Setting
▲ C436	Type of stop during run-on time when closing, subordinated to C448 and C449	0-3	3	
	0	Time		
	1	Time or load guard		
	2	Time or safety edge		
	3	Time, load guard or safety edge		
▲ C448	Safety edge reverse during run-on while closing, L117, L127, L213, L223	0-2	2	
	0	Function disabled		
	1	Safety edge reverse during run-on time		
	2	Safety edge reverse during run-on time and during the time in C492		
▲ C449	Reverse during run-on time when load guard is triggered, L117, L127, L213, L223	0-1	1	
	0	Disabled		
	1	Reversing in closing movement		
C460	Time delay before second motor starts. Start of motor 2 is delayed during opening Start of motor 1 is delayed during closing	0.1-9.9 seconds	0.1	
C470	Time delay before first motor starts. Start of motor 1 is delayed during opening Start of motor 2 is delayed during closing	0.00-0.99 seconds	0.00	
▲ C492	Change of direction delayed if PHOTO, LOOP1 LOOP2 or control signal are activated.	0.1-4.0 seconds	0.8	
▲ C493	Reverse delay if safety edge or load guard are activated	0.03-2.00 seconds	0.10	
▲ C494	Closing time after activated protection function, safety edge or load guard, while opening	0.1-2.0 seconds	1.0	
C495	Engagement time for brake, motor 1	00, 10-50 ms	00	
C496	Engagement time for brake, motor 2	00, 10-50 ms	00	

Automatic closing

No.	Name	Range	Factory	Setting
C500	Time before automatic closing 000,0 means disabled function	000.0-600.0 seconds	000.0	
C510	Time before closing, after passage, on photocell closing and loop closing. Subordinated to C351, d151 and d251	00-99 seconds	00	
C520	Blocking time for automatic closing after the stop button is activated. 000 means disabled function.	000 and 020-600 seconds	000	
C591	Closing using photocell and loops. See also C351, d151 and d251.	00-14	00	
	00	Disabled		
	01	Presence detection, LOOP1 must first be activated, closes when LOOP1 is clear.		
	02	Presence detection, LOOP2 must first be activated, closes when LOOP2 is clear.		
	03	Presence detection, LOOP1 or LOOP2 must first be activated, closes when either LOOP1 or LOOP2 is clear.		
	04	Presence detection, PHOTO must first be activated, closes when PHOTO is clear.		
	05	Presence detection, PHOTO and LOOP1 must first be activated simultaneously, then close when either PHOTO or LOOP1 is clear.		
	06	Presence detection, PHOTO and LOOP2 must first be activated simultaneously, then close when either PHOTO or LOOP2 is clear.		
	07	Presence detection, PHOTO, LOOP1 and LOOP2 must first be activated simultaneously, close when either PHOTO, LOOP1 or LOOP2 is clear.		
	08	Presence detection, LOOP1 and LOOP2 must first be activated simultaneously, close when either LOOP1 or LOOP2 is clear.		
	09	Direction sensing, LOOP1 must first be activated, during the time LOOP2 must be activated, then LOOP1 must be disabled, closes when LOOP2 is clear.		
	10	Direction sensing, LOOP1 must first be activated, during the time PHOTO must be activated, then LOOP1 must be disabled, closes when PHOTO is clear.		
	11	Direction sensing, LOOP2 must first be activated, during the time LOOP1 must be activated, then LOOP2 must be disabled, closes when LOOP1 is clear.		
	12	Direction sensing, LOOP2 must first be activated, during the time PHOTO must be activated, then LOOP2 must be disabled, closes when PHOTO is clear.		
	13	Direction sensing, PHOTO must first be activated, during the time LOOP1 must be activated, then PHOTO must be disabled, closes when LOOP1 is clear.		
	14	Direction sensing, PHOTO must first be activated, during the time LOOP2 must be activated, then PHOTO must be disabled, closes when LOOP2 is clear.		

Communication

No.	Name	Range	Factory	Setting
C600	Choice of communication	0-2	0	
	0	Disabled		
	1	Interlock		
	2	Simply connect		

Interlock

C610	Choice of unit address	1-2	2	
C614	Block of local door	0-3	0	
	0	No blocking of the local door depending on position of remote door		
	1	Block of open on local door until remote door is closed		
	2	Block of open on local door until remote door is open		
	3	Blocking of close on local door until remote door is closed		
C615	In block of local door	0-3	3	
	0	Stopped local door does not disable blocking of remote door. Local door does not remember open and stop		
	1	Stopped local door does not disable blocking of remote door. Local door remembers open and stop.		
	2	Stopped local door disables blocking of remote door. Local door does not remember open and stop		
	3	Stopped local door disables blocking of remote door. Local door remembers open and stop		

Simply connect

C620	Choice of unit address	1-4	1	
C621	Channel access	0-1	1	
	0	Reading only		
	1	Reading and writing		
C630	Simply connect pin code	0000-9999	0000	

Configuration

C700	Selection of application	0-7	2	
	0	Not selected		
	1	Gate, Swing gate		
	2	Gate, Folding gate		
	3	Gate, Sliding gate		
	4	Door, Swing door		
	5	Door, Folding door		
	6	Door, Sliding door		
	7	Barrier		
C701	Magnetic lock control DB310	0-1	0	
	0	Not installed, does not affect display of channels		
	1	Installed		
C702	Vehicle detector DB402	0-1	0	
	0	Not installed, d-channels not displayed		
	1	Installed		
C705	Encoder card DB405	0-1	0	
	0	Not installed, does not affect display of L-channels		
	1	Installed, the settings in L001 and L002 also control display of L-channels		

No.	Name	Range	Factory	Setting
C707	Output card DB407	0-1	0	
	0	Not installed, o-channels not displayed		
	1	Installed		
C709	Frequency converter card DB409	0-1	0	
	0	Not installed, does not affect display of F-channels		
	1	Installed, selection in channel C202 also controls display of the F-channels		
C710	Output channel DB410, o-channels not displayed	0-1	0	
	0	Not installed		
	1	Installed		
C711	Radio card DB411	0-1	0	
	0	Not installed, r-channels not displayed		
	1	Installed		
C712	Adapter card DB512	0-1	0	
	0	Not installed, does not affect display of channels		
	1	Installed		

Service channels

C900	Service channel, for service personnel only	Random number	000-999		
C901	Service channel, for service personnel only.		00-99	00	
	00	No function selected			
	10	Channel values locked for editing.			
	80	Erasure of error code list in channel C903			
C902	Service channel, for service personnel only, checksum		0000-FFFF		
C903	Error code list showing the most recent error events.				
	_____	Start of the list, followed by the latest message when the minus button is pressed.			
	E003-E976	Error messages, use + and - buttons to step up or down.			
	n021-n074	Message, use + and - buttons to step up or down.			
	_____	End of the list, followed by the oldest message when the plus button is pressed.			
C904	Message in display and in error code list.		0-1	1	
	0	Messages are neither displayed nor stored in the error code list			
	1	Messages are displayed and stored in the error code list			
C999	Selection of channel display		0-4	2	
	0	No restriction on channel display.			
	1	Displays only channels that differ from factory settings, use + and - to step up or down. The button on the far left is used for rapid stepping between the channel groups, has no function in this position.			
	2	Displays only the channels needed for setting open and closed position and motor protection.			
	3	Displays only the channels needed for setting of load guard, motor protection, gear ratio, limit switch type and selection of application.			
	4	Displays channels for selecting application and add-on boards.			

- Vehicle detector DB402, d-channels

- Vehicle loop 1

Note that the display of the d-channels is determined by the setting in C702

No.	Name	Range	Factory	Setting
d100	Vehicle loop 1	0-1	0	
	0	Disabled		
	1	Enabled		
d101	Loop reading x1	000-999		
d102	Loop reading x1000	00-99		
d103	Activation by passing vehicle	000-999		
d110	Detection limit for a vehicle in the loop	05-99	15	
d111	Difference between on and off in the loop	00-50	03	
d120	Loop presence reset	000 and 005-240 minutes	120	
d121	Fast loop presence reset	00-99 seconds	00	
d131	Compensation for activation from door half motor 1 on the loop in the closed position	00-50	03	
d132	Compensation for activation from door half motor 2 on the loop in the closed position	00-50	03	
d140	Safety function in closing movement	0 - 4	1	
	0	Disabled		
	1	Reverse		
	2	Stop with automatic restart of automatic closing		
	3	Stop without automatic restart of automatic closing, wait for new control signal		
	4	Safety only in open position. Used when the gate passes over the loop in the closing movement.		
d141	Safety during run-on time or disengagement angle in closing movement.	0-1	1	
	0	Disabled		
	1	Activated according to P140		
d142	Safety function in opening movement	0 - 4	0	
	0	Disabled		
	1	Reverse to fully closed		
	2	Stop with automatic restart of automatic closing		
	3	Stop without automatic restart of automatic closing, wait for new control signal		
	4	Safety only in closed position. Used when the gate passes over the loop in the opening movement.		
d151	Loop closing after time in C510	0-1	0	
	0	Disabled		
	1	Active		
d154	Type of loop closing	1-2	2	
	1	Closes immediately when loop is disabled		
	2	Continues to fully open, then closes when the loop is disabled		

No.	Name	Range	Factory	Setting
d160	Control function	0 - 1	0	
	0	Disabled		
	1	Open		
d161	Type of control signal when activated	1 - 2	1	
	1	Pulse		
	2	Constant signal when loop is activated		
d162	Half operation	1 - 3	3	
	1	Motor 1		
	2	Motor 2		
	3	Motors 1 and 2		
d163	Limited opening	0 - 1	0	
	0	Disabled		
	1	Opening according to set time in channel L216/L226 or number of degrees in L116/L126 if encoder is used.		
d170	Allows the opening function, via LOOP1, using a programmable input.	0-6	0	
	0	Disabled, normal opening/closing function. (Programmable input has no function for LOOP1)		
	1	Opening possible only if there is a signal at programmable input 1		
	2	Opening possible only if there is a signal at programmable input 2		
	3	Opening possible only if there is a signal at programmable input 3		
	4	Opening possible only if there is a signal at programmable input 4		
	5	Opening possible only if there is a signal at programmable input 5		
	6	Opening possible only if there is a signal at programmable input 6		
d175	Opening via loop after activation during set time, the loop will not open the gate until it has been activated for the set time.	0.0-9.9 seconds	0.0	
d190	Interlock opening	0 - 1	0	
	0	Disabled		
	1	Sends a normal open signal to the remote door		

Vehicle loop 2

Note that the display of the d-channels is determined by the setting in C702

No.	Name	Range	Factory	Setting
d200	Vehicle loop 2	0-1	0	
	0	Disabled		
	1	Enabled		
d201	Loop reading x1	000-999		
d202	Loop reading x1000	00-99		
d203	Activation from passing vehicle	000-999		
d210	Detection limit for a vehicle in the loop	05-99	15	
d211	Difference between on and off in the loop	00-50	03	
d220	Loop presence reset	000 and 005-240 minutes	120	
d221	Fast loop presence reset	00-99 seconds	00	
d231	Compensation for activation from door half motor 1 on the loop in the closed position	00-50	03	
d232	Compensation for activation from door half motor 2 on the loop in the closed position	00-50	03	
d240	Safety function in closing movement	0 - 4	1	
	0	Disabled		
	1	Reverse		
	2	Stop with automatic restart of automatic closing		
	3	Stop without automatic restart of automatic closing, wait for new control signal		
	4	Safety only in open position. Used when the gate passes over the loop in the closing movement.		
d241	Safety during run-on time or disengagement angle in closing movement.	0-1	1	
	0	Disabled		
	1	Activated according to P240		
d242	Safety function in opening movement	0 - 4	0	
	0	Disabled		
	1	Reverse to fully closed		
	2	Stop with automatic restart of automatic closing		
	3	Stop without automatic restart of automatic closing, wait for new control signal		
	4	Safety only in closed position. Used when the gate passes over the loop in the opening movement.		
d251	Loop closing after time in C510	0-1	0	
	0	Disabled		
	1	Enabled		
d254	Type of loop closing	1-2	2	
	1	Close immediately when loop is disabled		
	2	Continues to fully open, then closes when the loop is disabled		

No.	Name	Range	Factory	Setting
d260	Control function	0 - 1	0	
	0	Disabled		
	1	Open		
d261	Type of control signal when activated	1 - 2	1	
	1	Pulse		
	2	Signal when loop is activated		
d262	Half operation	1 - 3	3	
	1	Motor 1		
	2	Motor 2		
	3	Motors 1 and 2		
d263	Limited opening	0 - 1	0	
	0	Disabled		
	1	Opening according to set time in channel L216/L226 or number of degrees in L116/L126 if encoder is used.		
d270	Allows the opening function, via LOOP2, using a programmable input.	0-6	0	
	0	Disabled, normal opening/closing function. (Programmable input has no function for LOOP2)		
	1	Opening possible only if there is a signal at programmable input 1		
	2	Opening possible only if there is a signal at programmable input 2		
	3	Opening possible only if there is a signal at programmable input 3		
	4	Opening possible only if there is a signal at programmable input 4		
	5	Opening possible only if there is a signal at programmable input 5		
	6	Opening possible only if there is a signal at programmable input 6		
d275	Opening via loop after activation during set time, the loop will not open the gate until it has been activated for the set time.	0.0-9.9 seconds	0.0	
d290	Interlock opening	0 - 1	0	
	0	Disabled		
	1	Sends a normal open signal to the remote door		

- Frequency converter, F-channels

No.	Name	Range	Factory	Setting
F001	Communication with frequency converter	0-1	1	
	0	Communication disabled		
	1	Communication activated		
F002	Acceleration time from closed position motors 1 and 2 (from 0-100 Hz)	0.5-9.9 seconds	2.0 sec	
F003	Acceleration time in all movements except at closed position motors 1 and 2 (from 0-100Hz)	0.5-9.9 seconds	4.0 sec	
F004	Acceleration time when P500 is set to 2 and the input is activated, battery backup	5.0-12.0 seconds	7.0 sec	
F005	Retardation time with limit switch and change of direction motors 1 and 2 (from 1000-0 Hz)	0.5-9.9 seconds	4.0 sec	
F006	Retardation time with photocell and vehicle loops motors 1 and 2 (from 1000Hz)	0.5-9.9 seconds	2.0 sec	
F008	Low-speed frequency for opening movement	5-20 Hz	5 Hz	
F009	Low-speed frequency for closing movement	5-20 Hz	10 Hz	
F012	Opening frequency / Opening speed for motor 1	21-99 Hz	50 Hz	
F013	Closing frequency / Closing speed for motor 1	21-99 Hz	30 Hz	
F014*	Number of degrees with low-speed frequency before open position for motor 1	0-60	0	
F015*	Number of degrees with low-speed frequency before closed position for motor 1	0-60	0	
F022	Opening frequency / Opening speed for motor 2	21-99 Hz	50 Hz	
F023	Closing frequency / Closing speed for motor 2	21-99 Hz	30 Hz	
F024*	Number of degrees with low-speed frequency before open position for motor 2	0-60	0	
F025*	Number of degrees with low-speed frequency before closed position for motor 2	0-60	0	

* = Appears only when L001 and/or L002 are set to 1 encoder or 4, hold-to-run without limit switch.

F-channels are shown only when C2020=4, frequency converter

No.	Name	Range	Factory	Setting
F030*	Choice of ratio for motor 1	0-9	0	
	0	Not selected, in this position the motor only rotates at 25Hz		
	1	MK with pulleys 40/71 (gear ratio 1318:1)		
	2	MK with pulleys 50/71 (gear ratio 1098:1)		
	3	MK with pulleys 71/71 (gear ratio 791:1)		
	4	MK with pulleys 100/71 (gear ratio 565:1)		
	5	MK with pulleys 125/71 (gear ratio 456:1)		
	6	MK with pulleys 140/71 (gear ratio 409:1)		
	7	MT (ratio 791:1)		
	8	M10 with pulleys 71/71, motor 1400 rev/min (gear ratio 2970:1)		
	9	M10 with pulleys 71/71, motor 2800 rev/min (gear ratio 1485:1)		
F031*	Measured ratio motor 1. Only when F030=0.	0-2000		
F040*	Choice of ratio for motor 2	0-9	0	
	0	Not selected, in this position the motor only rotates at 25Hz		
	1	MK with pulleys 40/71 (gear ratio 1318:1)		
	2	MK with pulleys 50/71 (gear ratio 1098:1)		
	3	MK with pulleys 71/71 (gear ratio 791:1)		
	4	MK with pulleys 100/71 (gear ratio 565:1)		
	5	MK with pulleys 125/71 (gear ratio 456:1)		
	6	MK with pulleys 140/71 (gear ratio 409:1)		
	7	MT (ratio 791:1)		
	8	M10 with pulleys 71/71, motor 1400 rev/min (gear ratio 2970:1)		
	9	M10 with pulleys 71/71, motor 2800 rev/min (gear ratio 1485:1)		
F041*	Measured ratio motor 2. Only when F040=0.	0-2000		

* = Appears only when L001 and/or L002 are set to 1 encoder or 4, hold-to-run without limit switch.
F-channels are shown only when C2020=4, frequency converter

- Limit switches, L-channels

No.	Name	Range	Factory	Setting
L001	Choice of limit switch type for motor 1	0-3	0	
	0	Disabled		
	1	Encoder		
	2	Limit switch		
	3	Time		
	4	Hold-to-run without limit switches. NOTE! Only one half at a time can be run. C033 must be set to 5.		
L002	Choice of limit switch type for motor 2	0-3	0	
	0	Disabled		
	1	Encoder		
	2	Limit switch		
	3	Time		
	4	Hold-to-run without limit switches. NOTE! Only one half at a time can be run. C033 must be set to 5.		

Encoder

L110 ¹	Position of motor 1, viewed from the motor side	0-2	1	
	0	Disabled		
	1	Left		
	2	Right		
L111 ¹	Position angle readout motor 1	000-360 degrees		
L112 ¹	Angle for open position, motor 1	145-330 degrees	260	
L113 ¹	Angle for closed position, motor 1	015-200 degrees	90	
L116 ¹	Angle for limited opening, motor 1.	0-200 degrees	45	
L117 ¹	Angle for disconnection of safety edge, load guard and photocell from the end of the closing movement, motor 1 in combination with C436, C341 and C448	0-30 degrees	0	
L118 ¹	Angle for the disconnection of vehicle loops from the end of the closing movement, motor 1 in combination with d141 or d241.	0-45 degrees	0	
L120 ²	Position of motor 2, viewed from the motor side	0-2	2	
	0	Disabled		
	1	Left		
	2	Right		
L121 ²	Position angle readout motor 2	000-360 degrees		
L122 ²	Angle for open position, motor 2	145-330 degrees	260	
L123 ²	Angle for closed position, motor 2	015-200 degrees	90	
L126 ²	Angle for limited opening, motor 2.	0-200 degrees	45	
L127 ²	Angle for disconnection of safety edge, load guard and photocell from the end of the closing movement, motor 2 in combination with C436, C341 and C448	0-30 degrees	0	
L128 ²	Angle for the disconnection of vehicle loops from the end of the closing movement, motor 2 in combination with d141 or d241.	0-45 degrees	0	

1 = Only displayed if L001 is set to 1 or 4. 2 = Only displayed if L002 is set to 1 or 4.

Limit switch

No.	Name	Range	Factory	Setting
L203 ^A	Setting limited running time (Not used with encoder)	001-999 seconds	001	
L211 ^A	Running time readout, motor 1	000-999 seconds		
L212 ^{AB}	Run-on time following limit switch open, motor 1	0.00-7.99 seconds	0.00	
L213 ^A	Run-on time following limit switch closed, motor 1	0.00-7.99 seconds	0.00	
L216 ^A	Set limited opening, motor 1 with limit switch	00.3-99.9 seconds	05.0	
L221 ^A	Running time readout, motor 2	000-999 seconds		
L222 ^{AC}	Run-on time following limit switch open, motor 2	0.00-7.99 seconds	0.00	
L223 ^A	Run-on time following limit switch closed, motor 2	0.00-7.99 seconds	0.00	
L226 ^A	Set limited opening, motor 2 with limit switch	00.3-99.9 seconds	05.0	

Time control

L311	Time readout for motor 1	00.1-99.9 seconds		
L312 ^A	Set time for motor 1	00.1-99.9 seconds	00.1	
L321	Time readout for motor 2	00.1-99.9 seconds		
L322 ^A	Set time for motor 2	00.1-99.9 seconds	00.1	

A = Only displayed if L001 and/or L002 are set to 2 or 3.

B = Only displayed if L001 = 1 and C202 = 4, frequency converter

C = Only displayed if L002 = 1 and C202 = 4, frequency converter.

- Output card DB407 and DB410, o-channels

Programmable output 1

Note that the display of the o-channels is determined by the setting in C707 and C710

No.	Name	Range	Factory	Setting
o100	Function of output 1	0 - 4	1	
	0	Disabled		
	1	Position indication/Movement/Warning. Signal as configured in o110 – o122		
	2	Presence detection/Direction sensing. Signal as configured in o191		
	3	Lock		
	4	Alarm output Signal as configured in o130 – o142		
o110	Open position	0 - 1	1	
	0	Disabled		
	1	Constant signal		
o111	Mid position	0 - 1	0	
	0	Disabled		
	1	Constant signal		
o112	Closed position	0 - 1	0	
	0	Disabled		
	1	Constant signal		
o113	Movement	0 - 4	4	
	0	Disabled		
	1	Constant signal in the opening movement		
	2	Constant signal in the closing movement		
	3	Constant signal in the opening and closing movement		
	4	No signal during movement, used in combination with o110, o111 and o112.		
o114	Delayed switch-off Switch off after the specified time Used for example for lighting that is switched off a specified time after closing.	000.0-600.0 seconds	000.0	
o120	Warning time before start	000.0-600.0 seconds	000.0	
o121	Warning function in combination with o120	1 - 4	2	
	1	Constant signal before automatic closing		
	2	Constant signal before park and automatic closing		
	3	Constant signal before close signal, park and automatic closing		
	4	Constant signal before all signals		
o122	Function during warning time	1 - 2	1	
	1	Output signal disabled during warning in other output		
	2	Output signal as configured in o110-o113		

No.	Name	Range	Factory	Setting
o130*	Alarm if there is an error as configured in o131-o142. The alarm is activated for at least the time set in this channel.	000.0-600.0 seconds	000.0	
o131*	Alarm for faulty safety edge. Time as in o130.	0 - 1	0	
	0	Disabled		
	1	Constant signal		
o132*	Alarm for critical error message in display	0-1	0	
	0	Disabled		
	1	Constant signal		
o133*	Alarm if stop circuit interrupted	0 - 1	0	
	0	Disabled		
	1	Constant signal		
o134*	Alarm if door open	0 - 1	0	
	0	Disabled		
	1	Constant signal		
o135*	Alarm if door is in mid position	0 - 1	0	
	0	Disabled		
	1	Constant signal		
o136*	Alarm if door is in closed position	0 - 1	0	
	0	Disabled		
	1	Constant signal		
o137*	Alarm if vehicle loop 1 is activated	0 - 1	0	
	0	Disabled		
	1	Constant signal		
o138*	Alarm if vehicle loop 2 is activated	0 - 1	0	
	0	Disabled		
	1	Constant signal		
o139*	Alarm if photocell interrupted	0 - 1	0	
	0	Disabled		
	1	Constant signal		
o142*	Alarm for uncritical error message in display. E008, E015, E028, E046, E047, E048, E201, E202, E206, E207, E931, E932	0-1	0	
	0	Disabled		
	1	Constant signal		
o183	Inversion of contact function for output	1 - 2	1	
	1	Normally open, NO		
	2	Normally closed, NC		

* = Only when o100 is set to 4.

No.	Name	Range	Factory	Setting
o191	Function when LOOP2, LOOP2 or PHOTO activated	01 - 14	01	
	01	Presence detection. Signal when LOOP1 is activated, remains until LOOP1 is clear.		
	02	Presence detection. Signal when LOOP2 is activated, remains until LOOP2 is clear.		
	03	Presence detection. Signal when both LOOP1 and LOOP2 are activated, remains until either LOOP1 or LOOP2 is clear.		
	04	Presence detection. Signal when PHOTO is activated, remains until PHOTO is clear.		
	05	Presence detection. Signal when PHOTO and LOOP1 are activated, remains until either PHOTO or LOOP1 is clear.		
	06	Presence detection. Signal when PHOTO and LOOP2 are activated, remains until either PHOTO or LOOP2 is clear.		
	07	Presence detection. Signal when PHOTO, LOOP1 and LOOP2 are activated, remains until either PHOTO, LOOP1 or LOOP2 is clear.		
	08	Presence detection. Signal when either LOOP1 or LOOP2 is activated, remains until either LOOP1 or LOOP2 is clear.		
	09	Direction sensing. Signal when first LOOP1 and then LOOP2 are activated. The signal remains until LOOP2 is clear.		
	10	Direction sensing. Signal when first LOOP1 and then PHOTO are activated. The signal remains until PHOTO is clear.		
	11	Direction sensing. Signal when first LOOP2 and then LOOP1 are activated. The signal remains until LOOP1 is clear.		
	12	Direction sensing. Signal when first LOOP2 and then PHOTO are activated. The signal remains until PHOTO is clear.		
	13	Direction sensing. Signal when first PHOTO and then LOOP1 are activated. The signal remains until LOOP1 is clear.		
	14	Direction sensing. Signal when first PHOTO and then LOOP2 are activated. The signal remains until LOOP2 is clear.		

Programmable output 2

Note that the display of the o-channels is determined by the setting in C707 and C710

No.	Name	Range	Factory	Setting
o200	Function of output 2	0 - 4	1	
	0	Disabled		
	1	Position indication/Movement/Warning. Signal as configured in o210 – o222		
	2	Presence detection/Direction sensing. Signal as configured in o291		
	3	Lock		
	4	Alarm output. Signal as configured in o230 – o242		
o210	Open position	0 - 1	0	
	0	Disabled		
	1	Constant signal		
o211	Mid position	0 - 1	0	
	0	Disabled		
	1	Constant signal		
o212	Closed position	0 - 1	1	
	0	Disabled		
	1	Constant signal		
o213	Movement	0 - 4	4	
	0	Disabled		
	1	Constant signal in the opening movement		
	2	Constant signal in the closing movement		
	3	Constant signal in the opening and closing movement		
	4	No signal during movement, used in combination with o210, o211 and o212.		
o214	Delayed switch-off Switch off after the specified time Used for example for lighting that is switched off a specified time after closing	000.0-600.0 seconds	000.0	
o220	Warning time before start	000.0-600.0 seconds	000.0	
o221	Warning function in combination with o220	1 - 4	2	
	1	Constant signal before automatic closing		
	2	Constant signal before park and automatic closing		
	3	Constant signal before close signal, park and automatic closing		
	4	Constant signal before all signals		
o222	Function during warning time	1 - 2	1	
	1	Output signal disabled during warning in other output		
	2	Output signal as configured in o210-o213		

No.	Name	Range	Factory	Setting
o230*	Alarm if there is an error as configured in o231-o242. The alarm is activated for at least the time set in this channel.	000.0-600.0 seconds	000.0	
o231*	Alarm for faulty safety edge. Time as in o230.	0 - 1	0	
	0	Constant signal		
	1	Active		
o232*	Alarm for uncritical error message in display	0-1	0	
	0	Constant signal		
	1	Active		
o233*	Alarm if stop circuit interrupted	0 - 1	0	
	0	Disabled		
	1	Constant signal		
o234*	Alarm if door open	0 - 1	0	
	0	Disabled		
	1	Constant signal		
o235*	Alarm if door is in mid position	0 - 1	0	
	0	Disabled		
	1	Constant signal		
o236*	Alarm if door is in closed position	0 - 1	0	
	0	Disabled		
	1	Constant signal		
o237*	Alarm if vehicle loop 1 is activated	0 - 1	0	
	0	Disabled		
	1	Constant signal		
o238*	Alarm if vehicle loop 2 is activated	0 - 1	0	
	0	Disabled		
	1	Constant signal		
o239*	Alarm if photocell interrupted	0 - 1	0	
	0	Disabled		
	1	Constant signal		
o242*	Alarm for uncritical error message in display. E008, E015, E028, E046, E047, E048, E201, E202, E206, E207, E931, E932	0-1	0	
	0	Disabled		
	1	Constant signal		
o283	Inversion of contact function for output	1 - 2	1	
	1	Normally open, NO		
	2	Normally closed, NC		

* = Only when o200 is set to 4.

No.	Name	Range	Factory	Setting
o291	Function when SL.1, SL.2 or photocell/loop activated	01 - 14	01	
	01	Presence detection. Signal when LOOP1 is activated, remains until LOOP1 is clear.		
	02	Presence detection. Signal when LOOP2 is activated, remains until LOOP2 is clear.		
	03	Presence detection. Signal when both LOOP1 and LOOP2 are activated, remains until either LOOP1 or LOOP2 is clear.		
	04	Presence detection. Signal when PHOTO is activated, remains until PHOTO is clear.		
	05	Presence detection. Signal when PHOTO and LOOP1 are activated, remains until either PHOTO or LOOP1 is clear.		
	06	Presence detection. Signal when PHOTO and LOOP2 are activated, remains until either PHOTO or LOOP2 is clear.		
	07	Presence detection. Signal when PHOTO, LOOP1 and LOOP2 are activated, remains until either PHOTO, LOOP1 or LOOP2 is clear.		
	08	Presence detection. Signal when either LOOP1 or LOOP2 is activated, remains until either LOOP1 or LOOP2 is clear.		
	09	Direction sensing. Signal when first LOOP1 and then LOOP2 are activated. The signal remains until LOOP2 is clear.		
	10	Direction sensing. Signal when first LOOP1 and then PHOTO are activated. The signal remains until PHOTO is clear.		
	11	Direction sensing. Signal when first LOOP2 and then LOOP1 are activated. The signal remains until LOOP1 is clear.		
	12	Direction sensing. Signal when first LOOP2 and then PHOTO are activated. The signal remains until PHOTO is clear.		
	13	Direction sensing. Signal when first PHOTO and then LOOP1 are activated. The signal remains until LOOP1 is clear.		
	14	Direction sensing. Signal when first PHOTO and then LOOP2 are activated. The signal remains until LOOP2 is clear.		

Programmable output 3

Note that the display of the o-channels is determined by the setting in C707 and C710

No.	Name	Range	Factory	Setting
o300	Function of output 3	0 - 4	1	
	0	Disabled		
	1	Position indication/Movement/Warning. Signal as configured in o310 – o322		
	2	Presence detection/Direction sensing. Signal as configured in o391		
	3	Lock		
	4	Alarm output. Signal as configured in o330 – o342		
o310	Open position	0 - 1	1	
	0	Disabled		
	1	Constant signal		
o311	Mid position	0 - 1	0	
	0	Disabled		
	1	Constant signal		
o312	Closed position	0 - 1	0	
	0	Disabled		
	1	Constant signal		
o313	Movement	0 - 4	4	
	0	Disabled		
	1	Constant signal in the opening movement		
	2	Constant signal in the closing movement		
	3	Constant signal in the opening and closing movement		
	4	No signal during movement, used in combination with o310, o311 and o312.		
o314	Delayed switch-off Switch off after the specified time Used for example for lighting that is switched off a specified time after closing	000.0-600.0 seconds	000.0	
o320	Warning time before start	000.0-600.0 seconds	000.0	
o321	Warning function in combination with o320	1 - 4	2	
	1	Constant signal before automatic closing		
	2	Constant signal before park and automatic closing		
	3	Constant signal before close signal, park and automatic closing		
	4	Constant signal before all signals		
o322	Function during warning time	1 - 2	1	
	1	Output signal disabled during warning in other output		
	2	Signal as configured in o310-o313		

No.	Name	Range	Factory	Setting
o330*	Alarm if there is an error as configured in o331-o342. The alarm is activated for at least the time set in this channel.	000.0-600.0 seconds	000.0	
o331*	Alarm for faulty safety edge. Time as in o330.	0 - 1	0	
	0	Disabled		
	1	Constant signal		
o332*	Alarm for critical error message in display	0-1	0	
	0	Disabled		
	1	Constant signal		
o333*	Alarm if stop circuit interrupted	0 - 1	0	
	0	Disabled		
	1	Constant signal		
o334*	Alarm if door open	0 - 1	0	
	0	Disabled		
	1	Constant signal		
o335*	Alarm if door is in mid position	0 - 1	0	
	0	Disabled		
	1	Constant signal		
o336*	Alarm if door is in closed position	0 - 1	0	
	0	Disabled		
	1	Constant signal		
o337*	Alarm if vehicle loop 1 is activated	0 - 1	0	
	0	Disabled		
	1	Constant signal		
o338*	Alarm if vehicle loop 2 is activated	0 - 1	0	
	0	Disabled		
	1	Constant signal		
o339*	Alarm if photocell interrupted	0 - 1	0	
	0	Disabled		
	1	Constant signal		
o342*	Alarm for uncritical error message in display. E008, E015, E028, E046, E047, E048, E201, E202, E206, E207, E931, E932	0-1	0	
	0	Disabled		
	1	Constant signal		
o383	Inversion of contact function for output	1 - 2	1	
	1	Normally open, NO		
	2	Normally closed, NC		

* = Only when o300 is set to 4.

No.	Name	Range	Factory	Setting
o391	Function when SL.1, SL.2 or photocell/loop activated	01 - 14	01	
	01	Presence detection. Signal when LOOP1 is activated, remains until LOOP1 is clear.		
	02	Presence detection. Signal when LOOP2 is activated, remains until LOOP2 is clear.		
	03	Presence detection. Signal when both LOOP1 and LOOP2 are activated, remains until either LOOP1 or LOOP2 is clear.		
	04	Presence detection. Signal when PHOTO is activated, remains until PHOTO is clear.		
	05	Presence detection. Signal when PHOTO and LOOP1 are activated, remains until either PHOTO or LOOP1 is clear.		
	06	Presence detection. Signal when PHOTO and LOOP2 are activated, remains until either PHOTO or LOOP2 is clear.		
	07	Presence detection. Signal when PHOTO, LOOP1 and LOOP2 are activated, remains until either PHOTO, LOOP1 or LOOP2 is clear.		
	08	Presence detection. Signal when either LOOP1 or LOOP2 is activated, remains until either LOOP1 or LOOP2 is clear.		
	09	Direction sensing. Signal when first LOOP1 and then LOOP2 are activated. The signal remains until LOOP2 is clear.		
	10	Direction sensing. Signal when first LOOP1 and then PHOTO are activated. The signal remains until PHOTO is clear.		
	11	Direction sensing. Signal when first LOOP2 and then LOOP1 are activated. The signal remains until LOOP1 is clear.		
	12	Direction sensing. Signal when first LOOP2 and then PHOTO are activated. The signal remains until PHOTO is clear.		
	13	Direction sensing. Signal when first PHOTO and then LOOP1 are activated. The signal remains until LOOP1 is clear.		
	14	Direction sensing. Signal when first PHOTO and then LOOP2 are activated. The signal remains until LOOP2 is clear.		

Programmable output 4

Note that the display of the o-channels is determined by the setting in C707 and C710

No.	Name	Range	Factory	Setting
o400	Function of output 4	0 - 4	0	
	0	Disabled		
	1	Position indication/Movement/Warning. Signal as configured in o410 – o422		
	2	Presence detection/Direction sensing. Signal as configured in o491		
	3	Lock		
	4	Alarm output. Signal as configured in o430 – o442		
o410	Open position	0 - 2	0	
	0	Disabled		
	1	Constant signal		
	2*	Invalid selection for DB410 (Flashing signal)		
o411	Mid position	0 - 2	1	
	0	Disabled		
	1	Constant signal		
	2*	Invalid selection for DB410 (Flashing signal)		
o412	Closed position	0 - 2	1	
	0	Disabled		
	1	Constant signal		
	2*	Invalid selection for DB410 (Flashing signal)		
o413	Movement	0 - 7	0	
	0	Disabled		
	1	Constant signal in the opening movement		
	2	Constant signal in the closing movement		
	3	Constant signal in the opening and closing movement		
	4	No signal during movement, used in combination with o410, o411 and o412.		
	5*	Invalid selection for DB410 (Flashing signal in opening movement)		
	6*	Invalid selection for DB410 (Flashing signal in closing movement)		
	7*	Invalid selection for DB410 (Flashing signal in opening and closing movement)		
o414	Delayed switch-off Switch off after the specified time Used for example for lighting that is switched off a specified time after closing	000.0-600.0 seconds	000.0	
o420	Warning time before start	000.0-600.0 seconds	000.0	
o421	Warning function in combination with o420	1 - 8	2	
	1	Constant signal before automatic closing		
	2	Constant signal before park and automatic closing		
	3	Constant signal before close signal, park and automatic closing		
	4	Constant signal before all signals		
	5*	Invalid selection for DB410 (Flashing signal before automatic closing)		
	6*	Invalid selection for DB410 (Flashing signal before park and automatic closing)		
	7*	Invalid selection for DB410 (Flashing signal before close signal, park and automatic closing)		
	8*	Invalid selection for DB410 (Flashing signal before all signals)		

* WARNING! This setting is possible, but NOT permitted! Selecting it means that the relay output will cease to function. The channel selection for flashing function may be used only together with DB407.

No.	Name	Range	Factory	Setting
o422	Function during warning time	1 - 2	1	
	1	Output signal disabled during warning in other output		
	2	Output signal as configured in o410-o413		
o423	Flashing frequency	0.1-2.0 seconds	0.5	
o430*	Alarm if there is an error as configured in o431-o442. The alarm is activated for at least the time set in this channel.	000.0-600.0 seconds	000.0	
o431*	Alarm for faulty safety edge. Time as in o430.	0 - 1	0	
	0	Constant signal		
	1	Active		
o432*	Alarm for critical error message in display	0-1	0	
	0	Constant signal		
	1	Active		
o433*	Alarm if stop circuit interrupted	0 - 1	0	
	0	Disabled		
	1	Constant signal		
o434*	Alarm if door open	0 - 1	0	
	0	Disabled		
	1	Constant signal		
o435*	Alarm if door is in mid position	0 - 1	0	
	0	Disabled		
	1	Constant signal		
o436*	Alarm if door is in closed position	0 - 1	0	
	0	Disabled		
	1	Constant signal		
o437*	Alarm if vehicle loop 1 is activated	0 - 1	0	
	0	Disabled		
	1	Constant signal		
o438*	Alarm if vehicle loop 2 is activated	0 - 1	0	
	0	Disabled		
	1	Constant signal		
o439*	Alarm if photocell interrupted	0 - 1	0	
	0	Disabled		
	1	Constant signal		
o442*	Alarm for uncritical error message in display. E008, E015, E028, E046, E047, E048, E201, E202, E206, E207, E931, E932	0-1	0	
	0	Disabled		
	1	Constant signal		
o483	Inversion of contact function for output	1 - 2	1	
	1	Normally open, NO		
	2	Normally closed, NC		

* = Only when o400 is set to 4.

No.	Name	Range	Factory	Setting
o491	Function when LOOP2, LOOP2 or PHOTO activated	01 - 14	01	
	01	Presence detection Signal when LOOP1 is activated, remains until LOOP1 is clear.		
	02	Presence detection Signal when LOOP2 is activated, remains until LOOP2 is clear.		
	03	Presence detection. Signal when both LOOP1 and LOOP2 are activated, remains until either LOOP1 or LOOP2 is clear.		
	04	Presence detection. Signal when PHOTO is activated, remains until PHOTO is clear.		
	05	Presence detection. Signal when PHOTO and LOOP1 are activated, remains until either PHOTO or LOOP1 is clear.		
	06	Presence detection. Signal when PHOTO and LOOP2 are activated, remains until either PHOTO or LOOP2 is clear.		
	07	Presence detection. Signal when PHOTO, LOOP1 and LOOP2 are activated, remains until either PHOTO, LOOP1 or LOOP2 is clear.		
	08	Presence detection. Signal when either LOOP1 or LOOP2 is activated, remains until either LOOP1 or LOOP2 is clear.		
	09	Direction sensing. Signal when first LOOP1 and then LOOP2 are activated. The signal remains until LOOP2 is clear.		
	10	Direction sensing. Signal when first LOOP1 and then PHOTO are activated. The signal remains until PHOTO is clear.		
	11	Direction sensing. Signal when first LOOP2 and then LOOP1 are activated. The signal remains until LOOP1 is clear.		
	12	Direction sensing. Signal when first LOOP2 and then PHOTO are activated. The signal remains until PHOTO is clear.		
	13	Direction sensing. Signal when first PHOTO and then LOOP1 are activated. The signal remains until LOOP1 is clear.		
	14	Direction sensing. Signal when first PHOTO and then LOOP2 are activated. The signal remains until LOOP2 is clear.		

Programmable output 5

Note that the display of the o-channels is determined by the setting in C707 and C710

No.	Name	Range	Factory	Setting
o500	Function of output 1	0 - 4	0	
	0	Disabled		
	1	Position indication/Movement/Warning. Signal as configured in o510 – o522		
	2	Presence detection/Direction sensing. Signal as configured in o591		
	3	Lock		
	4	Alarm output. Signal as configured in o530 – o542		
o510	Open position	0 - 1	0	
	0	Disabled		
	1	Constant signal		
o511	Mid position	0 - 1	0	
	0	Disabled		
	1	Constant signal		
o512	Closed position	0 - 1	0	
	0	Disabled		
	1	Constant signal		
o513	Movement	0 - 4	4	
	0	Disabled		
	1	Constant signal in the opening movement		
	2	Constant signal in the closing movement		
	3	Constant signal in the opening and closing movement		
	4	No signal during movement, used in combination with o510, o511 and o512.		
o514	Delayed switch-off Switch off after the specified time Used for example for lighting that is switched off a specified time after closing	000.0-600.0 seconds	000.0	
o520	Warning time before start	000.0-600.0 seconds	000.0	
o521	Warning function in combination with o520	1-4	2	
	1	Constant signal before automatic closing		
	2	Constant signal before park and automatic closing		
	3	Constant signal before close signal, park and automatic closing		
	4	Constant signal before all signals		
o522	Function during warning time	1 - 2	1	
	1	Output signal disabled during warning in other output		
	2	Output signal as configured in o510-o513		

No.	Name	Range	Factory	Setting
o530*	Alarm if there is an error as configured in o531-o539. The alarm is activated for at least the time set in this channel.	000.0-600.0 seconds	000.0	
o531*	Alarm for faulty safety edge. Time as in o530.	0-1	0	
	0	Disabled		
	1	Constant signal		
o532*	Alarm for critical error message in display	0-1	0	
	0	Disabled		
	1	Constant signal		
o533*	Alarm if stop circuit interrupted	0 - 1	0	
	0	Disabled		
	1	Constant signal		
o534*	Alarm if door open	0 - 1	0	
	0	Disabled		
	1	Constant signal		
o535*	Alarm if door is in mid position	0 - 1	0	
	0	Disabled		
	1	Constant signal		
o536*	Alarm if door is in closed position	0 - 1	0	
	0	Disabled		
	1	Constant signal		
o537*	Alarm if vehicle loop 1 is activated	0 - 1	0	
	0	Disabled		
	1	Constant signal		
o538*	Alarm if vehicle loop 2 is activated	0 - 1	0	
	0	Disabled		
	1	Constant signal		
o539*	Alarm if photocell interrupted	0 - 1	0	
	0	Disabled		
	1	Constant signal		
o542*	Alarm for uncritical error message in display. E008, E015, E028, E046, E047, E048, E201, E202, E206, E207, E931, E932	0-1	0	
	0	Disabled		
	1	Constant signal		
o583	Inversion of contact function for output	1 - 2	1	
	1	Normally open, NO		
	2	Normally closed, NC		

* = Only when o500 is set to 4.

No.	Name	Range	Factory	Setting
o591	Function when LOOP2, LOOP2 or PHOTO activated	01 - 14	01	
	01	Presence detection. Signal when LOOP1 is activated, remains until LOOP1 is clear.		
	02	Presence detection. Signal when LOOP2 is activated, remains until LOOP2 is clear.		
	03	Presence detection. Signal when both LOOP1 and LOOP2 are activated, remains until either LOOP1 or LOOP2 is clear.		
	04	Presence detection. Signal when PHOTO is activated, remains until PHOTO is clear.		
	05	Presence detection. Signal when PHOTO and LOOP1 are activated, remains until either PHOTO or LOOP1 is clear.		
	06	Presence detection. Signal when PHOTO and LOOP2 are activated, remains until either PHOTO or LOOP2 is clear.		
	07	Presence detection. Signal when PHOTO, LOOP1 and LOOP2 are activated, remains until either PHOTO, LOOP1 or LOOP2 is clear.		
	08	Presence detection. Signal when either LOOP1 or LOOP2 is activated, remains until either LOOP1 or LOOP2 is clear.		
	09	Direction sensing. Signal when first LOOP1 and then LOOP2 are activated. The signal remains until LOOP2 is clear.		
	10	Direction sensing. Signal when first LOOP1 and then PHOTO are activated. The signal remains until PHOTO is clear.		
	11	Direction sensing. Signal when first LOOP2 and then LOOP1 are activated. The signal remains until LOOP1 is clear.		
	12	Direction sensing. Signal when first LOOP2 and then PHOTO are activated. The signal remains until PHOTO is clear.		
	13	Direction sensing. Signal when first PHOTO and then LOOP1 are activated. The signal remains until LOOP1 is clear.		
	14	Direction sensing. Signal when first PHOTO and then LOOP2 are activated. The signal remains until LOOP2 is clear.		

Programmable output 6

Note that the display of the o-channels is determined by the setting in C707 and C710

No.	Name	Range	Factory	Setting
o600	Function of output 1	0 - 4	0	
	0	Disabled		
	1	Position indication/Movement/Warning. Signal as configured in o610 – o622		
	2	Presence detection/Direction sensing. Signal as configured in o691		
	3	Lock		
	4	Alarm output. Signal as configured in o630 – o642		
o610	Open position	0 - 1	0	
	0	Disabled		
	1	Constant signal		
o611	Mid position	0 - 1	0	
	0	Disabled		
	1	Constant signal		
o612	Closed position	0 - 1	0	
	0	Disabled		
	1	Constant signal.		
o613	Movement	0 - 4	4	
	0	Disabled		
	1	Constant signal in the opening movement		
	2	Constant signal in the closing movement		
	3	Constant signal in the opening and closing movement		
	4	No signal during movement, used in combination with o610, o611 and o612.		
o614	Delayed switch-off Switch off after the specified time Used for example for lighting that is switched off a specified time after closing	000.0-600.0 seconds	000.0	
o620	Warning time before start	000.0-600.0 seconds	000.0	
o621	Warning function in combination with o620	1-4	2	
	1	Constant signal before automatic closing		
	2	Constant signal before park and automatic closing		
	3	Constant signal before close signal, park and automatic closing		
	4	Constant signal before all signals		
o622	Function during warning time	1 - 2	1	
	1	Output signal disabled during warning in other output		
	2	Output signal as configured in o610-o613		

No.	Name	Range	Factory	Setting
o630*	Alarm if there is an error as configured in o631-o642. The alarm is activated for at least the time set in this channel.	000.0-600.0 seconds	000.0	
o631*	Alarm for faulty safety edge. Time as in o630.	0-1	0	
	0	Disabled		
	1	Constant signal		
o632*	Alarm for critical error message in display	0-1	0	
	0	Disabled		
	1	Constant signal		
o633*	Alarm if stop circuit interrupted	0 - 1	0	
	0	Disabled		
	1	Constant signal		
o634*	Alarm if door open	0 - 1	0	
	0	Disabled		
	1	Constant signal		
o635*	Alarm if door is in mid position	0 - 1	0	
	0	Disabled		
	1	Constant signal		
o636*	Alarm if door is in closed position	0 - 1	0	
	0	Disabled		
	1	Constant signal		
o637*	Alarm if vehicle loop 1 is activated	0 - 1	0	
	0	Disabled		
	1	Constant signal		
o638*	Alarm if vehicle loop 2 is activated	0 - 1	0	
	0	Disabled		
	1	Constant signal		
o639*	Alarm if photocell interrupted	0 - 1	0	
	0	Disabled		
	1	Constant signal		
o642*	Alarm for uncritical error message in display. E008, E015, E028, E046, E047, E048, E201, E202, E206, E207, E931, E932	0-1	0	
	0	Disabled		
	1	Constant signal		
o683	Inversion of contact function for output	1 - 2	1	
	1	Normally open, NO		
	2	Normally closed, NC		

* = Only when o600 is set to 4.

No.	Name	Range	Factory	Setting
o691	Function when LOOP2, LOOP2 or PHOTO activated	01 - 14	01	
	01	Presence detection. Signal when LOOP1 is activated, remains until LOOP1 is clear.		
	02	Presence detection. Signal when LOOP2 is activated, remains until LOOP2 is clear.		
	03	Presence detection. Signal when both LOOP1 and LOOP2 are activated, remains until either LOOP1 or LOOP2 is clear.		
	04	Presence detection. Signal when PHOTO is activated, remains until PHOTO is clear.		
	05	Presence detection. Signal when PHOTO and LOOP1 are activated, remains until either PHOTO or LOOP1 is clear.		
	06	Presence detection. Signal when PHOTO and LOOP2 are activated, remains until either PHOTO or LOOP2 is clear.		
	07	Presence detection. Signal when PHOTO, LOOP1 and LOOP2 are activated, remains until either PHOTO, LOOP1 or LOOP2 is clear.		
	08	Presence detection. Signal when either LOOP1 or LOOP2 is activated, remains until either LOOP1 or LOOP2 is clear.		
	09	Direction sensing. Signal when first LOOP1 and then LOOP2 are activated. The signal remains until LOOP2 is clear.		
	10	Direction sensing. Signal when first LOOP1 and then PHOTO are activated. The signal remains until PHOTO is clear.		
	11	Direction sensing. Signal when first LOOP2 and then LOOP1 are activated. The signal remains until LOOP1 is clear.		
	12	Direction sensing. Signal when first LOOP2 and then PHOTO are activated. The signal remains until PHOTO is clear.		
	13	Direction sensing. Signal when first PHOTO and then LOOP1 are activated. The signal remains until LOOP1 is clear.		
	14	Direction sensing. Signal when first PHOTO and then LOOP2 are activated. The signal remains until LOOP2 is clear.		

- Programmable inputs, P channels

- Programmable input 1

No.	Name	Range	Factory	Setting
P100	Programmable input 1	0-1	1	
	0	Disabled		
	1	Enabled		
P160	Control function	0-5	1	
	0	Disabled		
	1	Open		
	2	Close		
	3	Stop		
	4	Open/Close		
	5	Open/Stop/Close		
▲ P161	Type of control signal when activated	1 - 2	1	
	1	Pulse (hold-to-run mode not possible)		
	2	Signal for as long as the input is activated		
P162	Half operation	1 - 3	3	
	1	Motor 1		
	2	Motor 2		
	3	Motors 1 and 2		
P163	Limited opening	0 - 1	0	
	0	Disabled		
	1	Opening according to set time in channel L216/L226 or number of degrees in L116/L126 if encoder is used.		
P170	Motor lock	0 - 1	0	
	0	Disabled		
	1	The gate cannot be operated without a signal at programmable input 1. If the signal disappears ongoing movement stops.		
P175	Opening via input after activation during set time, input will not open the gate until it has been activated for the set time.	0.0-9.9 seconds	0.0	
P180	Park	0 - 2	2	
	0	Disabled		
	1	Automatic closing disabled after the input is activated, reset by another control signal		
	2	Automatic closing disabled by a constant signal.		
P190	Interlock opening	0 - 1	0	
	0	Disabled		
	1	Opens the local door if P160 is set to open, and passes the signal on to the remote door		
P196	Blocking disabled for local and remote doors. Works only with a constant signal.	0 - 1	0	
	0	Disabled, function according to channel C614		
	1	Blocking disabled		
P198	Automatic closing switched off for remote door. Works only if there is a constant signal	0 - 1	0	
	0	Disabled, function according to channel C500		
	1	Automatic closing switched off		

Programmable input 2

No.	Name	Range	Factory	Setting
P200	Programmable input 2	0-1	1	
	0	Disabled		
	1	Enabled		
P260	Control function	0-5	2	
	0	Disabled		
	1	Open		
	2	Close		
	3	Stop		
	4	Open/Close		
	5	Open/Stop/Close		
▲ P261	Type of control signal when activated	1 - 2	1	
	1	Pulse (hold-to-run mode not possible)		
	2	Signal for as long as the input is activated		
P262	Half operation	1 - 3	3	
	1	Motor 1		
	2	Motor 2		
	3	Motors 1 and 2		
P263	Limited opening	0 - 1	0	
	0	Disabled		
	1	Opening according to set time in channel L216/L226 or number of degrees in L116/L126 if encoder is used.		
P270	Motor lock	0 - 1	0	
	0	Disabled		
	1	The gate cannot be operated without a signal at programmable input 2. If the signal disappears ongoing movement stops.		
P275	Opening via input after activation during set time, input will not open the gate until it has been activated for the set time.	0.0-9.9 seconds	0.0	
P280	Park	0 - 2	0	
	0	Disabled		
	1	Automatic closing disabled after the input is activated, reset by another control signal		
	2	Automatic closing disabled by a constant signal		
P290	Interlock opening	0 - 1	0	
	0	Disabled		
	1	Opens the local door if P260 is set to open, and passes the signal on to the remote door		
P296	Blocking disabled for local and remote doors. Works only with a constant signal.	0 - 1	0	
	0	Disabled, function according to channel C614		
	1	Blocking disabled		
P298	Automatic closing switched off for remote door. Works only if there is a constant signal	0 - 1	0	
	0	Disabled, function according to channel C500		
	1	Automatic closing switched off		

Programmable input 3

No.	Name	Range	Factory	Setting
P300	Programmable input 3	0-1	1	
	0	Disabled		
	1	Enabled		
P360	Control function	0-5	1	
	0	Disabled		
	1	Open		
	2	Close		
	3	Stop		
	4	Open/Close		
	5	Open/Stop/Close		
▲ P361	Type of control signal when activated	1 - 2	2	
	1	Pulse (hold-to-run mode not possible)		
	2	Signal for as long as the input is activated		
P362	Half operation	1 - 3	3	
	1	Motor 1		
	2	Motor 2		
	3	Motors 1 and 2		
P363	Limited opening	0 - 1	0	
	0	Disabled		
	1	Opening according to set time in channel L216/L226 or number of degrees in L116/L126 if encoder is used.		
P370	Motor lock	0 - 1	0	
	0	Disabled		
	1	The gate cannot be operated without a signal at programmable input 3. If the signal disappears ongoing movement stops.		
P375	Opening via input after activation during set time, input will not open the gate until it has been activated for the set time.	0.0-9.9 seconds	0.0	
P380	Park	0 - 2	0	
	0	Disabled		
	1	Automatic closing disabled after the input is activated, reset by another control signal		
	2	Automatic closing disabled by a constant signal.		
P390	Interlock opening	0 - 1	0	
	0	Disabled		
	1	Opens the local door if P360 is set to open, and passes the signal on to the remote door		
P396	Blocking disabled for local and remote doors. Works only with a constant signal.	0 - 1	0	
	0	Disabled, function according to channel C614		
	1	Blocking disabled		
P398	Automatic closing switched off for remote door. Works only if there is a constant signal	0 - 1	0	
	0	Disabled, function according to channel C500		
	1	Automatic closing switched off		

Programmable input 4

No.	Name	Range	Factory	Setting
P400	Programmable input 4	0-1	1	
	0	Disabled		
	1	Enabled		
P460	Control function	0-5	2	
	0	Disabled		
	1	Open		
	2	Close		
	3	Stop		
	4	Open/Close		
	5	Open/Stop/Close		
▲ P461	Type of control signal when activated	1 - 2	2	
	1	Pulse		
	2	Signal for as long as the input is activated		
P462	Half operation	1 - 3	3	
	1	Motor 1		
	2	Motor 2		
	3	Motors 1 and 2		
P463	Limited opening	0 - 1	0	
	0	Disabled		
	1	Opening according to set time in channel L216/L226 or number of degrees in L116/L126 if encoder is used.		
P470	Motor lock	0 - 1	0	
	0	Disabled		
	1	The gate cannot be operated without a signal at programmable input 4. If the signal disappears ongoing movement stops.		
P475	Opening via input after activation during set time, input will not open the gate until it has been activated for the set time.	0.0-9.9 seconds	0.0	
P480	Park	0 - 2	0	
	0	Disabled		
	1	Automatic closing disabled after the input is activated, reset by another control signal		
	2	Automatic closing disabled by a constant signal.		
P490	Interlock opening	0 - 1	0	
	0	Disabled		
	1	Opens the local door if P460 is set to open, and passes the signal on to the remote door		
P496	Blocking disabled for local and remote doors. Works only with a constant signal.	0 - 1	0	
	0	Disabled, function according to channel C614		
	1	Blocking disabled		
P498	Automatic closing switched off for remote door. Works only if there is a constant signal	0 - 1	0	
	0	Disabled, function according to channel C500		
	1	Automatic closing switched off		

Programmable input 5

No.	Name	Range	Factory	Setting
P500	Programmable input 6	0-1	1	
	0	Disabled		
	1	Activated (Only channels P560-P598 activated)		
	2	Battery operation, only together with frequency converter (Channels P560-P598 inactivated)		
P560	Control function	0-5	0	
	0	Disabled		
	1	Open		
	2	Close		
	3	Stop		
	4	Open/Close		
	5	Open/Stop/Close		
▲ P561	Type of control signal when activated	1 - 2	1	
	1	Pulse		
	2	Signal for as long as the input is activated		
P562	Half operation	1 - 3	3	
	1	Motor 1		
	2	Motor 2		
	3	Motors 1 and 2		
P563	Limited opening	0 - 1	0	
	0	Disabled		
	1	Opening according to set time in channel L216/L226 or number of degrees in L116/L126 if encoder is used.		
P570	Motor lock	0 - 1	0	
	0	Disabled		
	1	The gate cannot be operated without a signal at programmable input 5. If the signal disappears ongoing movement stops.		
P575	Opening via input after activation during set time, input will not open the gate until it has been activated for the set time.	0.0-9.9 seconds	0.0	
P580	Park	0 - 2	0	
	0	Disabled		
	1	Automatic closing disabled after the input is activated, reset by another control signal		
	2	Automatic closing disabled by a constant signal.		
P590	Interlock opening	0 - 1	0	
	0	Disabled		
	1	Opens the local door if P560 is set to open, and passes the signal on to the remote door		
P596	Blocking disabled for local and remote doors. Works only with a constant signal.	0 - 1	0	
	0	Disabled, function according to channel C614		
	1	Blocking disabled		
P598	Automatic closing switched off for remote door. Works only if there is a constant signal	0 - 1	0	
	0	Disabled, function according to channel C500		
	1	Automatic closing switched off		

Programmable input 6

No.	Name	Range	Factory	Setting
P600	Programmable input 6	0-1	1	
	0	Disabled		
	1	Activated (Only channels P660-P698 activated)		
	2	Safety input (Only channels P640-P643 activated)		
P640	Safety function when input is activated	0 – 3	1	
	0	Disabled		
	1	Reverse to fully open		
	2	Stop with automatic restart of automatic closing		
	3	Stop, wait for new control signal or time in C520 and thereafter automatic closing.		
P641	Safety during run-on time or disengagement angle in closing movement.	0-1	0	
	0	Disabled when both halves are in run-on or disengagement angle		
	1	Activated according to P640		
P642	Protection in opening movement	0-4	1	
	0	Disabled		
	1	Reverse to fully closed		
	2	Stop with automatic restart of automatic closing		
	3	Stop, wait for new control signal or time in C520 and then automatic closing.		
	4	Stop with restart of opening		
P643	Control of external protection connected to INP6	0-1	1	
	0	No check		
	1	Test of break in continuity for protection connected to INP6		
P660	Control function	0 - 5	0	
	0	Disabled		
	1	Open		
	2	Close		
	3	Stop		
	4	Open/Close		
	5	Open/Stop/Close		
▲ P661	Type of control signal when activated	1 - 2	1	
	1	Pulse		
	2	Signal for as long as the input is activated		
P662	Half operation	1 - 3	3	
	1	Motor 1		
	2	Motor 2		
	3	Motors 1 and 2		
P663	Limited opening	0 - 1	0	
	0	Disabled		
	1	Opening according to set time in channel L216/L226 or number of degrees in L116/L126 if encoder is used.		
P670	Motor lock	0 - 1	0	
	0	Disabled		
	1	The gate cannot be operated without a signal at programmable input 6. If the signal disappears ongoing movement stops.		

No.	Name	Range	Factory	Setting
P675	Opening via input after activation during set time, input will not open the gate until it has been activated for the set time.	0.0-9.9 seconds	0.0	
P680	Park	0 - 2	0	
	0	Disabled		
	1	Automatic closing disabled after the input is activated, reset by another control signal		
	2	Automatic closing disabled by a constant signal.		
P690	Interlock opening	0 - 1	0	
	0	Disabled		
	1	Opens the local door if P660 is set to open, and passes the signal on to the remote door		
P696	Blocking disabled for local and remote doors. Works only with a constant signal.	0 - 1	0	
	0	Disabled, function according to channel C614		
	1	Blocking disabled		
P698	Automatic closing switched off for remote door. Works only if there is a constant signal	0 - 1	0	
	0	Disabled, function according to channel C500		
	1	Automatic closing switched off		

- Radio DB411, r-channels
Programmable radio input 1

Note that the display of the r-channels is determined by the setting in C711

No.	Name	Range	Factory	Setting
r001	Readout of received radio input	0 - 4		
	0	No radio reception		
	1	Radio input 1 is receiving a radio signal		
	2	Radio input 2 is receiving a radio signal		
	3	Radio input 3 is receiving a radio signal		
	4	Radio input 4 is receiving a radio signal		
r160	Control function	0 - 5	0	
	0	Disabled		
	1	Open		
	2	Close		
	3	Stop		
	4	Open/close		
	5	Open/Stop/Close		
r162	Half operation	1 - 3	3	
	1	Motor 1		
	2	Motor 2		
	3	Motor 1 and Motor 2		
r163	Limited opening	0 - 1	0	
	0	Disabled		
	1	Opening according to set time in channel L216/L226 or number of degrees in L116/L126 if encoder is used.		
r170	Disable operation at radio input 1.	0 - 6	0	
	0	Disabled, normal operation. (Programmable input has no function for radio input 1)		
	1	Operate only if there is a signal at programmable input 1		
	2	Operate only if there is a signal at programmable input 2		
	3	Operate only if there is a signal at programmable input 3		
	4	Operate only if there is a signal at programmable input 4		
	5	Operate only if there is a signal at programmable input 5		
	6	Operate only if there is a signal at programmable input 6		
r180	Park	0 - 1	0	
	0	Disabled		
	1	Park without automatic closing. Reset by another control signal		
r190	Interlock opening	0 - 1	0	
	0	Disabled		
	1	Sends a normal open signal to the remote door		

Programmable wireless input 2

Note that the display of the r-channels is determined by the setting in C711

No.	Name	Range	Factory	Setting
r001	Readout of received wireless input	0 - 4		
	0	No radio reception		
	1	Radio input 1 is receiving a radio signal		
	2	Radio input 2 is receiving a radio signal		
	3	Radio input 3 is receiving a radio signal		
	4	Radio input 4 is receiving a radio signal		
r260	Control function	0 - 5	0	
	0	Disabled		
	1	Open		
	2	Close		
	3	Stop		
	4	Open/close		
	5	Open/Stop/Close		
r262	Half operation	1 - 3	3	
	1	Motor 1		
	2	Motor 2		
	3	Motor 1 and Motor 2		
r263	Limited opening	0 - 1	0	
	0	Disabled		
	1	Opening according to set time in channel L216/L226 or number of degrees in L116/L126 if encoder is used.		
r270	Disable operation at radio input 2.	0 - 6	0	
	0	Disabled, normal operation. (Programmable input has no function for radio input 2)		
	1	Operate only if there is a signal at programmable input 1		
	2	Operate only if there is a signal at programmable input 2		
	3	Operate only if there is a signal at programmable input 3		
	4	Operate only if there is a signal at programmable input 4		
	5	Operate only if there is a signal at programmable input 5		
	6	Operate only if there is a signal at programmable input 6		
r280	Park	0 - 1	0	
	0	Disabled		
	1	Park without automatic closing. Reset by another control signal		
r290	Interlock opening	0 - 1	0	
	0	Disabled		
	1	Sends a normal open signal to the remote door		

Programmable wireless input 3

Note that the display of the r-channels is determined by the setting in C711

No.	Name	Range	Factory	Setting
r001	Readout of received radio input	0 - 4	0	
	0	No radio reception		
	1	Radio input 1 is receiving a radio signal		
	2	Radio input 2 is receiving a radio signal		
	3	Radio input 3 is receiving a radio signal		
	4	Radio input 4 is receiving a radio signal		
r360	Control function	0 - 5	0	
	0	Disabled		
	1	Open		
	2	Close		
	3	Stop		
	4	Open/close		
	5	Open/Stop/Close		
r362	Half operation	1 - 3	3	
	1	Motor 1		
	2	Motor 2		
	3	Motor 1 and Motor 2		
r363	Limited opening	0 - 1	0	
	0	Disabled		
	1	Opening according to set time in channel L216/L226 or number of degrees in L116/L126 if encoder is used.		
r370	Disable operation at wireless input 3.	0 - 6	0	
	0	Disabled, normal operation. (Programmable input has no function for radio input 3)		
	1	Operate only if there is a signal at programmable input 1		
	2	Operate only if there is a signal at programmable input 2		
	3	Operate only if there is a signal at programmable input 3		
	4	Operate only if there is a signal at programmable input 4		
	5	Operate only if there is a signal at programmable input 5		
	6	Operate only if there is a signal at programmable input 6		
r380	Park	0 - 1	0	
	0	Disabled		
	1	Park without automatic closing. Reset by another control signal		
r390	Interlock opening	0 - 1	0	
	0	Disabled		
	1	Sends a normal open signal to the remote door		

Programmable wireless input 4

Note that the display of the r-channels is determined by the setting in C711

No.	Name	Range	Factory	Setting
r001	Readout of received wireless input	0 - 4		
	0	No radio reception		
	1	Radio input 1 is receiving a radio signal		
	2	Radio input 2 is receiving a radio signal		
	3	Radio input 3 is receiving a radio signal		
	4	Radio input 4 is receiving a radio signal		
r460	Control function	0 - 5	0	
	0	Disabled		
	1	Open		
	2	Close		
	3	Stop		
	4	Open/close		
	5	Open/Stop/Close		
r462	Half operation	1 - 3	3	
	1	Motor 1		
	2	Motor 2		
	3	Motor 1 and Motor 2		
r463	Limited opening	0 - 1	0	
	0	Disabled		
	1	Opening according to set time in channel L216/L226 or number of degrees in L116/L126 if encoder is used.		
r470	Disable operation at wireless input 4.	0 - 6	0	
	0	Disabled, normal operation. (Programmable input has no function for radio input 4)		
	1	Operate only if there is a signal at programmable input 1		
	2	Operate only if there is a signal at programmable input 2		
	3	Operate only if there is a signal at programmable input 3		
	4	Operate only if there is a signal at programmable input 4		
	5	Operate only if there is a signal at programmable input 5		
	6	Operate only if there is a signal at programmable input 6		
r480	Park	0 - 1	0	
	0	Disabled		
	1	Park without automatic closing. Reset by another control signal		
r490	Interlock opening	0 - 1	0	
	0	Disabled		
	1	Sends a normal open signal to the remote door		

Error messages in display and in the error code list in channel C903

Grey background means that the automatic control unit must be restarted (power off) in order to reset the error message.

Error code	Meaning	Possible cause
EP-1	Not an error code – indicates the type of EP105 in use	
EP-2	Not an error code – indicates the type of EP105 in use	
E000	No error, shown to acknowledge a change in the service channel.	
E003	Limited running time exceeded	Gears slipping? Check C403
E008	Momentary loss of 24 V	Mains failure, momentary 24 V short circuit.
E015	Momentary loss of 230 V	Has there been a power failure?
E016	Loss of mains power 230V	Has there been a power failure?
E017	Safety edge or load guard triggered five times in succession	Is something preventing the door reaching the closed position?
E020	Voltage too high in safety circuit	The voltage measured by the automatic control unit is too high.
E021	Voltage too low in safety circuit	Poor contact between connected stop buttons on terminals 7-12?
E025	Incorrect setting for personal protection, motor 1	Check C200 and C230, the load guard cannot be disabled with personal protection activated. Check C211, it cannot be longer than 0.06 seconds. C212 cannot be longer than 2 seconds. C493 cannot be longer than 0.20 seconds.
E026	Incorrect setting for personal protection, motor 2	Check C200 and C240, the load guard cannot be disabled with personal protection activated. Check C211, it cannot be longer than 0.06 seconds. C212 cannot be longer than 2 seconds. C493 cannot be longer than 0.20 seconds.
E028	Brake selected when C202 is set to 2, 4 or 5	Check that C495/C496 is set to 0.
E032	Limit switch L.O1 has lost its position	Is the limit switch cam bypassing the switch? Loose connection in switch?
E033	Limit switch L.C1 has lost its position	Is the limit switch cam bypassing the switch? Loose connection in switch?
E034	Limit switch L.O2 has lost its position	Is the limit switch cam bypassing the switch? Loose connection in switch?
E035	Limit switch L.C2 has lost its position	Is the limit switch cam bypassing the switch? Loose connection in switch?
E044	Hidden channels shown	
E046	Opening counter reset	
E047	Factory reset of all channels	
E048	Error code list reset	
E053	Unknown circuit board version	Contact FAAC Nordic AB
E116	No safety edge acknowledgement	Only applies to up-and-over control, fault in safety edge? Correct run-on time?
E141	SE.O2 is disabled when C104 is set to 3	Indication function of SE.O2 in channel C141
E201	Motor protection triggered for motor 1	Motor is taking more than 1.5x motor current. Motor is sluggish or stops. Faulty fuse? Phase failure in an incoming phase? Break in cable to motor or motor winding? Check the motor protection setting.
E202	Motor protection triggered for motor 2	
E203	Motor protection triggered four times in a row, control unit locked for 3 minutes	Is there an obstacle? Fault in electric motor? Check the configuration of channels C252, C253, C262, C263.
E204	Current through motor 1, which is switched off	
E205	Current through motor 2, which is switched off	

Error code	Meaning	Possible cause
E206	No current or low current in motor 1	The electric motor is running at less than half the motor protection setting. Check the motor protection setting. Phase failure in an incoming phase? Faulty fuse? Break in cable to electric motor? Voltage drop in stop circuit/limit switch circuit?
E207	No current or low current in motor 2	
E221	Start load too low, motor 1	Check that the motor is correctly connected.
E222	Start load too low, motor 2	Check that the motor is correctly connected.
E223	Normal power too low, motor 1	Check C230.
E224	Normal power too low, motor 2	Check C240.
E225	The load guard has been tripped three times in a row	Obstacle in the way? Mechanical fault preventing closing? Check the load guard settings.
E318	Error in loop 1	Are the loop and connectors electrically continuous?
E319	Error in loop 2	For more troubleshooting tips, see the instruction manual for the vehicle detector
E614	Communication error	Correct polarity in communication cables? Break in communication cable? Correct settings in both automatic control units? Is the external unit switched on?
E651	No response from frequency converter motor 1	Check the connection and the settings as described in Instruction Manual for DB409. Address must be set for the frequency converter.
E652	No response from frequency converter motor 2	Check the connection and the settings as described in Instruction Manual for DB409. Address must be set for the frequency converter.
E661	Incorrect value sent to frequency converter for motor 1	Contact FAAC Nordic AB
E662	Incorrect value sent to frequency converter for motor 2	Contact FAAC Nordic AB
E671	Incorrect response from frequency converter for motor 1	Contact FAAC Nordic AB
E672	Incorrect response from frequency converter for motor 2	Contact FAAC Nordic AB
E901	Extraneous voltage at safety edge input SE.C1	Contact FAAC Nordic AB.
E902	Extraneous voltage at safety edge input SE.C2	Contact FAAC Nordic AB.
E903	Extraneous voltage at safety edge input SE.O1	Contact FAAC Nordic AB.
E904	Extraneous voltage at limit switch input	Contact FAAC Nordic AB.
E905	Extraneous voltage in stop circuit	Contact FAAC Nordic AB.
E906	Extraneous voltage at safety edge input SE.O2	Contact FAAC Nordic AB.
E906	Extraneous voltage on limit switch L.O1	Contact FAAC Nordic AB.
E908	Extraneous voltage on limit switch L.O2	Contact FAAC Nordic AB.
E912	Incorrect checksum in flash memory	Contact FAAC Nordic AB.
E913	Memory error in RAM	Contact FAAC Nordic AB.
E914	Memory error in EEPROM	Contact FAAC Nordic AB.
E915	Incorrect EEPROM version	Contact FAAC Nordic AB.
E916	Internal test not completed in time	Contact FAAC Nordic AB.
E917	Incorrect order of execution	Contact FAAC Nordic AB.
E921	Contact for motor 1 activated before the previously activated contactor has been deactivated.	Contact FAAC Nordic AB.
E922	Contact for motor 2 activated before the previously activated contactor has been deactivated.	Contact FAAC Nordic AB.
E931	Stop at the same time as an open/close operation.	
E932	Open operation at the same time as a close operation.	

Error code	Meaning	Possible cause
E941	Motor 1 running in the wrong direction according to the encoder setting.	Check that channel L110 is set to the correct side. Check the motor is running in the right direction.
E942	Motor 2 running in the wrong direction according to the encoder setting.	Check that channel L120 is set to the correct side. Check the motor is running in the right direction.
E943	No movement encoder 1	Check connection to the encoder.
E944	No movement encoder 2	Check connection to the encoder.
E961	SE.C1 did not change to low during the external test.	Check that the safety edge is functional, if the safety edge is not functional, set channel C113 to 0.
E962	SE.C2 did not change to low during the external test.	Check that the safety edge is functional, if the safety edge is not functional, set channel C123 to 0.
E963	SE.O1 did not change to low during the external test.	Check that the safety edge is functional, if the safety edge is not functional, set channel C133 to 0.
E964	PHOTO did not change to low during the external test.	Check that the safety edge is functional, if the safety edge is not functional, set channel C343 to 0.
E965	INP6 did not change to low during the external test.	Check that INP6 is working, if no self-test in the photocell, set channel P643 to 0.
E966	SE.O2 did not change to low during the external test.	Check that the safety edge is functional, if the safety edge is not functional, set channel C143 to 0.
E971	SE.C1 did not change to high during the external test.	Check that the safety edge is functional, if the safety edge is not functional, set channel C113 to 0.
E972	SE.C2 did not change to high during the external test.	Check that the safety edge is functional, if the safety edge is not functional, set channel C123 to 0.
E973	SE.O1 did not change to high during the external test.	Check that the safety edge is functional, if the safety edge is not functional, set channel C133 to 0.
E976	SE.O2 did not change to high during the external test.	Check that the safety edge is functional, if the safety edge is not functional, set channel C143 to 0.

Messages in display and in the error code list in channel C903

Code	Meaning
n021	Safety function for the photocell activated while opening
n022	Safety function for the photocell activated while closing
n031	Safety function for vehicle loop 1 activated while opening
n032	Safety function for vehicle loop 1 activated while closing
n033	Safety function for vehicle loop 2 activated while opening
n034	Safety function for vehicle loop 2 activated while closing
n041	Safety function for safety edge SE.O1 activated while opening
n042	Safety function for safety edge SE.C1 activated while closing
n043	Safety function for safety edge SE.O2 activated while opening
n044	Safety function for safety edge SE.C2 activated while closing
n071	Reverse due to load guard for motor 1 while opening
n072	Reverse due to load guard for motor 1 while closing
n073	Reverse due to load guard for motor 2 while opening
n074	Reverse due to load guard for motor 2 while closing

Troubleshooting

At each service, please check all the functions described in the relevant section on commissioning.

Problem	Possible cause, tip
Error message in the display (Ennn)	See the section above on error messages.
The door reverses and the red LEDs M1/M2 start flashing.	Is the load guard correctly installed? Has the correct supply voltage been set? Mechanical fault? Does the door move easily when decoupled?
Are the red LEDs SE.C1, SE.C2, SE.O1 or SE.O2 on or flashing?	Check the channels for the safety edge value. Is the impedance correct? Adjust the safety edge switch if necessary? Are all the safety edge units in use? Are any of the limit switch LEDs on? The safety edge will not work unless the limit switches are connected at the time the power is switched on. Is the stop LED on? The safety edge will not work unless the stop circuit is uninterrupted at the time the power is switched on.
The door will not open or close.	Are all the green LEDs that should be lit on? Have unused stop inputs been jumpered? Are any of the LEDs INP1-INP6 on? They should not usually be on (unless the system is parked at certain times). The limit switch LEDs must light up before the door can be operated. Example: L.O1 is on = motor 1 can start. The limit switches are connected in series with the stop circuit. Fault/interruption in the wicket door contact or other contact in the stop circuit. Check that the warning is configured. Check that the block is configured.
The door will not close but it will open.	The PHOTO LED should be on. Are any safety edge indications on? They should normally be off. Suspect an incorrect connection to the safety edge. Alternatively, an adjustment may be necessary. Check the channel for pulse operation.
No automatic closing.	Suspect an interruption somewhere in the stop circuit. Wicket door contact? Stop button? Check the setting for restart after stopping.
The display and LEDs do not switch on	Are all supply phases present? Possibly a short circuit to earth in a low current connection. Switch off at the main switch for 1 minute and remove all jackable terminals. Switch on the power again with the jackable terminals disconnected.
You will need to hold down the run button to operate.	Check that the automatic control unit is in pulse mode. Is the PHOTO LED on? Are any of the safety edge LEDs on? Is LOOP1 or LOOP2 lit? These should only be on if a vehicle is over the loop.
Does the door inexplicably close "by itself"? (without an error message or alarm LEDs)	Try to operate the door again, opening and closing. Also check C020 for the most recent stop cause. Cross-check the number with the channel reference to find out what stopped the door.

• Resetting/replacing tripped fuses

If the fuse protecting the power supply to the automatic control unit trips, FAAC Nordic AB recommends following these steps to reset/replace it.

- Switch off the main switch to the automatic control unit.
- Decouple the drive unit.
- Reset or replace the fuse.
- Switch on the main switch to the automatic control unit.
- Check that none of the drive units start before receiving the control signal.
- Check that the drive units can be started and stopped from the control buttons.
- If the drive unit cannot be stopped, contact FAAC Nordic AB.



FAAC