

## OVERALL DIMENSIONS

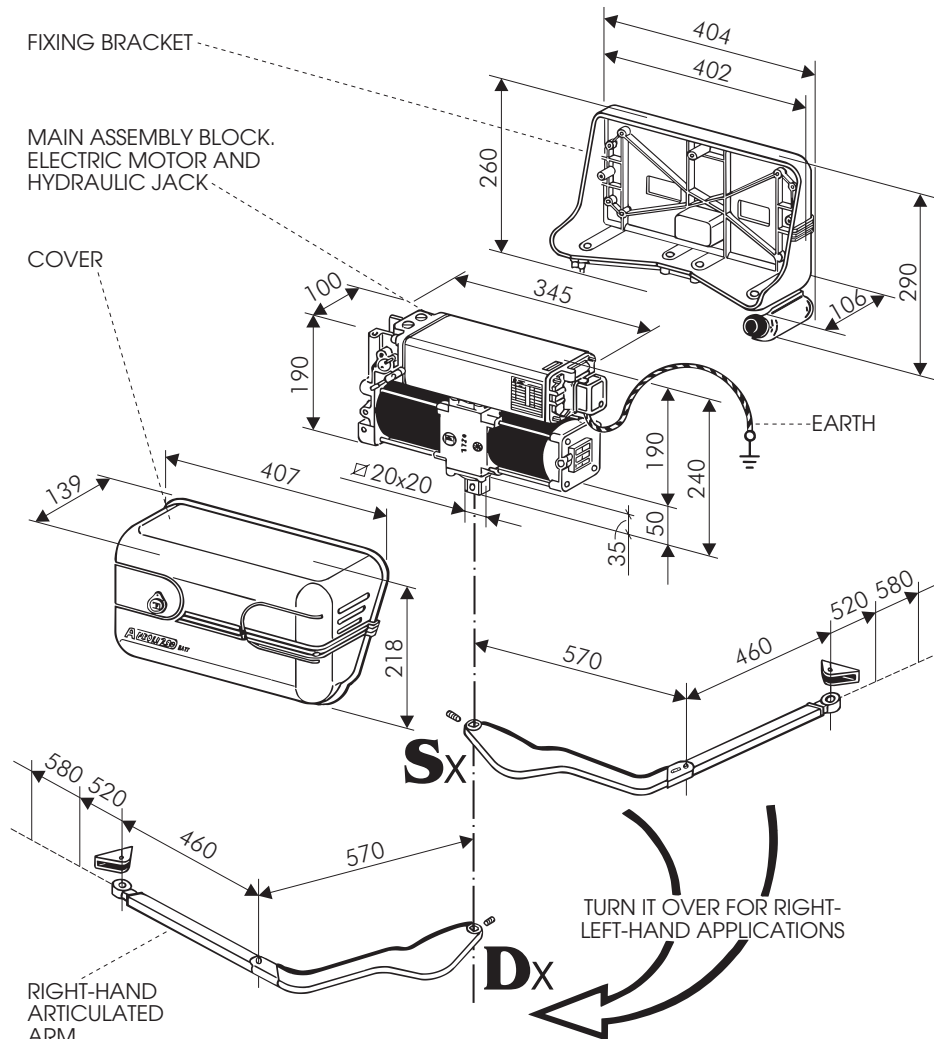

"APROLI 280 BATT" is a new oil-hydraulic gate operator designed for swinging gates hinged to large pillars. By removing the cover it is possible to see the jack, the oil reservoir above it and the valve block that connects the two parts into one single assembly. The valve block incorporates the main hydraulic features of the unit, ie. manual override by unscrewing the release valve in events like power failure, access to this valve is made easy through a suitably designed hinged door in the cover; air bleeding screw to facilitate oil flowing in the system; adjustable open and close safety pressure valves to control the amount of force developed by the operator and ensure total anti-crush operations.

In the valve block there is also a double by-pass valve that holds the gates safely open or closed, ie. hydraulically locked in either positions, when the motor stops. On starting the motor, oil is allowed to flow free and the gates can be operated as pre-set. The electric motor and the lobe designed pump are in an oil bath inside the oil reservoir, the external end cap of which is fitted with the electrical connections. It is inside the jack where movements are hydraulically transmitted: the shaft has a toothed central part that can mesh a rack system and can rotate 205°; shaft rotation is by oil pressure applied to either side of the rack by means of two pistons. The shaft has a square indented end part to which the articulated arm can be fitted. This is made of pressure cast, heat treated aluminium and consists of two sections hinged together; the gate fitting section is adjustable and has a suitably designed shoe for gate fixing.

The whole operator is weatherproof and made of shock resistant materials. Pressure cast aluminium has been used to produce the valve block, the main assembly block, the jack central casting and the fixing bracket. This one is factory machined to provide ready made holes for fixing and cable entry. The extremely precise movements of the parts inside the jack are guaranteed by treated, hardened steel which has been used to produce the rack, the shaft and the cylinder liners, which are very finely polished to provide a smooth finish. Sealing component parts such as oil rings and seals are also top quality, and the screws are galvanized. The cover is made of plastic to avoid extra weight on the operator; it is not fragile, tough and made of highly shock resistant materials. All the parts have a new, advanced design; the corners are rounded and the shape curved not only to improve aesthetic but also for safety reasons to prevent people from being injured during handling or normal use of the operator. On request, "APROLI 280 BATT" can be supplied with two flow regulators to be factory incorporated in the oil circuit to ensure constant shaft rotation speed rate in both gate travel directions. Two different opening speed rate options can be achieved through the hydraulic pump. Among the other most relevant features are the incorporated, adjustable gate stop in open gate position and the earth wire with connection facility.

## TECHNICAL SPECIFICATIONS

### Hydraulic Pump

Pump flow rate - P3	0.85 l/min.
Average working pressure	1 MPa (10 bars)
Max. pump pressure	3 MPa (30 bars)
Working temperature	- 20°C + 80°C
Opening time	23 s
Rated torque	196.2 Nm
Shaft rotation angle	max. 205°
Hydraulic oil	A 15 FADINI by AGIP
Static weight of operator	11 Kg
Max. weight of the gate	100 Kg
Protection standards	IP 555

### Electric motor

Power output	0.18 KW (0.25 HP)
Supply voltage	230 V
Frequency	50 Hz
Absorbed power	250 W
Absorbed current	1.2 A
Capacitor	12.5 µF
Motor rotation speed	1'350 r.p.m.
Intermittent service	S 3

Duty cycle 23 s Opening - 30 s Stop - 23 s Closing  
 Time of one complete cycle 76 s  
 No. of complete cycles Opening-Stop-Closing 47/h  
 137'000 cycles a year, 8 hours' service a day



EUROPEAN MARK CERTIFYING CONFORMITY TO THE ESSENTIAL REQUIREMENTS OF THE STANDARDS 98/37 EC



**FADINI**  
the gate opener  
Made in Italy



**meccanica FADINI**

Drwg. No. **1997**

**TECHNICAL SPECIFICATION TABLE**

**OIL-HYDRAULIC GATE OPERATOR SUITABLE FOR GATE POSTS/PILLARS OF SIGNIFICANT DIMENSIONS**